

1

PENDANT
PLUSMINUS
FLOOR & TABLE

2

CEILING
WALL
OUTDOOR



VIBIA

Better Spaces, Better Lives

Vibia exists to create beautiful **atmospheres** that enhance **wellbeing**.

We put **people at the centre** of everything we do; we aim to improve lives by helping professionals create better spaces for everyone to enjoy. This purpose is **shared across the entire space-design ecosystem**.



Shaping Atmospheres

We aim to lead a new approach to lighting focused on **people's emotions**, elevating interior design as a fundamental discipline for the cultivation of **wellbeing**.

We propose a new approach to designing **emotional atmospheres** based on the creation of specific **scenes** according to the use of a space over time, integrating dynamic light and advanced **control system** design. To support this, we offer a holistic product portfolio that provides a unique blend of lighting effects.

Relaxation



Activation



Concentration



Socialisation

Elevating Interior Design



Interior design is fundamental to the cultivation of **wellbeing**.



The designer's job is to create beautiful spaces that **generate positive emotions**. This begins with an understanding of how the human brain perceives sensory cues and the influence they have on our emotional response to a space.

The inter-relationship between the physical and spatial elements, the texture, form and composition of objects, the interior design, and the light, all depend on the specific atmosphere we want to achieve.

Vibia Portfolio: A Holistic Approach



Creating scenes of wellbeing through a **unique blend of lighting effects**



Diffuse



Indirect



Direct

We combine different lighting typologies with different levels of density, experimenting with a synthesis of **diffuse**, **indirect** and **direct** light to create the perfect ambience at any time of day.

Creating scenes of wellbeing with dynamic light

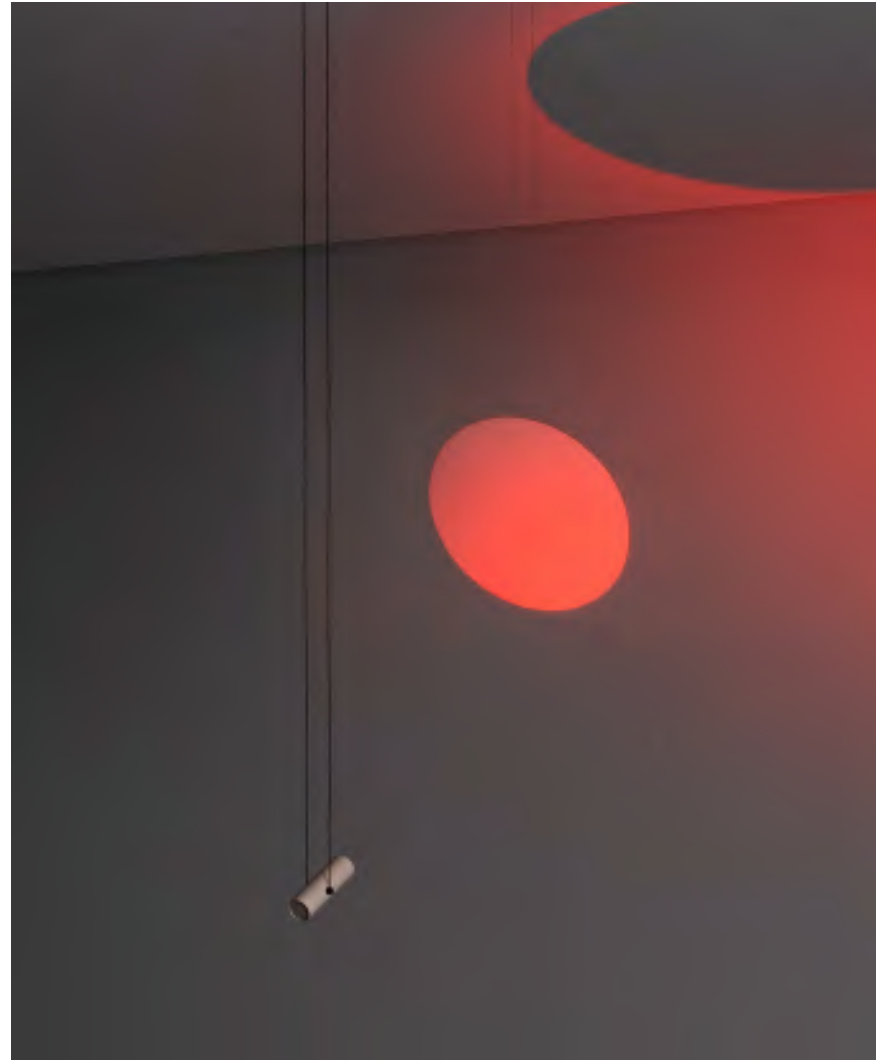

Dynamic light allows professionals to play with **subtle degrees of intensity and colour** to recreate an ambience for every scene within a lighting project.

Comfortable Environments

Vibia's spot accent, downlight and general lighting luminaires include the option of tunable white. Tunable lighting allows for comprehensive colour temperature and intensity regulation depending on the desired atmosphere for every scene. Combining tunable white lights with diffuse and indirect lighting effects allows you to design the perfect scene for every moment or use.

Chromatica Colours of Light

Natural light is never mono-tonal. Vibia's approach to the use of coloured light and gradients is to create beautiful atmospheres that are as natural and subtle as possible.

Static White

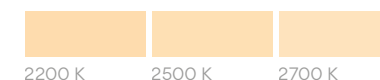

2200 K 2500 K 2700 K

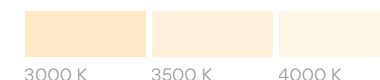

3000 K 3500 K 4000 K

Tunable White



1800 K 4000 K

Dim-To-Warm









1800 K 3000 K

Tunable Red



Red 2700 K

Colour Moods

-  **Still** - A pale and thin green light, inspired by the very first rays of morning sun
-  **Vivid** - A vibrating blue with a hint of pale yellow for a feeling of liveliness
-  **Delicate** - A warm and glowing orange-yellow hue, reminiscent of afternoon sun spilling through the window
-  **Cozy** - Bringing a glowing warmth, this orange-red hue contains darker, moodier undertones
-  **Intense** - A powerful and bold red. Not just a striking colour, but deep and nuanced
-  **Illusive** - An alluring and intriguing blue light that lends an energised, almost magical feel to a space

Sustainable Development

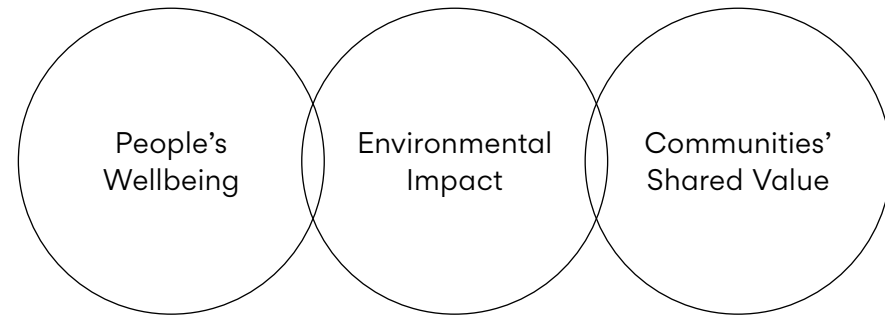

By creating better spaces we contribute to individual wellbeing, minimising our environmental impact on the planet and generating shared value across all our communities.



People's Wellbeing

Atmospheres of Wellbeing

We aim to introduce a new approach to lighting based on the **creation of atmospheres** that foster wellness and enrich people's lives.

Decoding Emotion

This starts with an understanding of how the human brain perceives sensory cues, decoding and maximising the **emotional impact** of a space.

Exploring Space Usage

We explore how individuals will **use a space** and design adaptable, hybrid scenes to accommodate their needs over time.

Dissemination of Knowledge

We contribute to the **elevation of interior design** as fundamental to the cultivation of wellbeing and to the dissemination of knowledge in the creation of atmospheres of wellbeing.

Minimising our Environmental Impact

Eco Design and Circularity

We are committed to design that lasts, minimising the amount of material and maximising the use of natural, recycled and recyclable materials. Reusability, sustainable packaging, installation, replaceability and disassembly are essential elements of our designs. This approach significantly reduces waste generation and supports the principles of a **circular economy**.

Decarbonisation

Our decarbonisation strategy focuses on **reducing our carbon footprint** by setting emission targets, minimising travel impact **through digitalisation** across the customer journey, and prioritising the **use of renewable energy**.

Energy Saving

Our environmental commitment involves **reducing energy consumption** by integrating energy-efficient components, controls, and systems that enhance lighting efficiency and quality.



Shared Value with Our Communities

Professional Space Design Community

Vibia fosters collaboration and co-creation within the space-design ecosystem, providing both digital and physical support services to ensure a **seamless customer journey**.

Vibia: The Place to Be

Our team of employees and collaborators comprises experts with diverse industry knowledge, fostering an inclusive, diverse, and **collaborative culture**.

Responsible Ecosystem

Our approach to responsible business practices includes corporate compliance, adherence to sustainability standards, recognitions in Environmental, Social, and Governance (ESG) criteria, and partnerships with **ESG-compliant suppliers**.

Social Commitment

We actively engage with local communities, promoting **social responsibility**, providing **education** and professional training opportunities, and **creating better spaces** for everyone to enjoy.

Volume

1

| | |
|---------------------|-----|
| Pendant | 1 |
| Plusminus | 271 |
| Floor & Table | 355 |
| Lighting Typologies | 486 |
| Support Portfolio | 490 |
| Item index | 492 |
| Acknowledgements | 495 |

Volume

2

| | |
|---------------------|-----|
| Ceiling | 1 |
| Wall | 209 |
| Outdoor | 359 |
| Lighting Typologies | 472 |
| Support Portfolio | 476 |
| Item index | 478 |
| Acknowledgements | 481 |

Collections

Africa

Floor & Table
Vol1 356

Algorithm Free

Pendant
Vol1 200

Algorithm Grid

Pendant
Vol1 206

Alpha

Wall
Vol2 316

Array

Pendant
Vol1 2

Balance

Floor & Table
Vol1 400

Bamboo

Outdoor
Vol2 414

Bigger

Pendant
Vol1 176
Ceiling
Vol2 202

Bind

Pendant
Vol1 240
Ceiling
Vol2 128

Bind Solo

Ceiling
Vol2 148

Break

Outdoor
Vol2 430

Break Plus

Outdoor
Vol2 435

Brisa

Outdoor
Vol2 402

Circle

Ceiling
Vol2 18

Circus

Pendant
Vol1 32
Ceiling
Vol2 42

Circus Solo

Pendant
Vol1 56
Ceiling
Vol2 62

Class

Outdoor
Vol2 456

Cosmos

Pendant
Vol1 160

Dama

Pendant
Vol1 20
Floor & Table
Vol1 364

Dots

Wall
Vol2 242

Dots Glass

Wall
Vol2 252
Outdoor
Vol2 372

Dots Outdoor

Outdoor
Vol2 360

Duo

Ceiling
Vol2 2

Duo Petra

Ceiling
Vol2 12

Empty

Outdoor
Vol2 408

Flamingo

Pendant
Vol1 154

Flamingo Mini

Pendant
Vol1 144

Flat

Pendant
Vol1 94
Floor & Table
Vol1 405
Ceiling
Vol2 68

Funnel

Ceiling
Vol2 172
Wall
Vol2 300

Ghost

Pendant
Vol1 90
Floor & Table
Vol1 438

Guise

Pendant
Vol1 110
Ceiling
Vol2 168
Wall
Vol2 288

Halo

Pendant
Vol1 218
Wall
Vol2 336

Halo Jewel

Pendant
Vol1 224

I.Cono

Floor & Table
Vol1 424
Wall
Vol2 308

Jazz

Floor & Table
Vol1 444

June

Outdoor
Vol2 446

Knit

Pendant
Vol1 26
Floor & Table
Vol1 378

Kontorno

Pendant
Vol1 80
Wall
Vol2 278

Lily

Pendant
Vol1 14
Floor & Table
Vol1 372

Line

Ceiling
Vol2 76

Match

Pendant
Vol1 166

Collections

Mayfair

Pendant
Vol1 194
Floor & Table
Vol1 394

Mayfair Mini

Floor & Table
Vol1 388

Meridiano

Outdoor
Vol2 450

Musa

Floor & Table
Vol1 454
Wall
Vol2 296

North

Pendant
Vol1 264
Floor & Table
Vol1 412
Wall
Vol2 330

Offset

Floor & Table
Vol1 460
Ceiling
Vol2 94
Wall
Vol2 348

Origami

Wall
Vol2 312
Outdoor
Vol2 388

Out

Floor & Table
Vol1 468
Outdoor
Vol2 378

Palma

Pendant
Vol1 170
Ceiling
Vol2 116
Wall
Vol2 256

Palo Alto

Outdoor
Vol2 394

Pin

Floor & Table
Vol1 418
Wall
Vol2 262

Plusminus

Plusminus
Vol1 271

Plusminus Solo

Floor & Table
Vol1 472
Ceiling
Vol2 120
Wall
Vol2 216

Puck

Ceiling
Vol2 192
Wall
Vol2 320

Puck Wall Art

Wall
Vol2 324

Rhythm Horizontal

Pendant
Vol1 182

Rhythm Vertical

Pendant
Vol1 188

Set

Wall
Vol2 274

Skán

Pendant
Vol1 116
Floor & Table
Vol1 434

Slim

Pendant
Vol1 212

Spa

Ceiling
Vol2 182
Wall
Vol2 232

Sticks

Pendant
Vol1 66
Wall
Vol2 340

Sticks Solo

Pendant
Vol1 384
Floor & Table
Vol1 384

Structural

Ceiling
Vol2 176
Wall
Vol2 268

Suite

Floor & Table
Vol1 430
Wall
Vol2 304

Tempo

Pendant
Vol1 234
Wall
Vol2 226

Top

Ceiling
Vol2 36
Wall
Vol2 210

Tube

Pendant
Vol1 106

Tube Free

Pendant
Vol1 100
Ceiling
Vol2 196

Up

Ceiling
Vol2 188

Warm

Pendant
Vol1 122
Floor & Table
Vol1 448

Wind

Pendant
Vol1 230
Outdoor
Vol2 422

Wireflow

Pendant
Vol1 126

Wireflow Chandelier

Pendant
Vol1 140

Wireflow Free

Pendant
Vol1 134

Wireflow Lineal

Pendant
Vol1 130

Pendant

Pendant

| | | | |
|--------------------------|----------------------|-----------------------------|-------------------------------|
| Algorithm Free 200 | Flat 94 | Palma 170 | Tube Free 100 |
| Algorithm Grid 206 | Ghost 90 | Rhythm Horizontal 182 | Warm 122 |
| Array 2 | Guise 110 | Rhythm Vertical 188 | Wind 230 |
| Bigger 176 | Halo 218 | Skam 116 | Wireflow 126 |
| Bind 240 | Halo Jewel 224 | Slim 212 | Wireflow Chandelier 140 |
| Circus 32 | Knit 26 | Sticks 66 | Wireflow Free 134 |
| Circus Solo 56 | Kontorno 80 | Sticks Solo 74 | Wireflow Lineal 130 |
| Cosmos 160 | Lily 14 | Tempo 234 | |
| Dama 20 | Match 166 | Tube 106 | |
| Flamingo 154 | Mayfair 194 | | |
| Flamingo Mini 144 | North 264 | | |

Array



Design by Umut Yamac.

A striking pendant of impressive proportions, Array is an exploration of thread and its potential to create lightweight and dynamic sculptures of light.



Composed of an array of fine technical threads pulled taut between two aluminum rings, Array presents a wide range of conical and cylindrical silhouettes that can be combined together to form a compelling installation.

The spacing distribution of the threads creates translucency and volume, whilst the layering effect gives the illusion of movement. Suspended overhead, Array emits a pleasant downlight projected from an invisible source concealed within the lower ring.

At the same time, indirect light washes upwards in a gradient of colour, enveloping rather than invading the space it occupies.

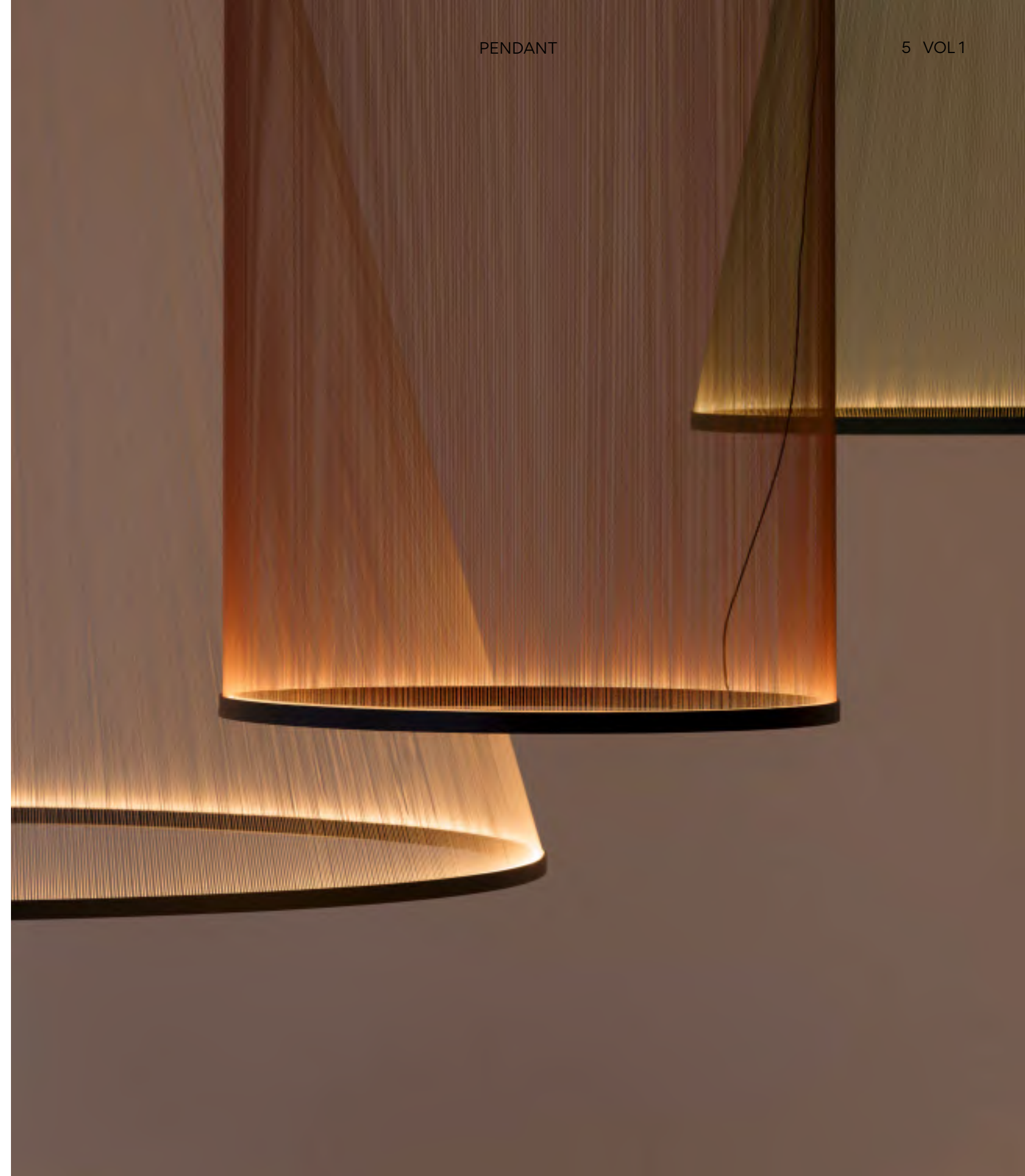







Height 70 cm



1800

Ø 37 cm



1815

Ø 54,5 cm

Height 110 cm



1805

Ø 37 cm



1820

Ø 54,5 cm



1830

Ø 82,5 cm



1840

Ø 124 cm

Height 190 cm



1810

Ø 37 cm



1825

Ø 54,5 cm



1835

Ø 82,5 cm



1845

Ø 124 cm

Height 70 cm



1850

Ø 54,5 cm

Height 110 cm



1855

Ø 54,5 cm



1865

Ø 82,5 cm



1875

Ø 124 cm

Height 190 cm



1860

Ø 54,5 cm



1870

Ø 82,5 cm



1880

Ø 124 cm

Threads.

- 24 Beige M1 (NCS S 2005-Y50R)
- 37 Terra Red (NCS S 4040-Y70R)
- 47 Green L1 (NCS S 4005-G80Y)

Rings.

- 11 Black (S 8500-N)

Textile threads: Polyester FR
(Flame retardant)
Upper ring: Aluminum
Bottom ring: Brass

LED Colour Temperature

2700 K
CRI>90

Control

Analog: Push; 1-10V
Digital: DALI-2
Smart: Casambi

Electrical connection options



Remote

Built-in

Surface

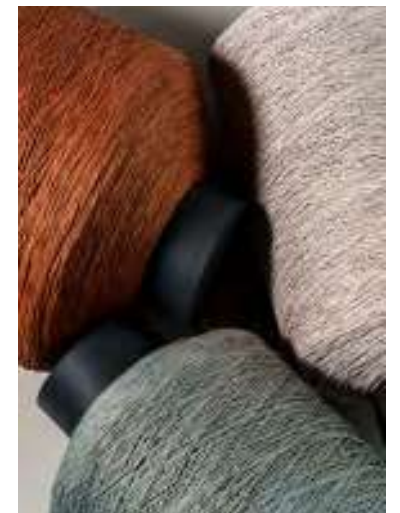

Lily



Design by Ludovica+Roberto Palomba.

The simplicity of Lily's refined silhouette makes this fixture ideal for an elegant interior with a relaxed ambience. Suspended from a high ceiling or positioned strategically about the room, its graceful glass diffuser radiates a sense of warmth and wellbeing.







5730
Ø 49 cm

- 11 Black (NCS S 8500-N)
- 25 Beige D1 (NCS S 4005-Y50R)

Shade: Triple opal blown glass
Body: Aluminum



LED Colour Temperature
2700 K
CRI>90

Control
Analog: 1-10V; Push
Digital: DALI-2
Smart: Casambi



Electrical connection options

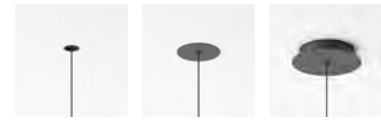

Remote Built-in Surface



Dama



Design by Ludovica+Roberto Palomba.

Dama is a homage to the classic lamp, ideal for shaping an intimate atmosphere with an elevated aesthetic. Combining technical quality with a layer of warmth and intimacy, the collection connects the charm of tradition with the finesse of contemporary lighting design.





Cutting-edge invisible technology allows Dama's circular light source to radiate with a gentle, uniform glow from within. Suspended from a micro-thin cable that's almost invisible to the eye, the pendant exhibits an ethereal quality, its graceful silhouette looming overhead.

- 11 Black (S 8500-N)
- 25 Beige D1 (NCS S 4005-Y50R)

Shade: Paper
Body: Aluminum

LED Colour Temperature
2700 K
CRI>90

Control
Analog: Push; 1-10V
Digital: DALI-2
Smart: Casambi

Electrical connection options



Remote Built-in

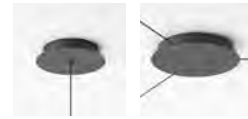

Surface Free Wire

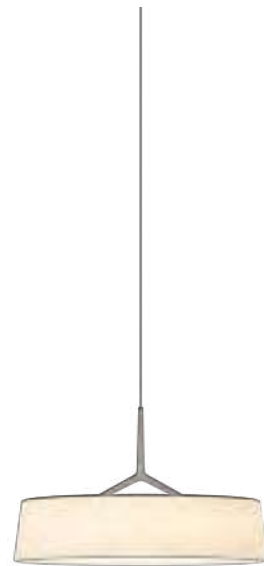

3235
Ø 45 cm

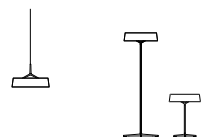

Pg 20 VOL 1 Pg 364 VOL 1

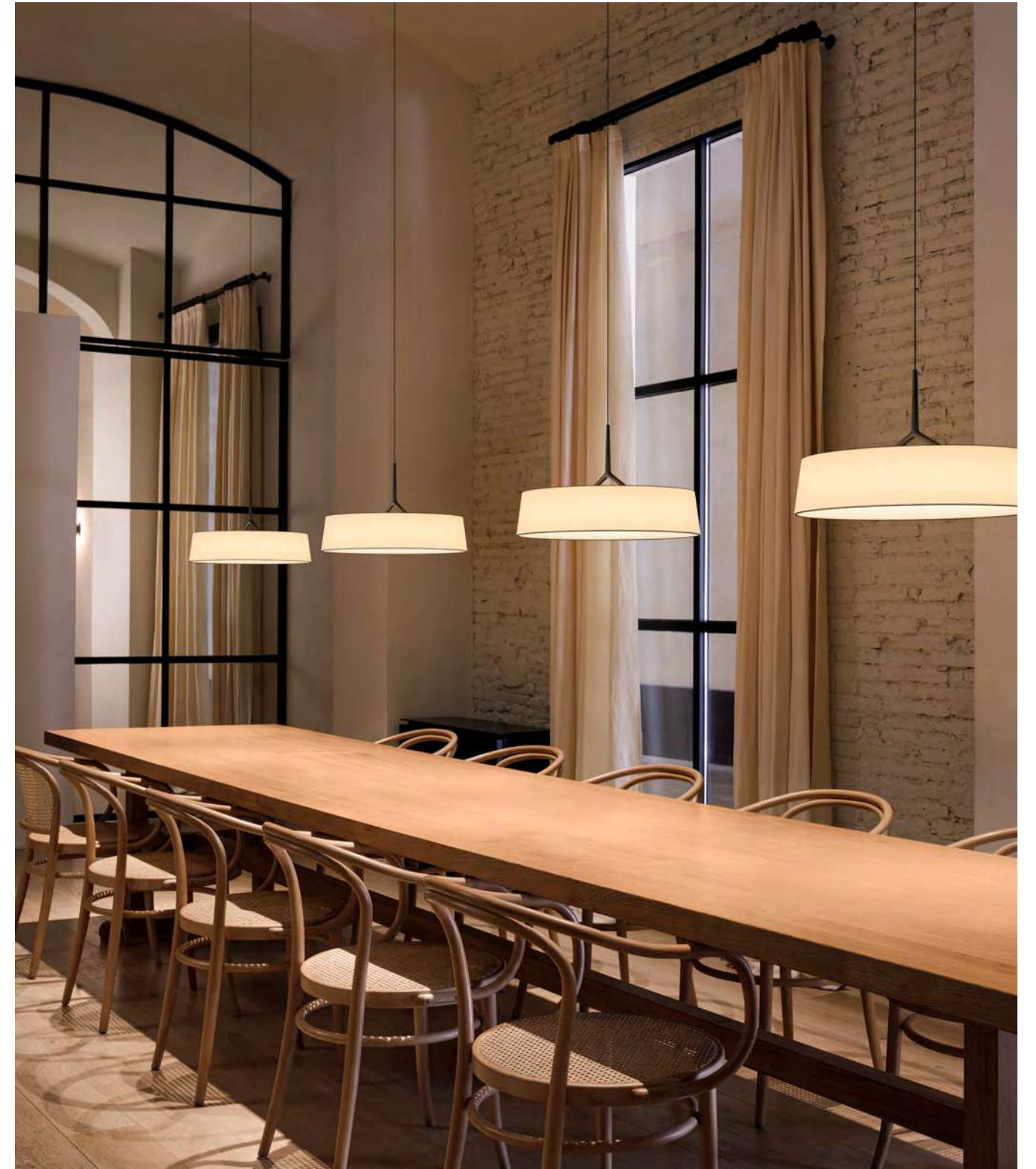

Knit



Design by Meike Harde.

Light, materiality and tangibility collide with the Knit collection. Its texture is magnetic, calling out for us to touch its surface, to feel its warmth and to keep it close. Light seeps outwards through the fabric transmitting a soft 360° glow.







While the urchin, a symbol of fertility, conceals a soft inside beneath its protective outer shell, Knit delights in the femininity and softness of its outer layer. It exudes intimacy, comfort and familiarity.



7450
Ø 45 cm

7455
Ø 45 cm

7460
Ø 45 cm



7470
Ø 65 cm



7475
Ø 65 cm

● 24 Beige M1 (NCS S 2005-Y50R)

Fabric shade: PES FR
Shade: PE- Polyethylene
Diffuser: PMMA
Diffuser ring: ABS

LED Colour Temperature
2700 K
CRI>90

Control
Analog: 1-10V
Digital: DALI-2
Smart: Casambi

Electrical connection options

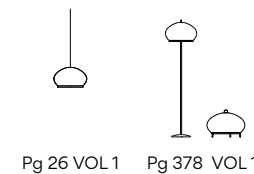
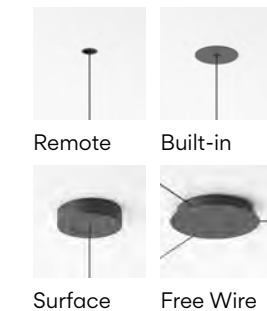

Pg 26 VOL1 Pg 378 VOL1

Circus

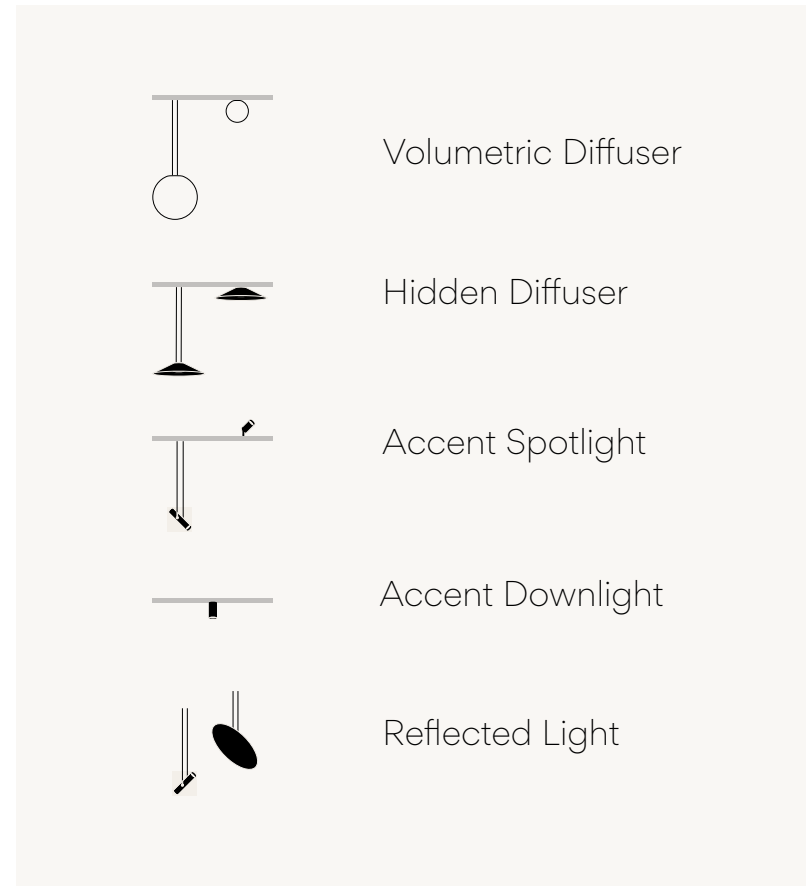

Design by Antoni Arola.

Circus is defined by its minimalist structure and signature conductive bar, delicately balanced by opposing elements to create a festival of light. A creative toolkit full of possibilities to explore and enjoy that offers total freedom of composition, multiple components and a myriad of diffuse and accented lighting effects.





Its structure is developed both vertically and horizontally and combines volumetric diffusion effects, hidden diffusers, spot and indirect lighting. This system turns the professional into a composer of atmospheres, where object luminaires can be combined with functional elements.



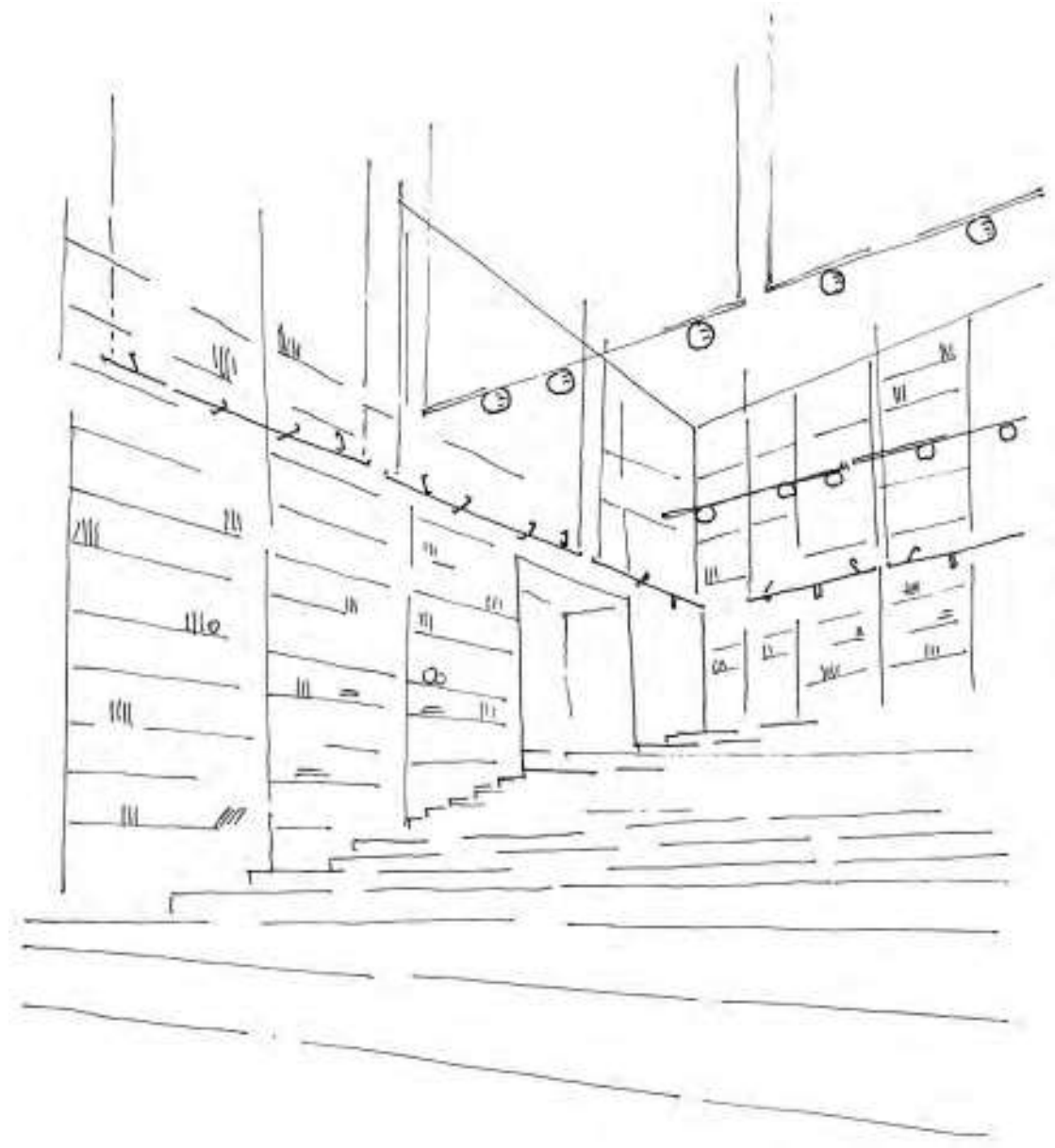

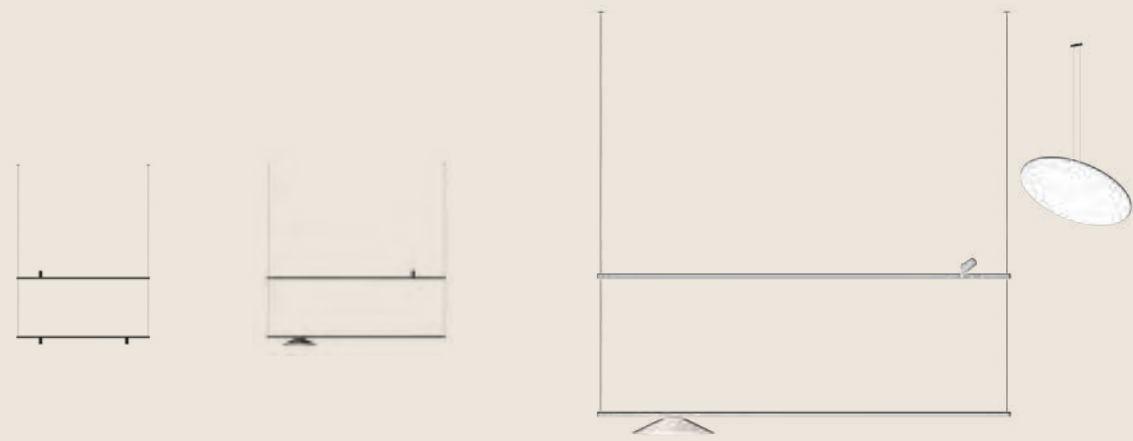



Suspended from the ceiling and positioned at any angle, the discs reflect rather than emit light. Lustrous and ethereal, these halos cast spherical shadows evocative of a circus performance or lunar eclipse when positioned above a spot.

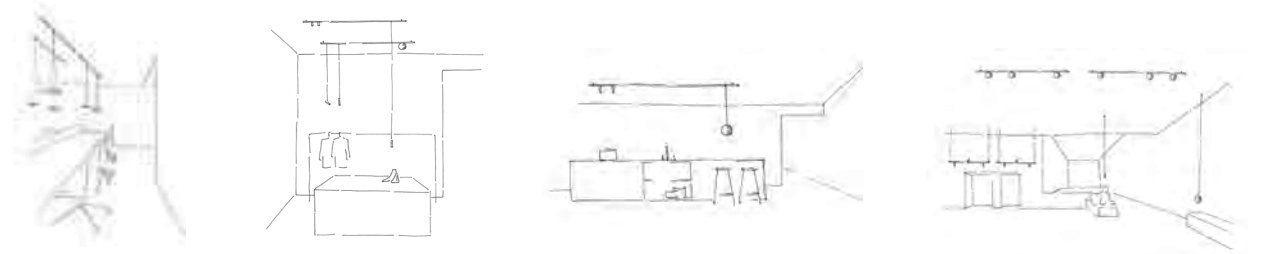



Suspended in parallel to form an equilibrium or poised in asymmetrical harmony, the slender and distinctive bar amplifies the possibilities for shaping a space. Whether composed independently, as a pair or fixed to the ceiling, it conducts electricity and transports light to different points of interest, creating a visual hierarchy within the space and between the surrounding objects.







Circus offers a variety of fixtures that can be built into the conductive bar, suspended from a track or hung directly from the surface of the ceiling. The bar amplifies the possibilities for shaping a space by conducting electricity and transporting light to wherever it is needed.

- 11 Black (NCS S 8500-N)
- 24 Beige M1 (NCS S 2005-Y50R)

Electrical connection options

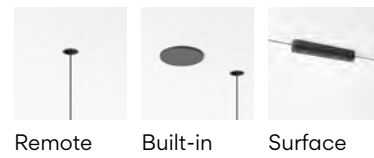

Pendant Tracks

A358 (H 3m)
A359 (H 9m)

110 cm



A364 (H 3m)
A365 (H 9m)

150 cm



A370 (H 3m)
A371 (H 9m)

200 cm



A376 (H 3m)
A377 (H 9m)

110 cm

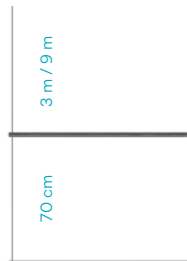

A382 (H 3m)
A383 (H 9m)

150 cm

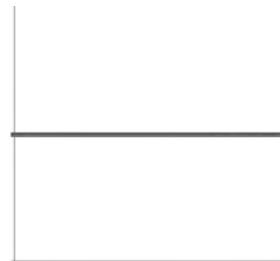

A388 (H 3m)
A389 (H 9m)

200 cm

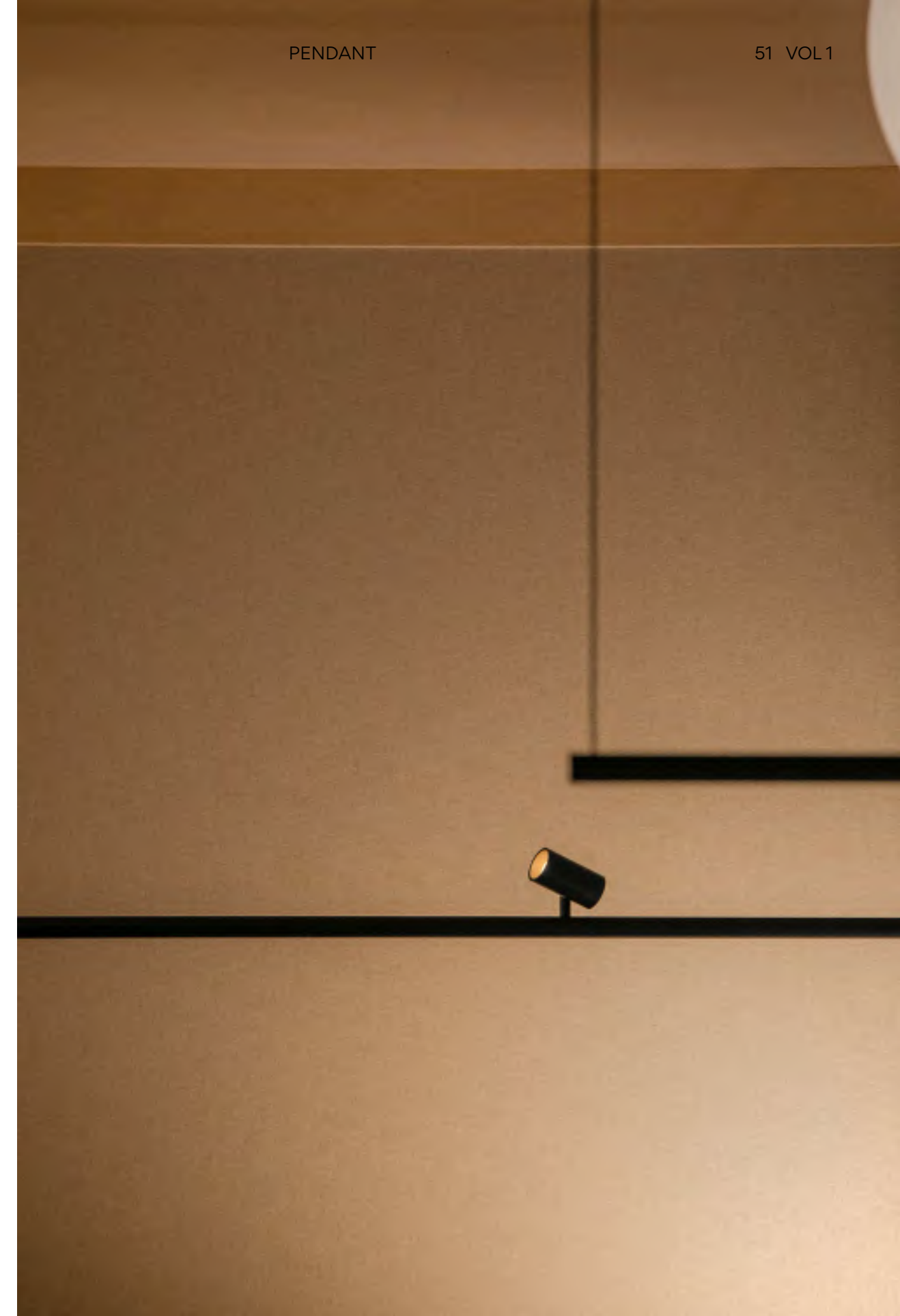

With a choice of black (11) or beige (24) finishings and dimming control, Circus offers a variety of fixtures that can be built into the conductive bar, suspended from a track or hung directly from the surface of the ceiling. With a traditional light rail the connection is visible from below, but with Circus, the luminaires can be connected to the bar from above, sealed with a cover and with pendants passing seamlessly through the lower section. This innovation has a significant impact on the aesthetic purity of the design.

- 11 Black (NCS S 8500-N)
- 24 Beige M1 (NCS S 2005-Y50R)

Volumetric Diffuser

Diffuser: PE- Polyethylene

Hidden Diffuser

Shade: Aluminum

Diffuser: PC- Polycarbonate

Spots / Downlight

Body: Aluminum

Lens: PMMA

Pendant Spot

Body: Zinc Alloy

Lens: PMMA

LED Colour Temperature

Volumetric Diffuser / Hidden Diffuser

Static White

2700 K; 3000 K; 3500 K

Tunable White (1800 K- 4000 K)

Tunable Red (Red - 2700 K)

Spots / Downlight

Static White

2700 K - 680 lm

3000 K - 711 lm

3500 K - 737 lm

7,2W

Only ref. 0131, 0132,

0141, 0142, 0152 and 0153

Tunable White (1800 K - 4000 K)

Smart (P2P)

308 lm - 504 lm 5,5W

Only ref. 0131, 0141 and 0152

Tunable Red (Red - 2700 K)

Smart (P2P)

155 lm - 581 lm 7W

CRI>90

Control

Digital: DALI-2 (P2P)

Smart: Casambi (simultaneous line);

Casambi (P2P); ProtoPixel* (P2P)

*ProtoPixel products are compatible with all other DALI-2 products via a designated gateway (please consult us)

Updated detailed spec sheets on vibia.com

Volumetric Diffuser

PENDANT



Hidden Diffuser

PENDANT

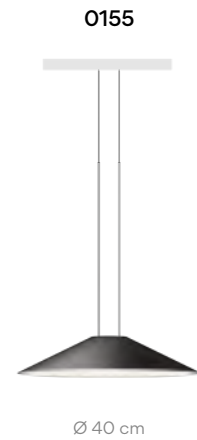

Accent Spotlight

PENDANT

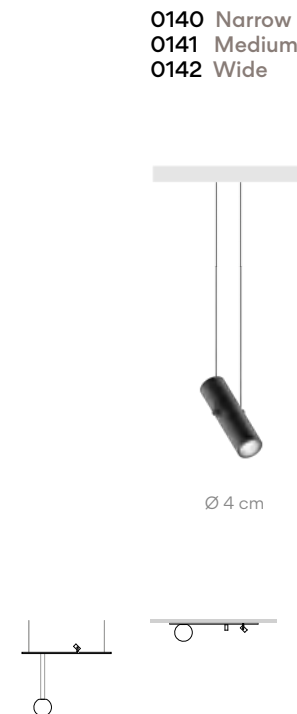

DIRECT TO TRACK



Accent Downlight

DOWNLIGHTS



DIRECT TO TRACK



DIRECT TO TRACK

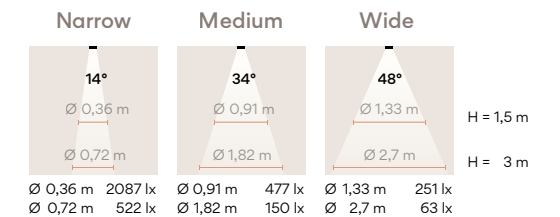

Suspended from the ceiling and positioned at any angle, a range of reflector discs reflect diffuse light from a spot angled towards them. Lustrous and ethereal, they cast a spherical shadow on the adjacent surface like a lunar eclipse.

● 11 Black
(Bottom face: White / Top face: Black)

Reflected Light

LIGHT REFLECTOR

A146



Ø 40 cm H 9 m

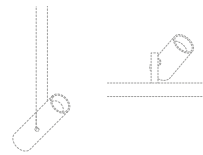

A147



Ø 60 cm H 9 m

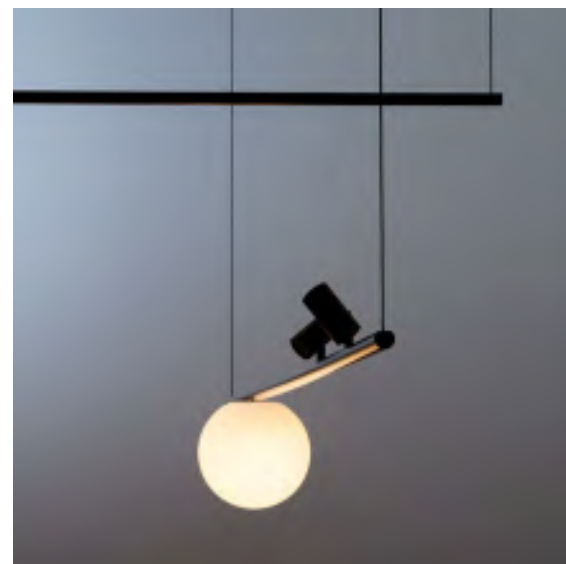
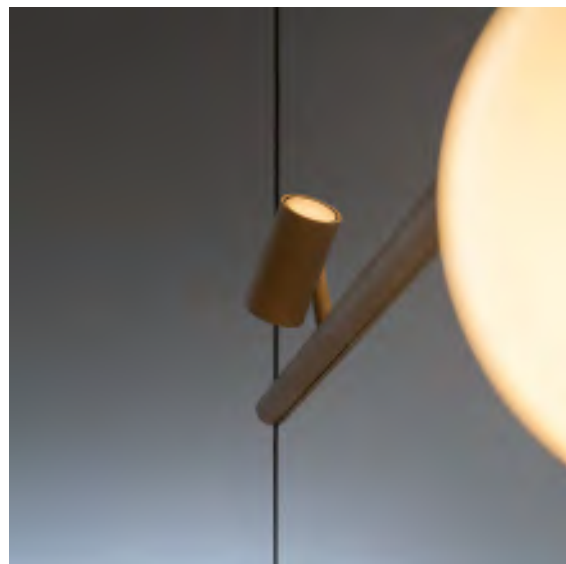
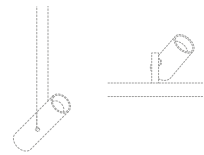

Dynamic light

Dynamic light allows professionals to play with subtle degrees of intensity and colour temperature to recreate a subtle ambience for every scene within a lighting project

A source of emotion

Static, tunable white and tunable red

Designing an atmosphere of wellbeing is based on two main axes: **space** and **time**. The axis of time implies the concept of dynamic light.

Atmosphere design is intentional, depending on the **design of different scenes according to the specific use of a space** as it evolves throughout the day. Light is dynamic because ambience also depends **on the time of day** and on the influence of the natural light at every moment.

Throughout the day our circadian rhythms respond primarily to light, which regulates our sense of physical and mental wellbeing.

Vibia's approach to coloured light invites the use of colour and intensity to create and experience different atmospheres, making them as natural and subtle as possible.

Colour is a source of emotion, it can instantly set a mood, convey a feeling or generate a sense of wellbeing.



Circus product options offer a range of static white in three different temperatures as well as the option of tunable white. Tunable lighting allows for comprehensive temperature regulation: colour temperature can be precisely tuned depending on the desired atmosphere for every scene.

The **tunable red** option allows you to glide from red to white, exploring a range of relaxing and cosy effects. Tunable white lighting option allows for comprehensive temperature regulation depending on the atmosphere of every scene.

Static White

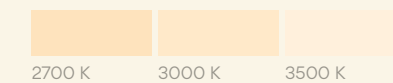

Tunable White

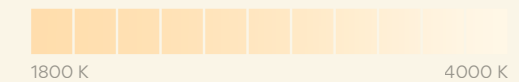

Tunable Red



Contact Vibia Support Service at vibia.com for any kind of assistance or recommendation when designing an atmosphere of wellbeing, or if you require support with control system approach.

Circus Solo

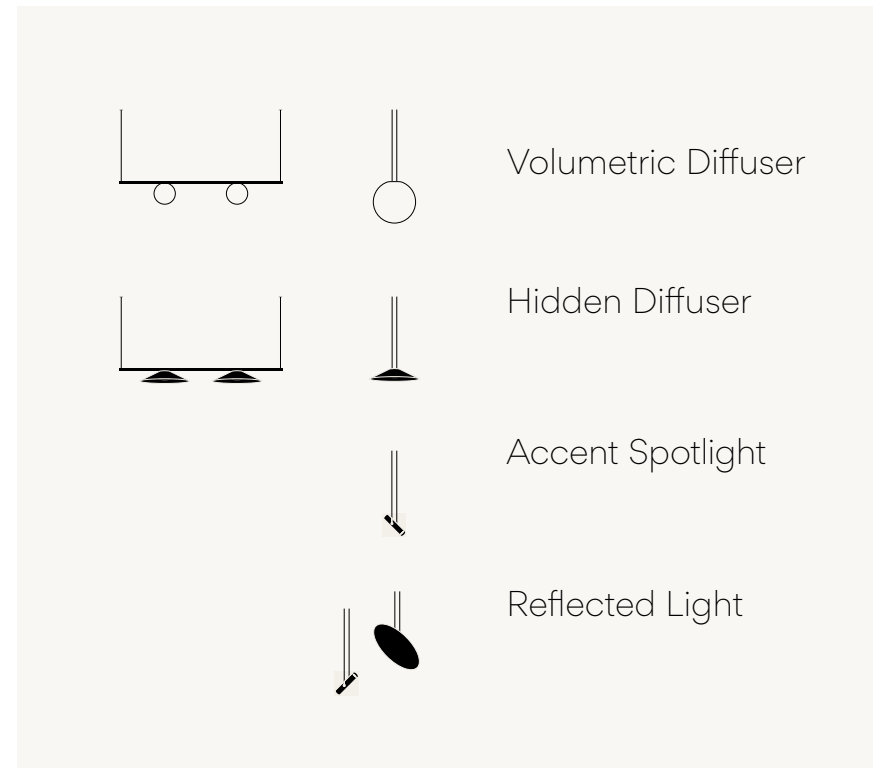

Design by Antoni Arola.

The Circus system incorporates a range of independent elements that can be surface mounted to the ceiling, including spots, downlights and general lighting fixtures. This line allows professionals to create harmonic compositions and subtle atmospheres that break with the standards.



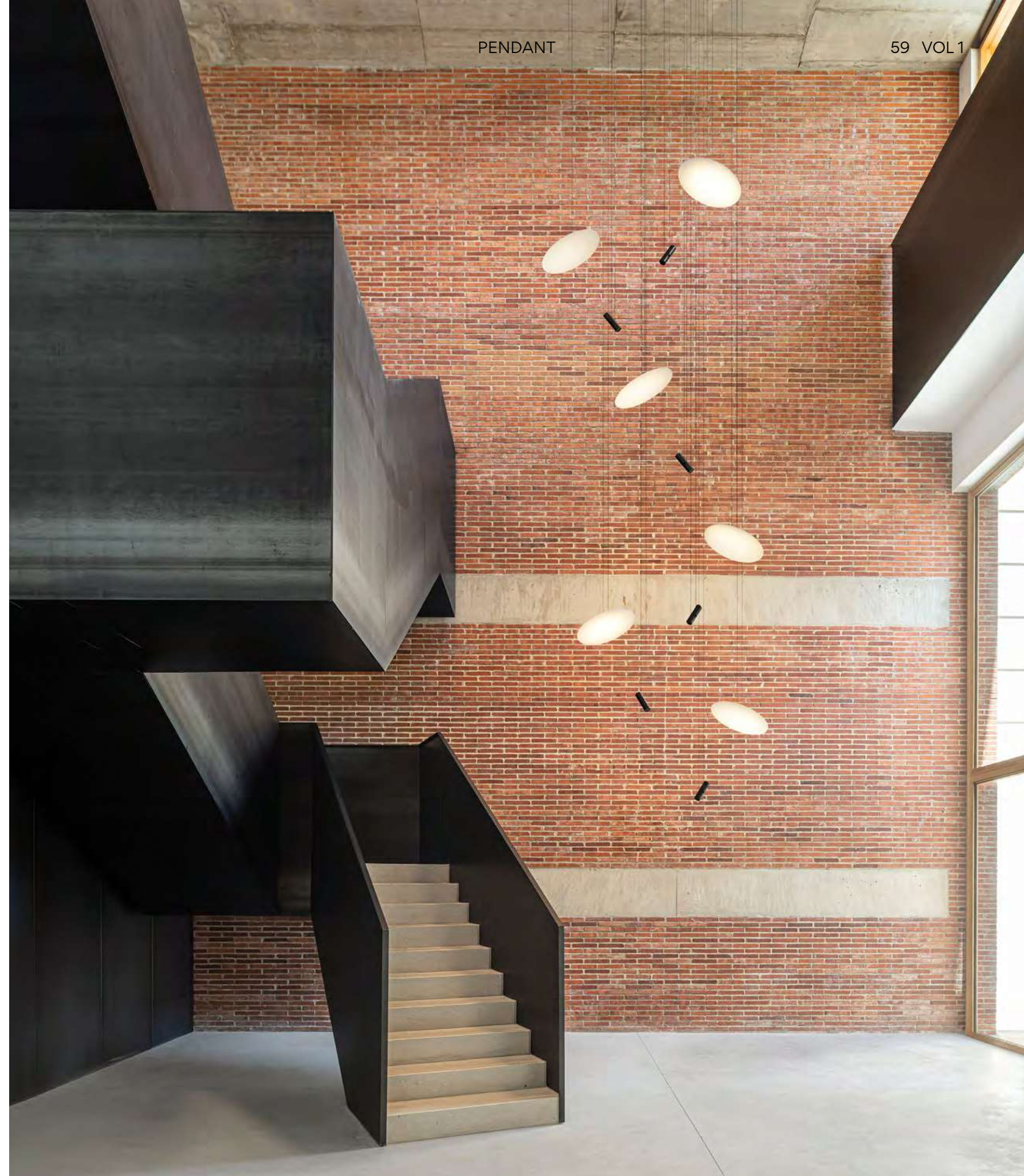

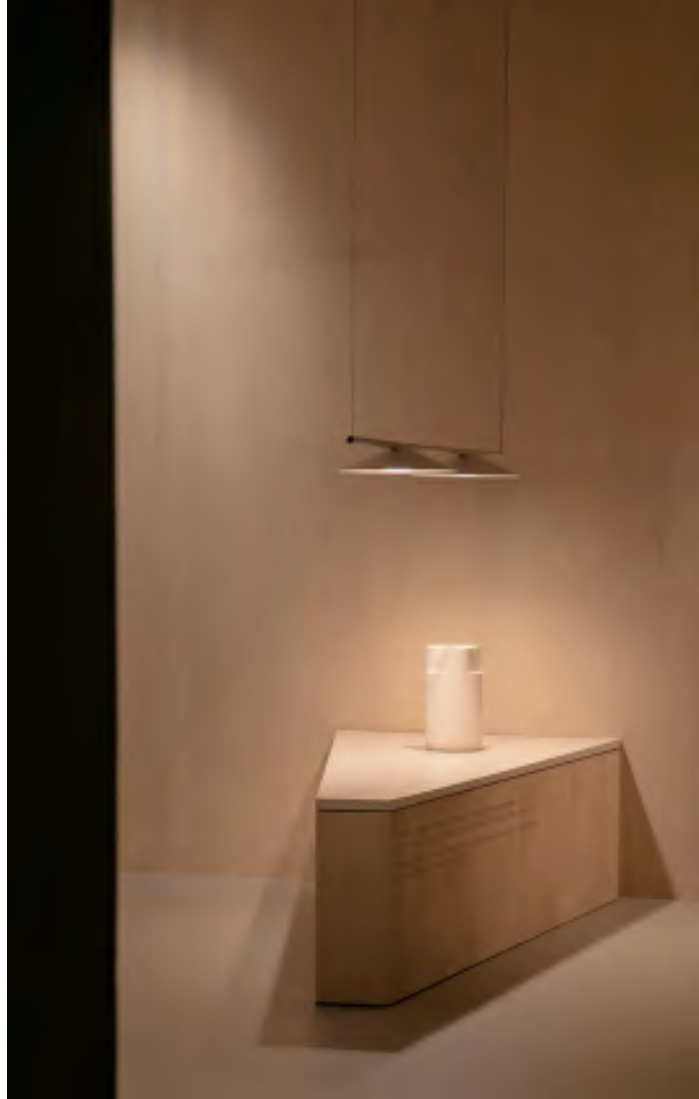

- 11 Black (NCS S 8500-N)
- 24 Beige M1 (NCS S 2005-Y50R)

Volumetric Diffuser

Diffuser: PE- Polyethylene
Top cover: Aluminum

Hidden Diffuser

Shade: Aluminum
Diffuser: PC- Polycarbonate
Top cover: Aluminum

Spots

Body: Zinc Alloy
Lens: PMMA

LED Colour Temperature

Volumetric Diffuser / Hidden Diffuser

Static White
2700 K; 3000 K; 3500 K
Tunable White (1800 K- 4000 K)
Tunable Red (Red - 2700 K)

Pendant Spot

Static White
2700 K - 680 lm
3000 K - 711 lm
3500 K - 737 lm
7,2W

Only ref. 0177 and 0178
Tunable White (1800 K - 4000 K)
Smart
308 lm - 504 lm 5,5W

Only ref. 0177
Tunable Red (Red - 2700 K)
Smart
155 lm - 581 lm 7W

CRI>90

Control

Analog: Push
Digital: DALI-2*
Smart: Casambi;

*DALI-2 products are compatible (via a designated gateway) with all ProtoPixel dynamic-light solution products.

Electrical connection options



Remote Built-in Surface

Accent Spotlight

Surface Built-In

- 0176 Narrow
- 0177 Medium
- 0178 Wide

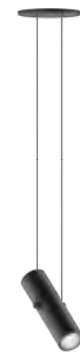

Ø 4 cm

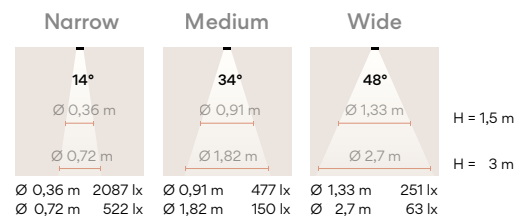

Pg 56 VOL 1 Pg 62 VOL 2

Volumetric Diffuser

Surface Built-In

0185

0187



Ø 20 cm

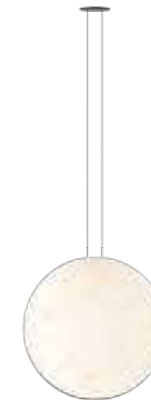

Ø 45 cm

Surface Built-In Remote

0193

150 x max. 200 cm



Ø 20 cm

Hidden Diffuser

Surface Built-In

0182

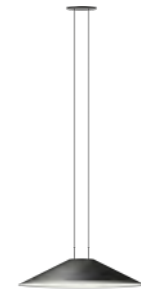

Ø 40 cm

Surface Built-In Remote

0196

150 x max. 200 cm



Ø 40 cm

Suspended from the ceiling and positioned at any angle, a range of reflector discs reflect diffuse light from a spot angled towards them, rather than emitting their own light. Lustrous and ethereal, they cast a spherical shadow on the adjacent surface like a lunar eclipse.

● 11 Black
(Bottom face: White / Top face: Black)

Reflected Light

LIGHT REFLECTOR

A146

Ø 40 cm H 9 m

A147

Ø 60 cm H 9 m

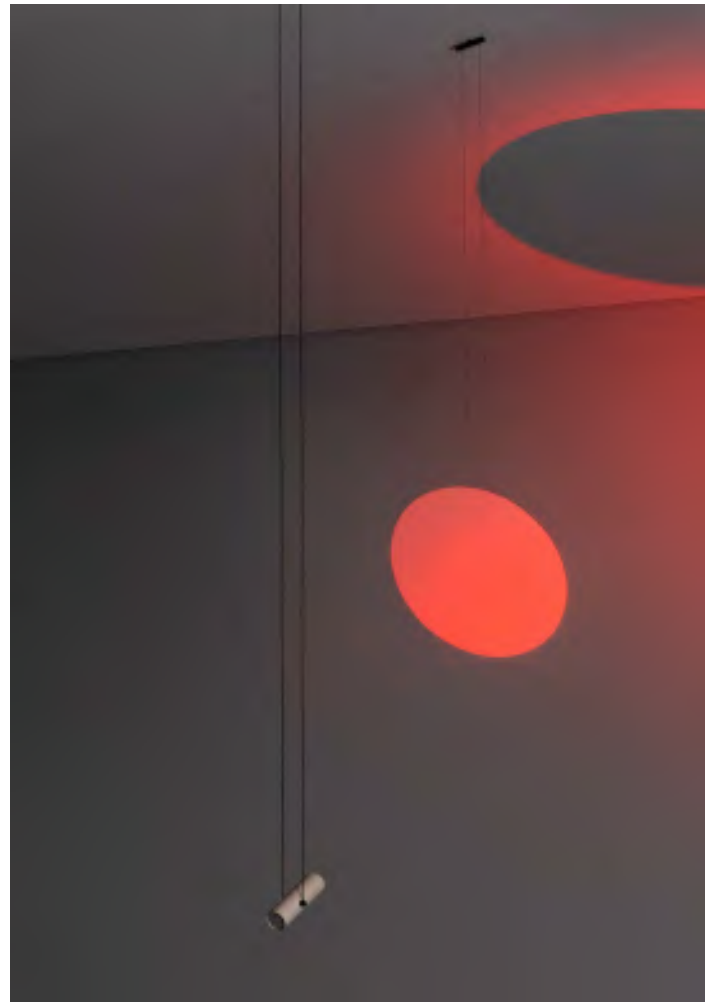

Dynamic light

Dynamic light allows professionals to play with subtle degrees of intensity and colour temperature to recreate a subtle ambience for every scene within a lighting project

A source of emotion

Static, tunable white and tunable red

Designing an atmosphere of wellbeing is based on two main axes: **space** and **time**. The axis of time implies the concept of dynamic light.

Atmosphere design is intentional, depending on the **design of different scenes according to the specific use of a space** as it evolves throughout the day. Light is dynamic because ambience also depends **on the time of day** and on the influence of the natural light at every moment.

Throughout the day our circadian rhythms respond primarily to light, which regulates our sense of physical and mental wellbeing.

Vibia's approach to coloured light invites the use of colour and intensity to create and experience different atmospheres, making them as natural and subtle as possible.

Colour is a source of emotion, it can instantly set a mood, convey a feeling or generate a sense of wellbeing.



Circus product options offer a range of static white in three different temperatures as well as the option of tunable white. Tunable lighting allows for comprehensive temperature regulation: colour temperature can be precisely tuned depending on the desired atmosphere for every scene.

The **tunable red** option allows you to glide from red to white, exploring a range of relaxing and cosy effects. Tunable white lighting option allows for comprehensive temperature regulation depending on the atmosphere of every scene.

Static White

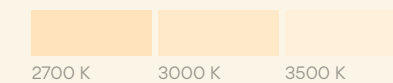

Tunable White

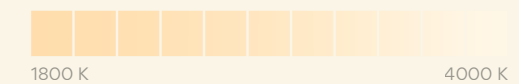

Tunable Red



Sticks

Design by Arik Levy.

Fusing technology, space, and architecture, Sticks offers a creative toolkit for integrating light elements into an interior environment. Graphic in form, the collection consists of minimalist Aluminum rods that transform linear light into a floating sculpture.







● 11 Black (NCS S 8500-N)

Stick: Aluminum
Diffuser: PC- Polycarbonate

LED Colour Temperature
2700 K; 3000 K; 3500 K
CRI>90

Control
Surface canopy, Built-in, Remote driver:
1-10V.

Electrical connection options



Surface canopy Built-in disc S Remote driver Built-in Micro



Horizontal Pendants version with a UGR index <19 available.

Create your own composition easy and quick at vibia.com selecting the option that best fits your needs.

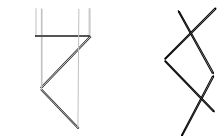

Connecting space application

Custom configurations include ceiling-to-ceiling, wall-to-wall, floor-to-wall, wall-to-ceiling, or suspended from the ceiling into open space. Through their physical form and the light they cast, they create and disrupt architectural planes.

Connectable

The Sticks collection has three sizes: 1.5 m , 2 m, or 3 m, and they can be connected one to each other to a total maximum length of 6.5 meters per electrical connection.

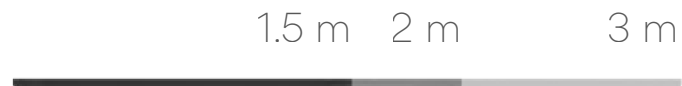

Pendants-Wall

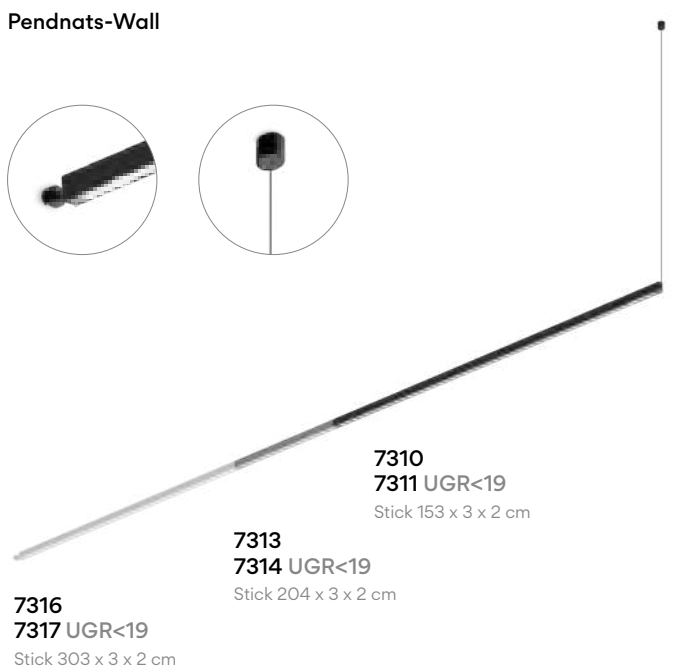
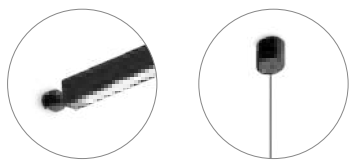

Sticks are connected one to each other with a 15 cm length cord.

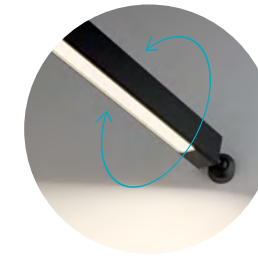

Each stick rotates on its own axis, allowing light to be directed precisely where needed.

Vertical Pendant

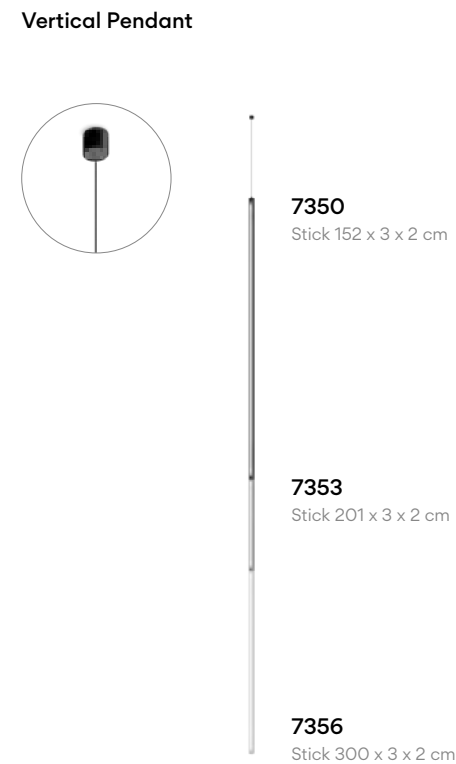
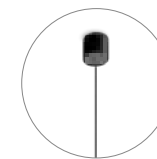

Pendants-Pendants

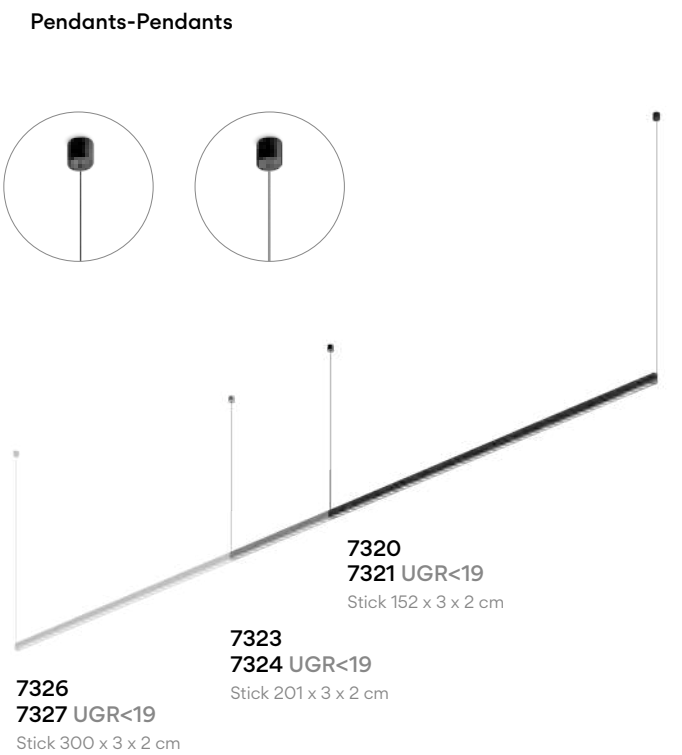
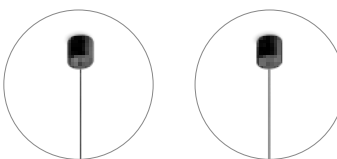



Sticks Solo

Design by Arik Levy.

A pure solution for a minimalist interior, Sticks Solo features a range of horizontal pendants of various lengths and incorporates a range of electrical connection options for seamless integration with the surrounding architecture.

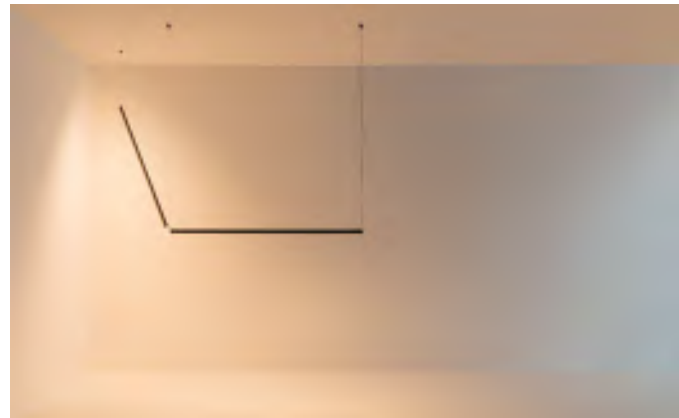

The stick rotates on its own axis, allowing light to be directed precisely where needed

● 11 Black (NCS S 8500-N)

Stick: Aluminum
Diffuser: PC- Polycarbonate

LED Colour Temperature

2700 K; 3000 K; 3500 K
CRI>90

Control

Analog: 1-10V
Digital: DALI-2
Smart: Casambi

Electrical connection options



Surface canopy Built-in disc S Remote Micro Remote XXS

7360
7361 UGR<19
152 x 2 x 3 cm

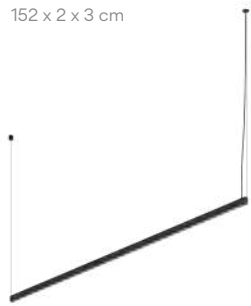

7363
7364 UGR<19
201 x 2 x 3 cm



7365
7366 UGR<19
307 x 2 x 3 cm



7368
7369 UGR<19
405 x 2 x 3 cm

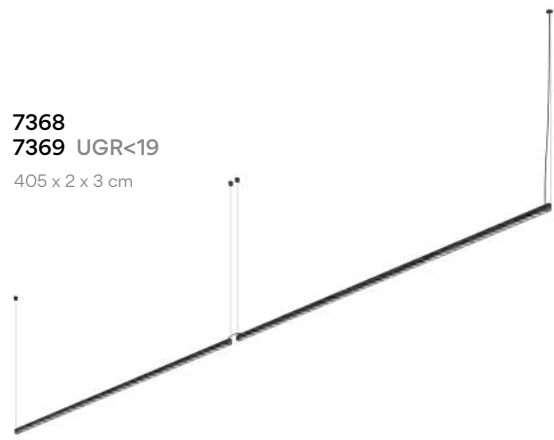

Linear flat
diffuser



Horizontal Pendants
version with a UGR
index <19 available.

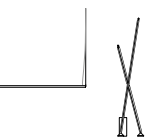

Kontorno

Design by Sebastian Herkner.

Consisting of an elegant linear framework complemented by a cylindrical diffuser or curved reflector, the Kontorno collection envelops the light source it contains, offering diffuse, balanced illumination.



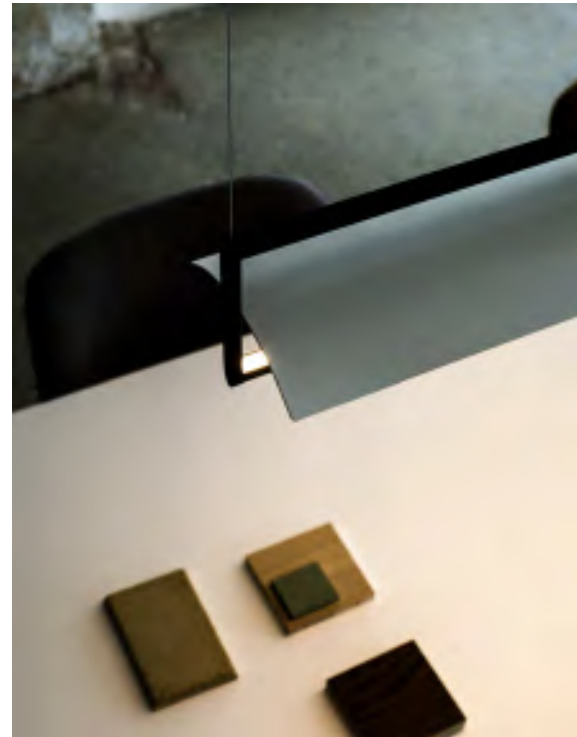

The Kontorno pendant consists of a streamlined silhouette that appears to float from invisible cables. Embedded with LEDs, curved volumes are balanced by sleek geometric architecture. The reflector lends an intentional look of raining light.

● 11 Black (NCS S 8500-N)

Concave shade: Aluminum
 Diffuser: PC- Polycarbonate
 Pendant structure: Steel
 Canopy: Aluminum

LED Colour Temperature

2200 K; 2700 K; 3000 K; 3500 K
 CRI>90

Control

Analog: Push; 1-10V
 Digital: DALI-2
 Smart: Casambi

Aluminum Shade

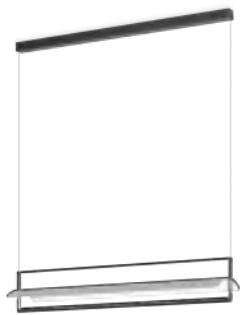

6434
92 cm



6436
122 cm



6438
162 cm

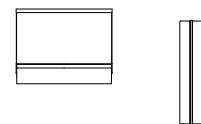

Pg 80 VOL1 Pg 278 VOL2





The Kontorno pendant consists of a streamlined silhouette that appears to float from invisible cables. Embedded with LEDs, curved volumes are balanced by sleek geometric architecture. The cylindrical diffuser evenly illuminates the surrounding space.

● 11 Black (NCS S 8500-N)

Glass shade: Opal triplex
Diffuser: PC- Polycarbonate
Pendant structure: Steel
Canopy: Aluminum

LED Colour Temperature
2200K; 2700 K; 3000K
CRI>90

Control
Analog: Push; 1-10V
Digital: DALI-2
Smart: Casambi

Glass Shade



6474
92 cm



6476
122 cm

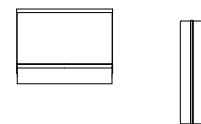

Pg 80 VOL1 Pg 278 VOL2



Ghost

Design by Arik Levy.

A study in contrasts, the Ghost collection embodies both spirit and materiality, discretion and presence. A contemporary reimagining of the grand lights that once graced entryways and living areas, its sensuous form radiates with a warm, welcoming glow.





4987

Ø 47,5 cm

True to its namesake, the Ghost pendant possesses an ethereal presence. Large in scale yet elegant in sensibility, the luminaire floats overhead from nearly invisible cables to provide a striking focal point in any space. Crafted meticulously of mouth-blown opal triplex glass, Ghost's rich, smooth material generates a warm, ambient glow.

● 11 Black (NCS S 8500-N)

Diffuser: Opal Glass
Metal parts: Aluminum

LED Colour Temperature

2700 K
CRI>90

Control

Analog: Push; 1-10V
Digital: DALI-2
Smart: Casambi

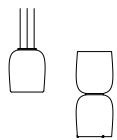

Pg 90/438 VOL1



Flat

Design by Ichiro Iwasaki.

A study in geometry, the Flat collection features distinctive, disc-shaped diffusers that form horizontal planes of light, infusing a space with pools of soft illumination.





INDIVIDUAL MODEL



5930
Ø 90 cm



5935
Ø 40 cm



5940
Ø 55 cm

- 13 Off-White (NCS S 1000-N)
- 37 Terra Red (NCS S 4040-Y70R)
- 47 Green L1 (NCS S 4005-G80Y)

Shade: Aliminum
 Diffuser: PC- Polycarbonate
 Pendant structure: Steel
 Canopy: Aluminum

LED Colour Temperature
 2700 K; 3500 K
 CRI>90

Control
 Analog: Push; 1-10V
 Digital: DALI-2
 Smart: Casambi

Ref. 5935 and 5940.
Electrical connection options

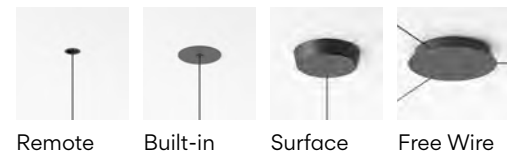

Upper side of the disc available in:
 Off-White, Terra Red y Green L1.



MULTIPLE MODELS

Set your composition to vibia.com

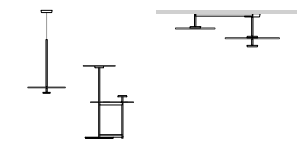
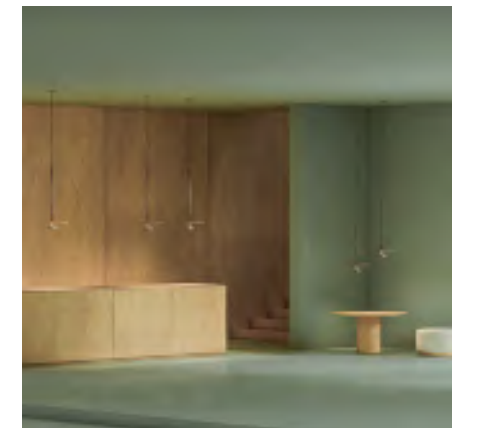
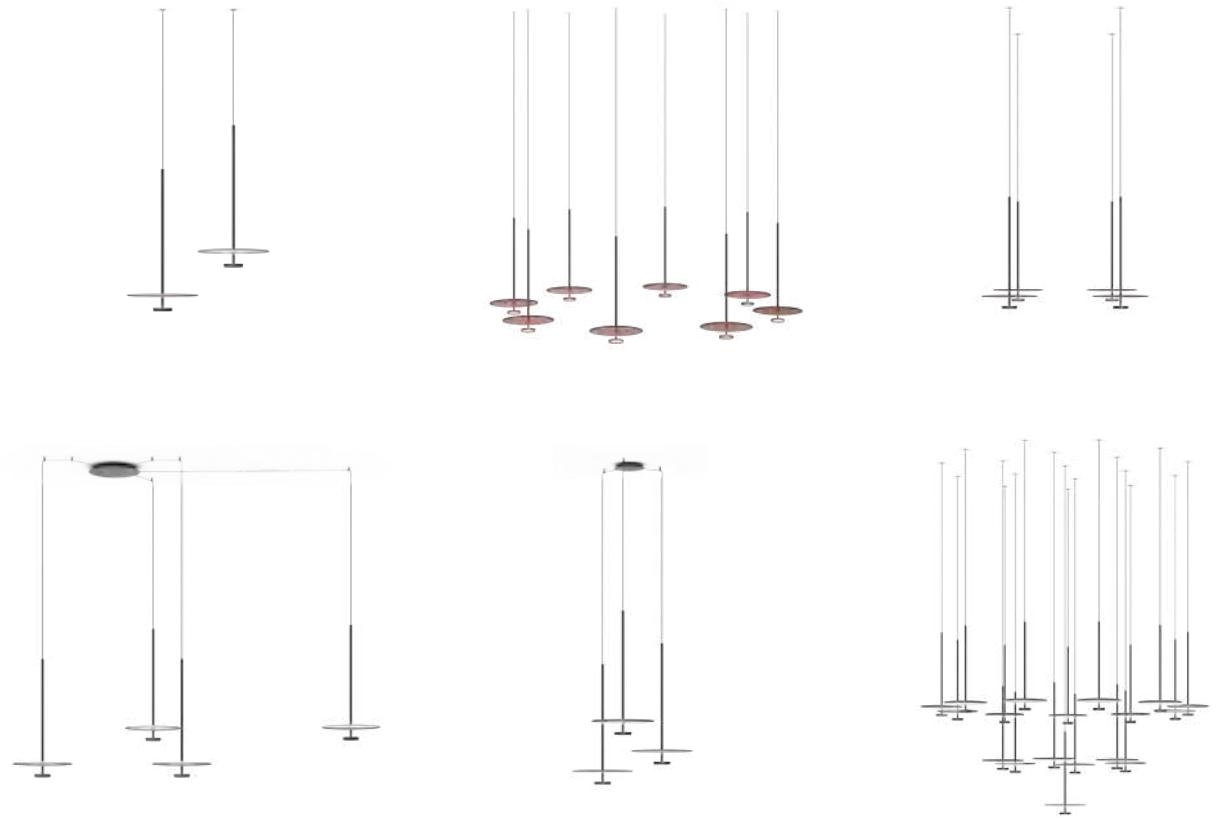

Tube Free



Design by Ichiro Iwasaki.

Tube Free seemingly emancipates the tube from its point of connection to create a landscape of independent pendants. When set out over a space, the arrangement of numerous tubes of equal or varying heights creates a delicate structure and facilitates a harmonious congregation of shades.



Composed of two different sized luminaires and a black tube that extends vertically, it conducts light to wherever it is required, integrating within the architecture of any interior.

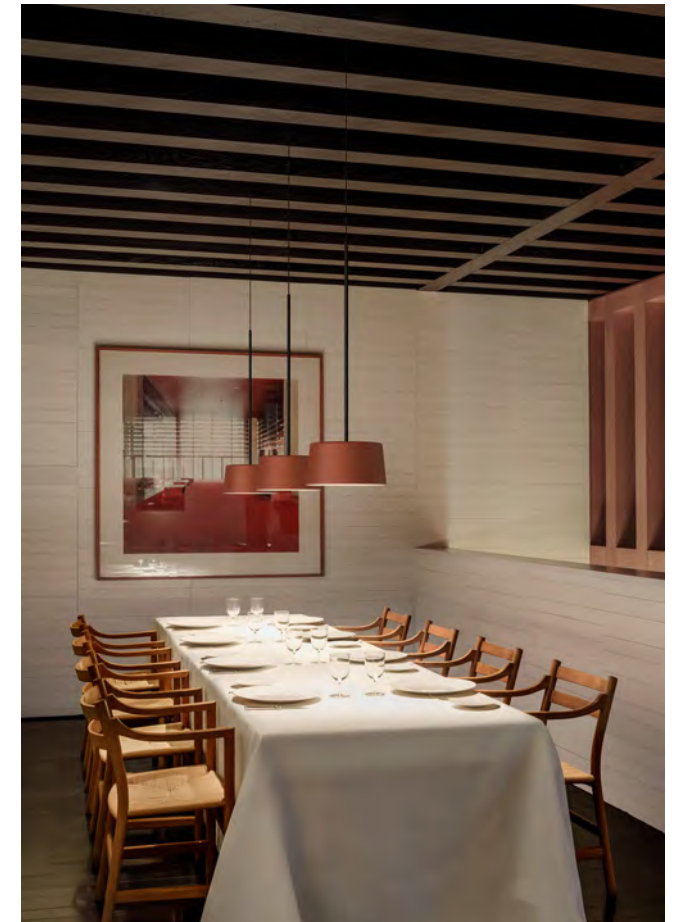

INDIVIDUAL MODEL



6160
Ø 22 cm



6165
Ø 28,5 cm

- 10 White (NCS S 0300-N)
- 15 Grey L2 (NCS S 2500-N)
- 16 Grey M1 (NCS S 4500-N)
- 21 Black Grey (NCS S 7000-N)
- 24 Beige M1 (NCS S 2005-Y50R)
- 37 Terra Red (S 4040-Y70R)

Finish customization
(Available options: Vibia colour palette)

Diffuser: PC- Polycarbonate
Shade: Aluminum
Led support: Aluminum
Tube: Steel
Canopy: Steel

LED Colour Temperature
2700 K; 3000 K; 3500 K
CRI>90

Control
Analog: 1-10V; Push
Digital: DALI-2
Smart: Casambi

Electrical connection options

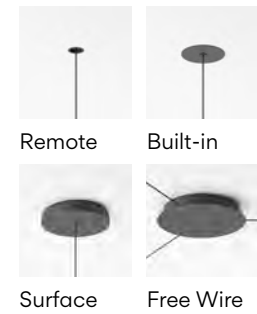

BIND related product



MULTIPLE MODELS

Set your composition to vibia.com

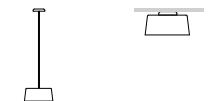
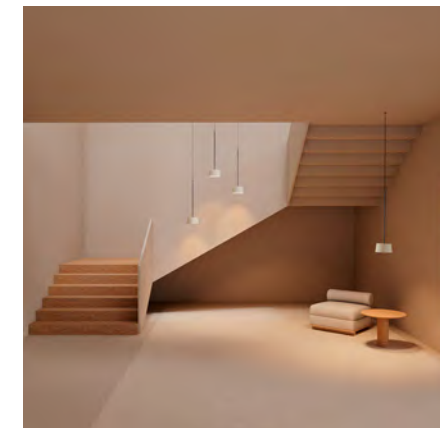
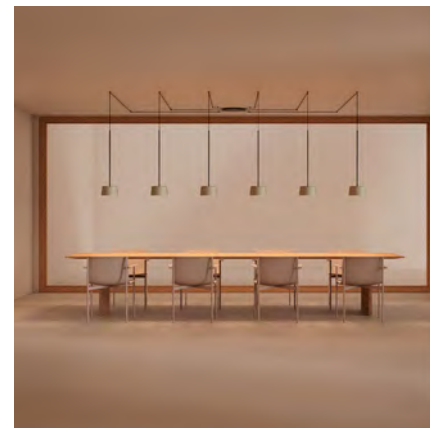

Tube



Design by Ichiro Iwasaki.

Tube is a modular pendant and ceiling system with numerous possibilities. Composed of three different sized luminaires and a black tube that extends both vertically and horizontally, it conducts light to wherever it is required, integrating within the architecture of any interior.

Tube is an innovative system of hanging lamps: a network of tubes directs the light from a single point of connection to numerous luminaires that can be freely positioned within a space. The tubes draw distinct lines across a wall, ceiling or through space, offering a graphic tool with which to design a space, as well as the opportunity to configure multiple configurations.

- 10 White (NCS S 0300-N)
- 15 Grey L2 (NCS S 2500-N)
- 16 Grey M1 (NCS S 4500-N)
- 21 Black Grey (NCS S 7000-N)
- 24 Beige M1 (NCS S 2005-Y50R)
- 37 Terra Red (S 4040-Y70R)

LED Colour Temperature
2700 K; 3000 K; 3500 K
CRI>90

Control
Analog: Push; 1-10V
Digital: DALI-2
Smart: Casambi

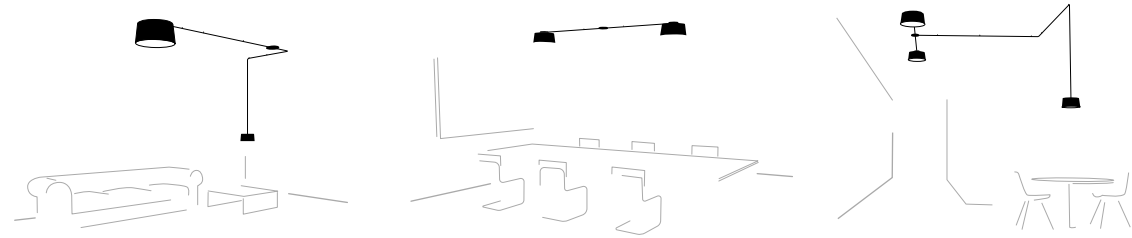

Set your composition to vibia.com



Guise



Design by Diez Office.

Crafted of precision-cut glass and embedded with a row of recessed LEDs, Guise explores the relationship between light and transparency. The light inside the glass appears invisible, while the delicately engraved surface generates a beautiful diffusion.





Crafted of borosilicate glass, a lightweight and industrial-grade material prized for its superior strength and durability, the Guise pendant can be fitted horizontally or vertically in any space. It is suspended from an invisible cable which lends a sense of weightlessness to the overall expression. Radiating with an intense glow, a special sensor offers dimming control without direct contact.

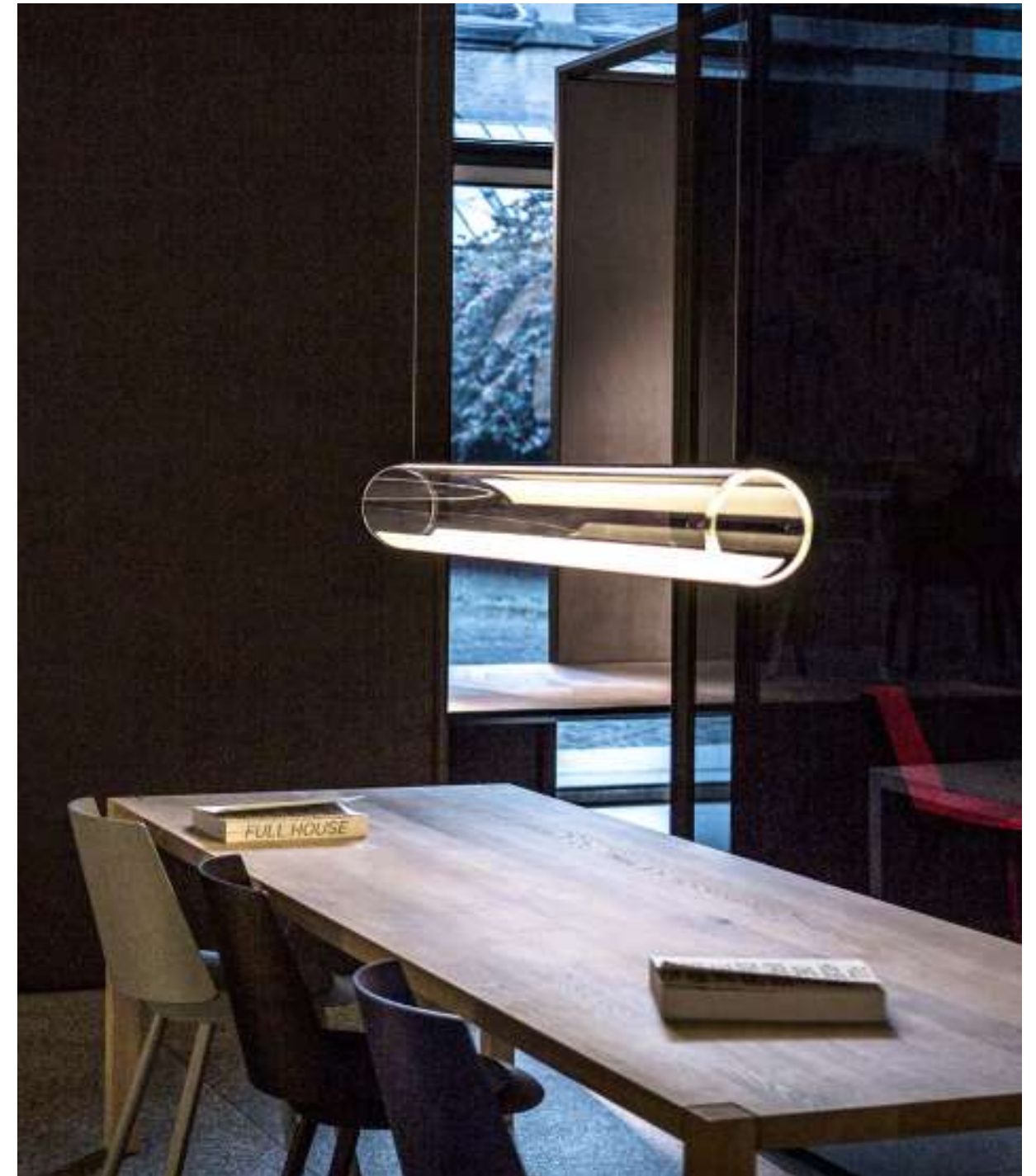

● 18 Graphite (ADAPTA RF9913WX)

Diffuser: Borosilicate glass
Body: Aluminum
LED support: Aluminum
Canopy: Steel

LED Colour Temperature

3000 K
CRI>90

Control

Analog: Push;
Sensor; 1-10V
Digital: DALI-2
Smart: Casambi

2282
Ø 25 cm



2288
Ø 40 cm

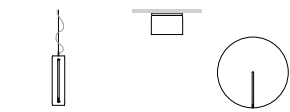

Pg 110 VOL 1 Pg 168/288 VOL 2

2277
89 cm



2270
Ø 16 cm



2272
Ø 16 cm



2272 Dimmer: optical sensor

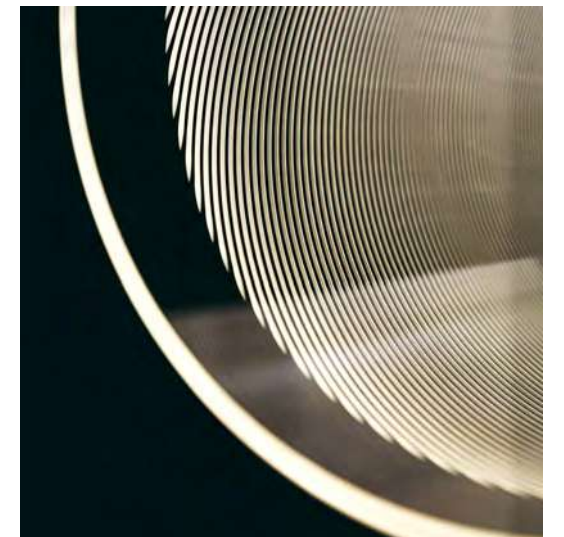
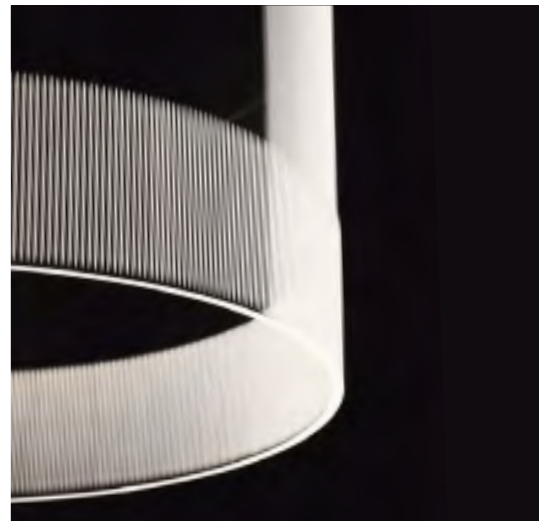

Skán



Design by Lievore, Altherr, Molina.

Skán is a sleek and unadorned fixture. It combines lean lines with soothing purity of form, adding a minimalist sensibility to any space.



Sleek and understated, the Skan pendant adds a minimalist sensibility to any space. The LED-powered design is marked by a restrained geometric profile with its elegant interplay of lean lines and gentle curves. Suspended overhead by a lean cable, its saucer-like silhouette is at once delicate and dramatic.



INDIVIDUAL MODEL

Skans sleek disc design is defined by its pure form and simple lines. The LED-powered pendant features a steel canopy and diffuser that casts a broad, bright dimmable light. Streamlined and understated, it lends a quiet elegance as a single lamp or grouping of pendants.

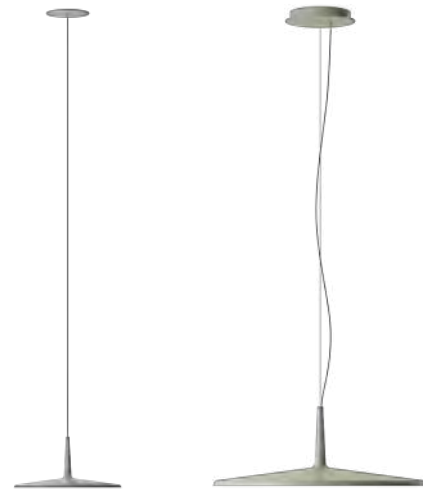

0270
Ø 30 cm

0275
Ø 60 cm

MULTIPLE MODELS

Set your composition at vibia.com

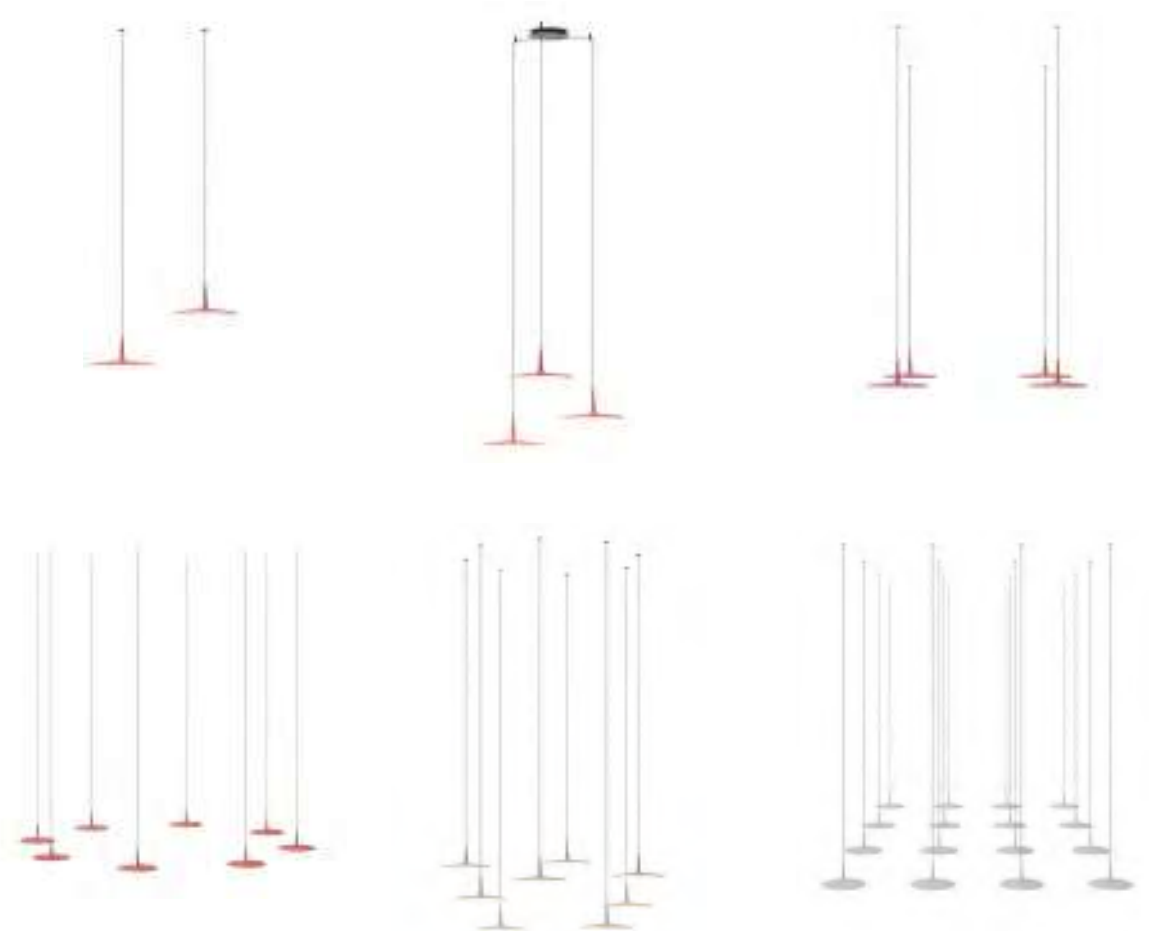

- 10 White (NCS S 0300-N)
- 11 Black (NCS S 8500-N)
- 24 Beige M1 (NCS S 2500-Y50R)
- 37 Terra Red (NCS S 4040-Y70R)
- 42 Blue M1 (NCS S 5010-B10G)
- 47 Green L1 (NCS S 4005-G80Y)

Finish customization
(Available options: Vibia colour palette)

Shade: Aluminum
Diffuser: PMMA
Canopy: Steel

LED Colour Temperature
2700 K; CRI >90
3000 K; CRI >80
3500 K; CRI >90

Control
Analog: Push; 0-10V; 1-10V
Digital: DALI-2
Smart: Casambi

Electrical connection options

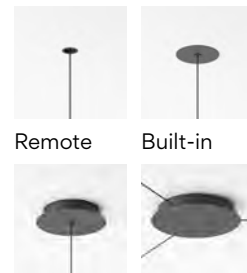

Remote Built-in
Surface Free Wire

BIND related product

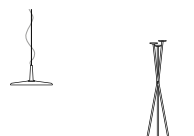
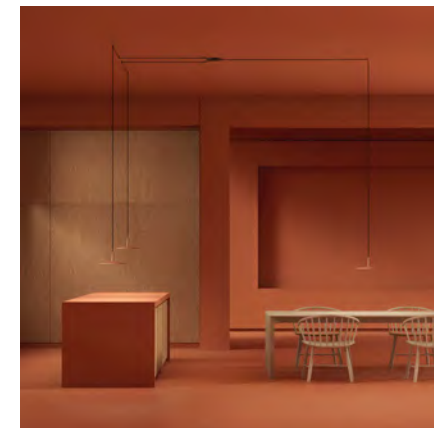

Warm



Design by Ramos & Bassols.

A contemporary take on a timeless design, Warm features a generously sized, classic drum shade with a muted colour palette that provides a refined touch.





4925 4926
 Ø 62 cm

Screen shade: Ref. 4925

- 10 White (NCS S 0300-N)

Aluminum shade: Ref. 4926.

- 10 White (NCS S 0300-N)
- 25 Beige D1 (NCS S 4005-Y50R)
- 28 Brown M1 (NCS S 4020-Y60R)
- 56 Green D1 (NCS S 7010-G30Y)

Finish customization
 (Available options: Vibia colour palette)

Diffuser: PMMA
 Canopy: Steel

LED light source

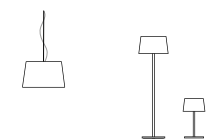

Wireflow



Design by Arik Levy.

Crafted of black, electrical cables, Volumetric's airy, three-dimensional outline lends it the feeling of being at once present and absent. The geometric volumes are tipped with LED light terminals in a contemporary take on the traditional chandelier.





Pressed-glass diffuser

Wireflow volumes for gathering spaces. Illuminate dining, living or working spaces of any scale with geometric shapes that provide a focal point without overpowering the space. Choose from multiple shapes and sizes, plus adjust lengths to suit individual tastes and project needs.

Create a personalized Wireflow pendant at vibia.com

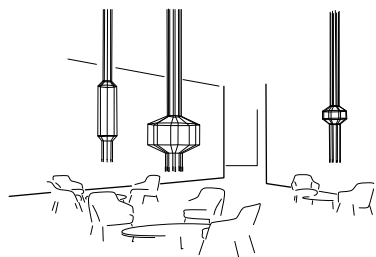

Characterised by its graphic style and simplicity of form, Wireflow traces three-dimensional geometries of steel and aluminum, which, despite their large scale, maintain a sense of weightlessness. Available in 4 and 8 diffuser versions, its distinctive volumetric aesthetic will draw the eye to specific focus points without visually overcomplicating an area.

● 04 Black (RAL 9005)

Diffuser: Pressed-glass
Body: Aluminum
Horizontal rods and Canopy: Steel

LED Colour Temperature
2700 K; 3000 K; 3500 K
CRI>90

Control
Analog: Push; 1-10V
Digital: DALI-2
Smart: Casambi

4 LEDs

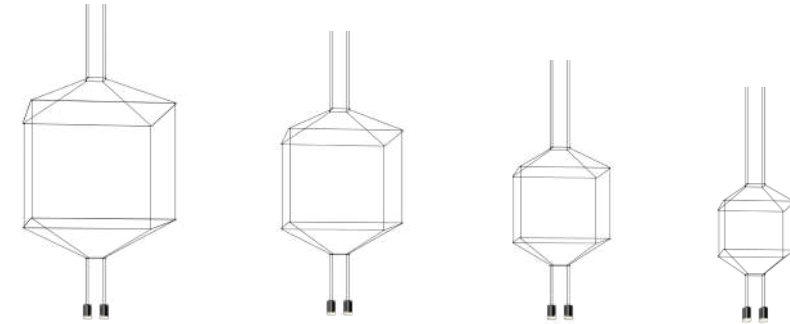

0309
100 x 100 cm

0310
80 x 80 cm

0311
64 x 64 cm

0312
50 x 50 cm

8 LEDs

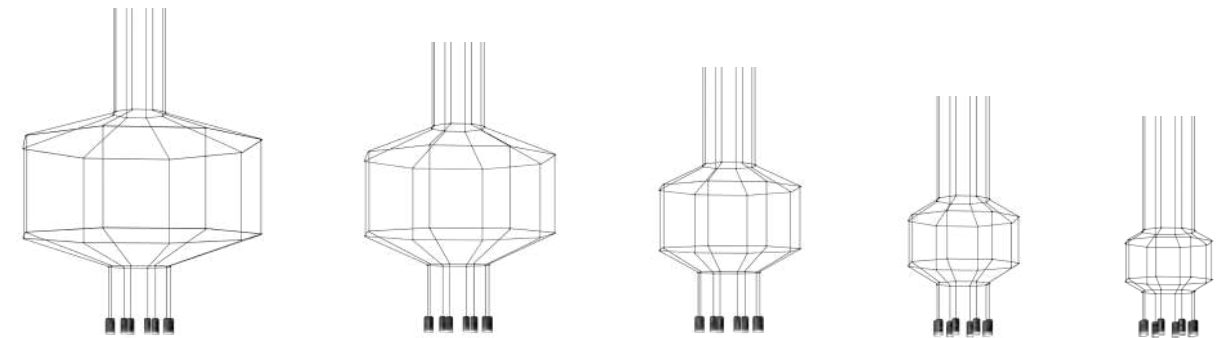

0299
150 x 150 cm

0300
120 x 120 cm

0301
89 x 89 cm

0302
70 x 70 cm

0303
55 x 55 cm

Wireflow Lineal

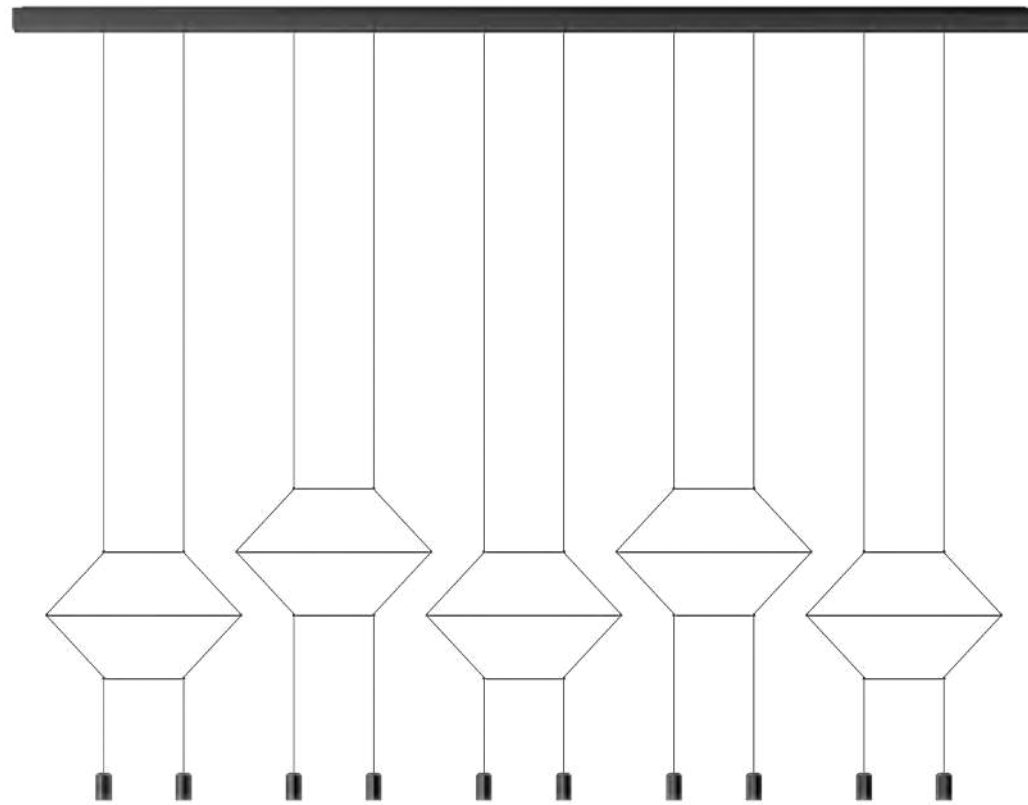

Design by Arik Levy.

Wireflow Lineal's ultra-minimalist design is balanced by a distinctive, precipitous presence that adds an intriguing accent to any room. Ideal for illuminating large spaces with high ceilings, its lean profile traces a formal silhouette in an open space with meticulous precision.



2 LEDs 0320

57 cm x max. 200 cm



6 LEDs 0338

145 cm x max. 200 cm

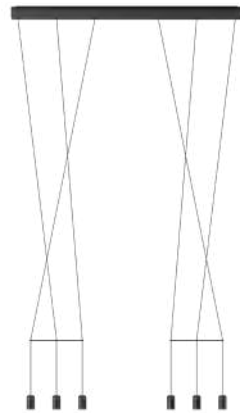

6 LEDs 0325

155 cm x max. 200 cm

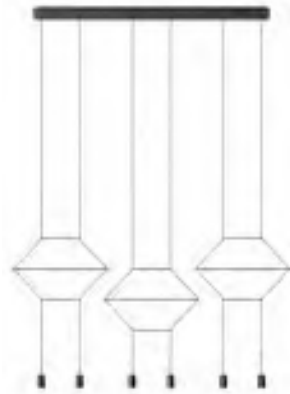

10 LEDs 0330

275 cm x max. 200 cm

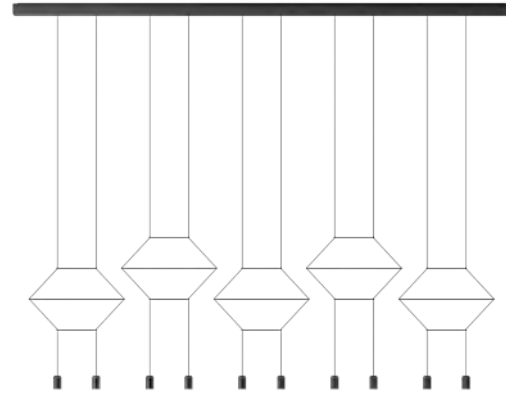

● 04 Black (RAL 9005)

Diffuser: PC- Polycarbonate
Body and canopy: Aluminum
Horizontal rods: Steel

LED Colour Temperature
2700 K; 3000 K; 3500 K
CRI>90

Control
Analog: Push; 1-10V
Digital: DALI
Smart: Casambi

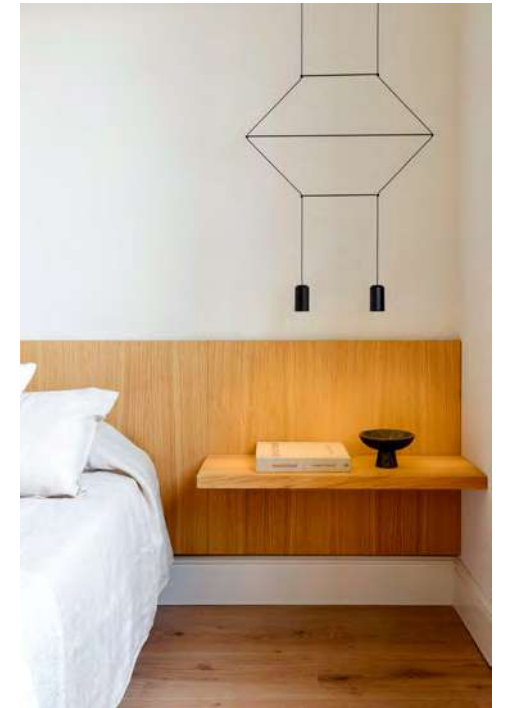
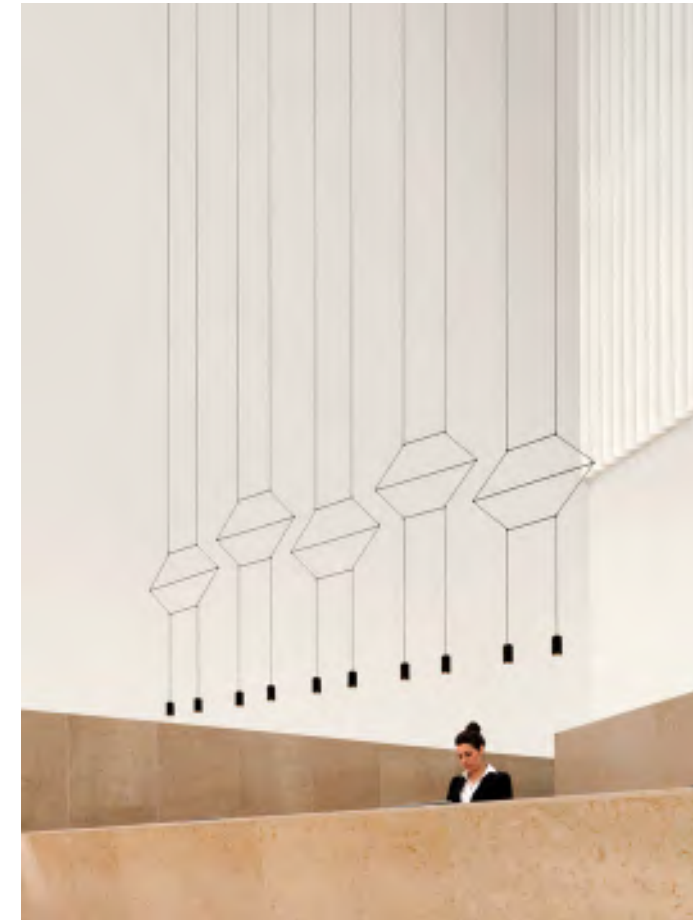

Wireflow lineal pendants for task lighting. Creative designs comprised of lineal black wires to subtly enhance a space over tables, reception desks and bars. Adjust top and bottom lengths for project needs.

Create your personalized Wireflow lineal at vibia.com



Wireflow Free



Design by Arik Levy.

True to its name, Wireflow Free adapts easily to any environment. Its cables can be directed to form unexpected visual rhythms across a wall or ceiling, or to branch out from a central point and delineate specific activity zones within a space. Free offers maximum versatility in both form and function.

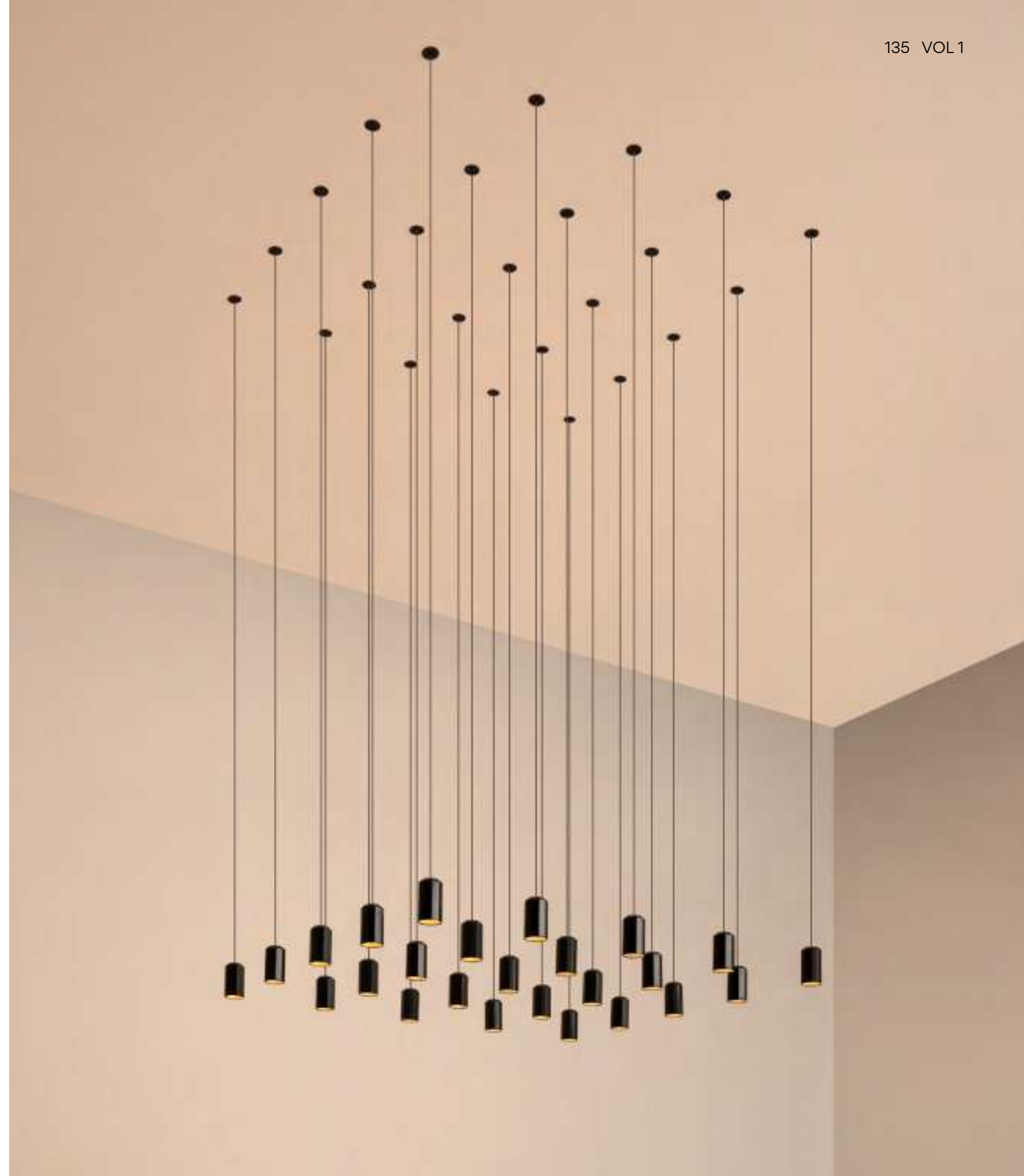



INDIVIDUAL MODEL



0347
Ø 3 x 50 x 200cm



0348
Ø 3 x 50 x 200cm

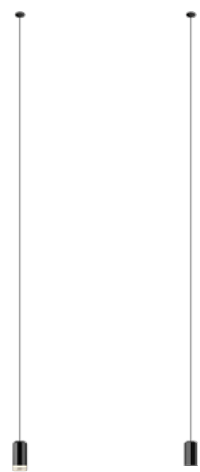

0345 0361
Ø 3 x 200cm Ø 3 x 200cm

MULTIPLE MODELS

Set your composition to vibia.com

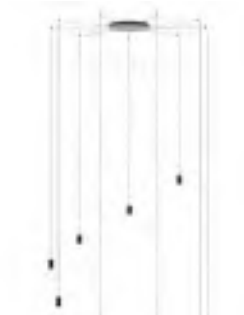
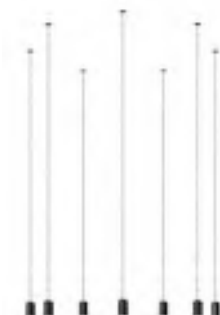
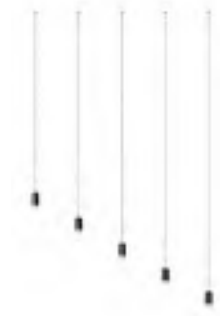

● 04 Black (RAL 9005)

Diffuser: Pressed-glass / PC- Polycarbonate
Body: Aluminum
Canopy: Steel
Ceiling supports: POM

LED Colour Temperature

2700 K; 3000 K; 3500 K
CRI>90

Control

Analog: Push; 1-10V
Digital: DALI-2
Smart: Casambi

Ref. 0345 and 0348

With pressed-glass diffuser

Ref. 0361 and 0347

Without pressed-glass diffuser,
with polycarbonate diffuser

Electrical connection options

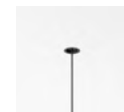

Remote



Built-in



Surface

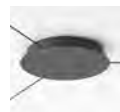

Free Wire

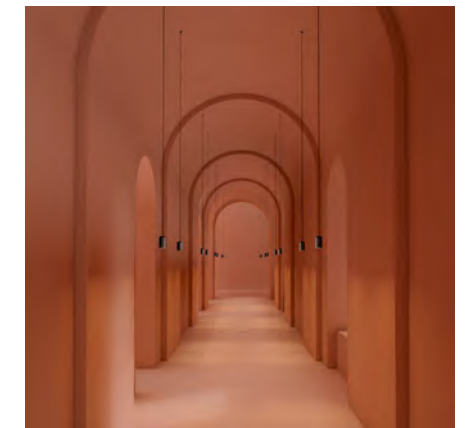
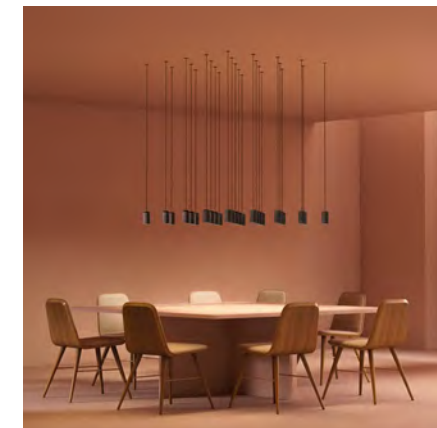
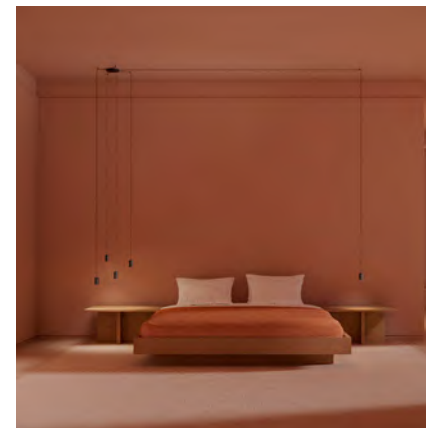

Wireflow Chandelier



Design by Arik Levy.

Wireflow Chandelier is a contemporary reimagining of the traditional fixture. Its ultramodern silhouette provides an unexpected twist, while its graceful lines echo with a sense of timeless elegance. Though substantial in size its airy outline creates a feeling of transparency.



20 LEDs 0315
120 x 279 cm

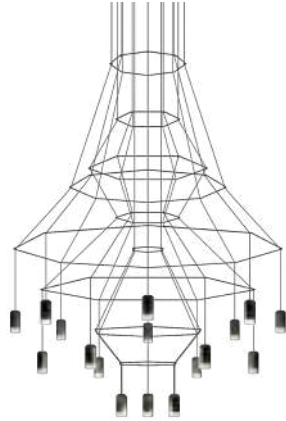

42 LEDs 0376
150 x 112 cm

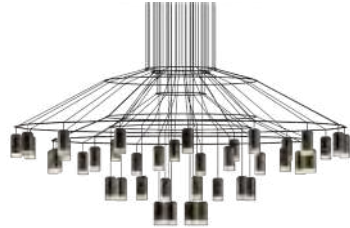

42 LEDs 0377
150 x 194 cm

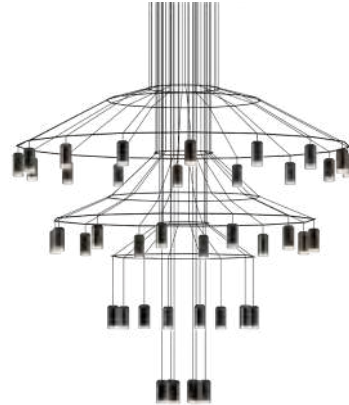

42 LEDs 0378
150 x 276 cm

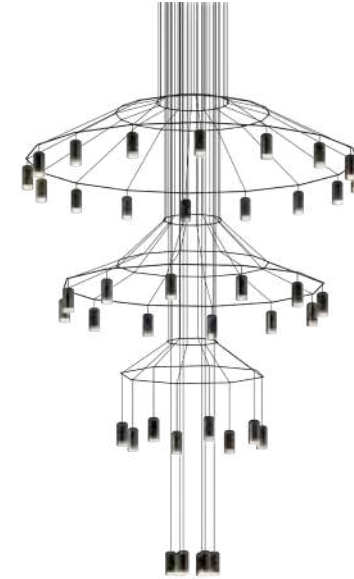

43 LEDs 0374
150 x 307 cm

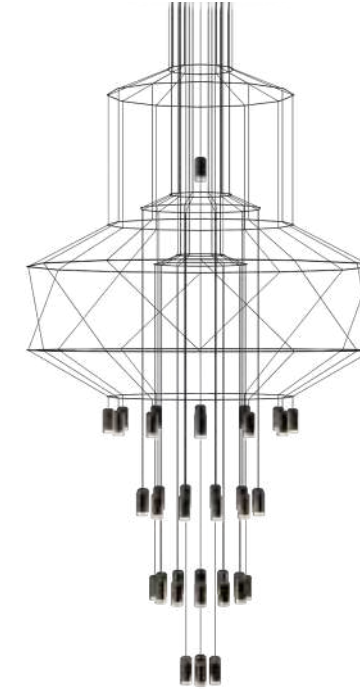

43 LEDs 0375
150 x 396 cm

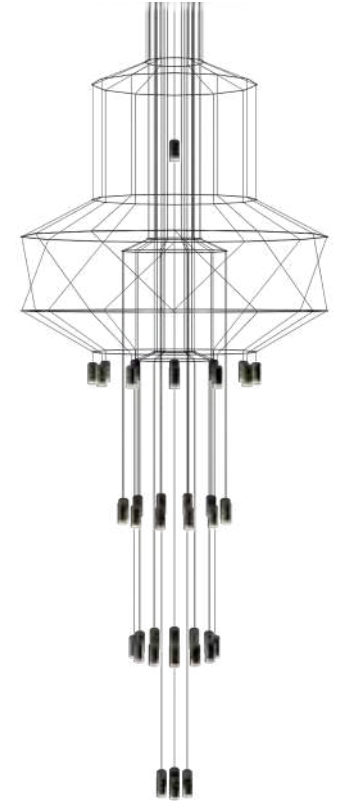

Grandeur amplified. A focal point is created with Wireflow Chandelier for large spaces with this revamp of the classic chandelier. Large scale luminaire options based on project needs with height adjustability.

Select your favorites and personalize the height at vibia.com



● 04 Black (RAL 9005)

Diffuser: Pressed-glass
Body: Aluminum
Canopy and horizontal rods: Steel

LED Colour Temperature
2700 K; 3000 K; 3500 K
CRI>90

Control
Analog: Push; 1-10V
Digital: DALI-2
Smart: Casambi

Flamingo Mini



Design by Antoni Arola.

Flamingo Mini creates multi-layered silhouettes with an avant-garde, intriguing aesthetic. This hanging lamp recalls a bird hovering overhead, bringing an intimate ambience as it casts diffuse gradations of soothing light through its translucent diffuser.





The Flamingo Mini collection pairs poetic beauty with high quality performance. Its deconstructed design separates an LED light source from layers of translucent diffusers, producing soft gradations of illumination. The diffusers are available in a range of different configurations, each LED performing like a spotlight, directed upwards or downwards to produce an ambient effect.



1575

Ø 45 cm

1580

Ø 9 cm

1585

Ø 45 cm

1590

Ø 45 cm

Option A

Option B

Option C



Three options of installation

● 11 Black (NCS S 8500-N)

Diffuser: PMMA
Rods: Stainless steel
Body: Aluminum
Canopy: ABS

LED Colour Temperature

2700 K
CRI>90

Control

Analog: Push; 1-10V
Digital: DALI-2
Smart: Casambi

Electrical connection options



Built-in

Surface





Flamingo



Design by Antoni Arola.

Displaying the elegant poise of the bird that inspired it, Flamingo projects a feeling of weightlessness hovering overhead. The deconstructed design separates the LED light source from its translucent shades, producing gradations of diffuse illumination.





1510
Ø 70 cm



1527
Ø 90 cm



1530
Ø 90 cm



1540
Ø 70 cm



1550
Ø 90 cm



1560
Ø 90 cm



1570
Ø 90 cm



- 18 Graphite (RAL 7016)
- 20 Gold (Gold)
- 67 Copper (Copper)
- 93 White (RAL 9016)

Diffuser: PMMA
 Body: Aluminum
 Canopy and rods: Steel

LED Colour Temperature
 2700 K; 3500 K
 CRI>90

Control
 Analog: Push; 1-10V
 Digital: DALI-2
 Smart: Casambi



Cosmos

Design by Lievore, Altherr, Molina.

Design and light become one with the Cosmos collection. Flattened spheres suspended from slim cables create a cluster of pendant lights like a constellation of stars.







The minimalist, lacquered discs floating in space, their simple, sculptural curves and muted finishes, transmit a tranquil sensibility. LEDs are embedded within the opaque diffusers, unifying design and light source to generate a warm, indirect glow.

- 10 White (NCS S 0300-N)
- 14 Chocolate (RAL 8019)
- 58 Off-white (NCS S 2005-Y20R)
- 62 Green (Pantone 5645)

Diffuser: PC-Polycarbonate
Canopy: Steel
Body: PU - Polyurethane

LED Colour Temperature

2700 K; CRI >90
3000 K; CRI >80

Control

Analog: On/ Off; Push; 1-10V
Digital: DALI-2
Smart: Casambi



Match



Design by Jordi Vilardell & Meritxell Vidal.

Based on the principle of co-creation, Match is a lighting collection that can be fully customised virtually. Characterised by unlimited configurations, Match's kinetic clusters exude a textured, sculptural presence.

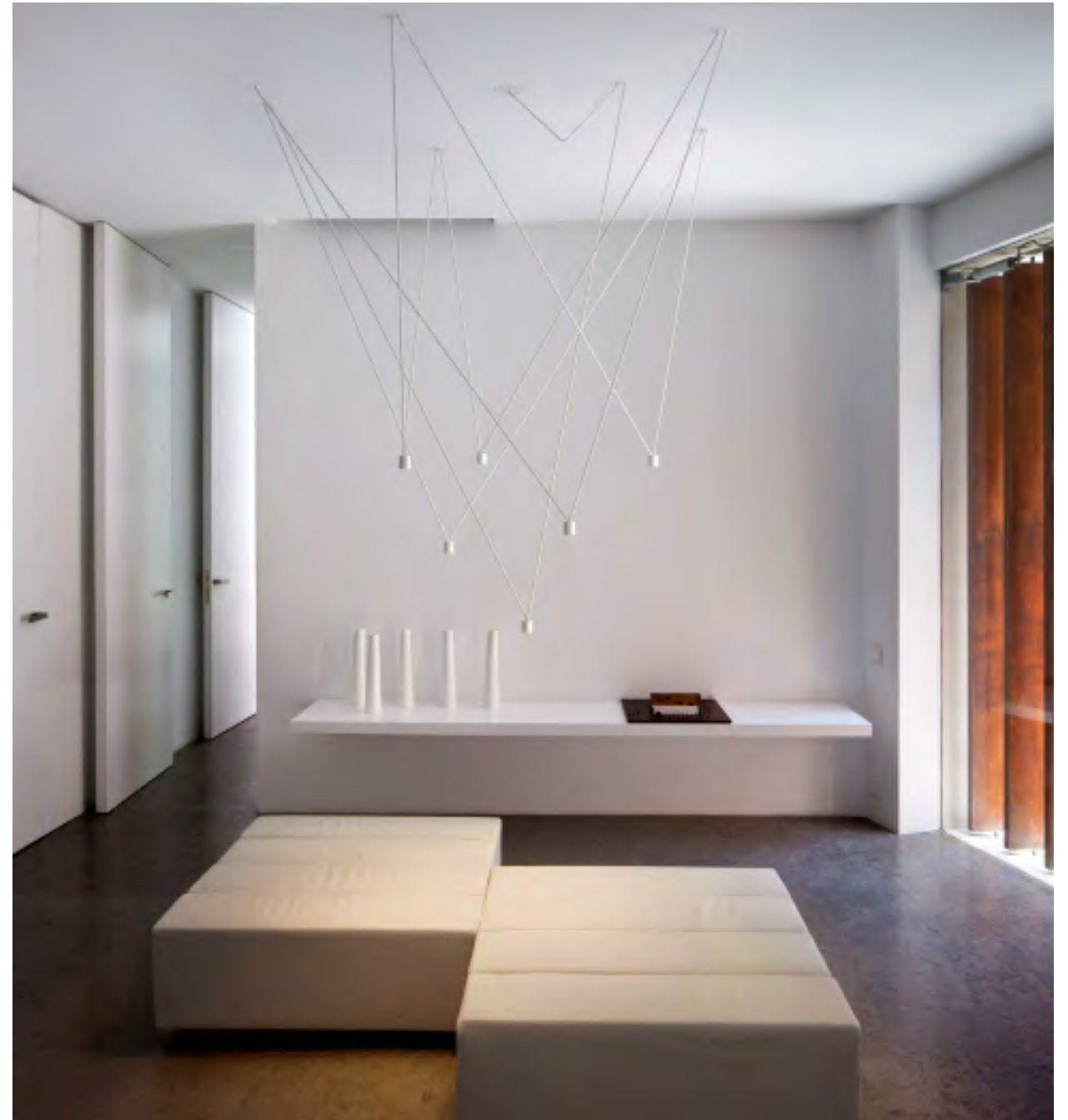

Match is a unique pendant collection constructed from sleek aluminum rods finished in matt lacquered white or matt lacquered graphite and equipped with LED light terminals. Fully customisable, it is based on the concept of co-creation, taking on myriad forms to suit any space: from tight, concentrated clusters to sprawling configurations that span a larger area.

- 03 White (RAL 9016)
- 18 Graphite (RAL 7016)

Head: Aluminum
Rods: Steel
Canopy Plate: Steel

LED Colour Temperature
2700 K; 3000 K; 3500 K
CRI>80

Control

Analog: Push; 1-10V
Digital: DALI-2
Smart: Casambi

Personalization options available

Configuration layout at vibia.com
Request more information

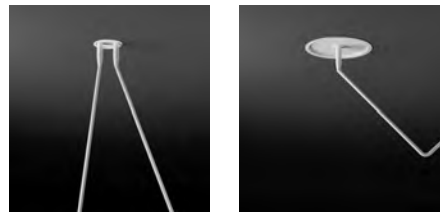

Built-in installation.

Electrical connection finials: the minimum height is 10 cm and the dimension of the cut-out is 10,5 cm.

Nodes: the minimum height is 12 cm and the dimension of the cut-out is 4,5 cm.



Palma



Design by Antoni Arola.

The interior ambience takes on a life of its own with the possibility of integrating plants with the lighting compositions. Palma connects light and vegetation as in the natural landscape.



● 18 Graphite (ADAPTA RF 9913 WX)

Diffuser: Blown-glass
Profile: Aluminum
Planter: PMMA

LED Colour Temperature

2700 K
CRI>90

Control

Analog: Push; 1-10V
Digital: DALI-2
Smart: Casambi

3720

Ø 25 cm



3724

Ø 25 cm



3726

Ø 25 cm



3728

Ø 25 cm



3730

Ø 25 cm

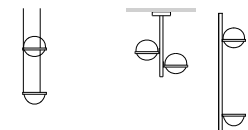

Pg 170 VOL 1 Pg 116/256 VOL 2



The floating effect is attained through its multiple configurations, the almost imperceptible suspension, a unique cable system and the hoops that wrap the spheres. Its capacity to create ambience increases with additional fixtures like a luminous hanging garden.

● 18 Graphite (ADAPTA RF 9913 WX)

Diffuser: Blown-glass
Profile: Aluminum
Planter: PMMA

LED Colour Temperature

2700 K
CRI>90

Control

Analog: Push; 1-10V
Digital: DALI-2
Smart: Casambi

3734

150 cm

3735

150 cm

3736

195 cm

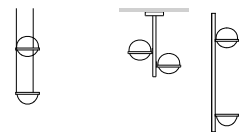
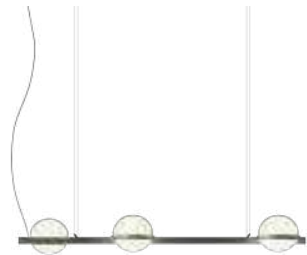

Pg 170 VOL 1 Pg 116/256 VOL 2



Bigger



Design by La Invisible.

Bigger serves as statement lighting without overbearing the space it occupies, radiating with profuse light which cascades down from the ceiling, its impressive scale bringing the space to life.



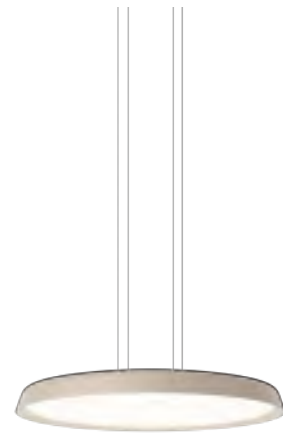

3920
Ø 80 cm
7729 lm

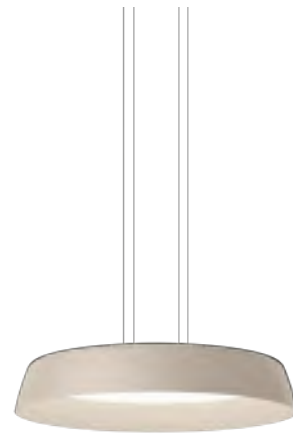

3925
Ø 84 cm
7729 lm



3930
Ø 103 cm
14301 lm



3935
Ø 107 cm
14301 lm



- 23 Beige L1 (NCS S 0502-Y50R)
- 24 Beige M1 (NCS S 2005-Y50R)
- 37 Terra Red (NCS S 4040-Y70R)
- 53 Green M1 (NCS S 6005-G80Y)

Body: Aluminum
Shade: Aluminum
Diffuser: PC- Polycarbonate

LED Colour Temperature
2700 K; 3500 K
Tunable White (2200 K-4000 K)
CRI>90

Control
Analog: Push; 1-10V
Digital: DALI-2
Smart: Casambi

Vibia's general lighting, spot accent and downlight luminaires include the option of tunable white. Combining these zenithal tunable white lights with the rest of the diffused and indirect lighting effects of Vibia's portfolio, you can design the perfect scene for every moment and use.

Tunable White (2200K - 4000K)
Tunable white lighting option allows for comprehensive temperature regulation depending on the atmosphere of every scene.

Static White 2700K; 3500K
You can select the static white option that fits best with the desired ambience.



Contact Vibia Support Service at vibia.com for any kind of assistance or recommendation when designing an atmosphere of wellbeing, or if you require support with control system approach.

Rhythm

Horizontal



Design by Arik Levy.

Minimalist in form yet simultaneously complex, Rhythm features slender light modules of varying lengths, each fitted with an LED, that can be arranged in endless configurations. Fluid and flowing or angular and anarchic, the collection offers total freedom of composition.



Wood

The collection includes the option of a natural wood in White oak or Walnut. Reflected in its textured surface, warm light bathes the space, producing a rich and restorative atmosphere.

- 82 White oak
- 83 American walnut

Stick: Wood
Spacers: Aluminum
Diffuser: PC-Polycarbonate
Canopy: Steel

LED Colour Temperature
2700 K; 3500 K
CRI>90

Control
Analog: 1-10V
Digital: DALI-2
Smart: Casambi

Electrical connection options



Built-in Surface

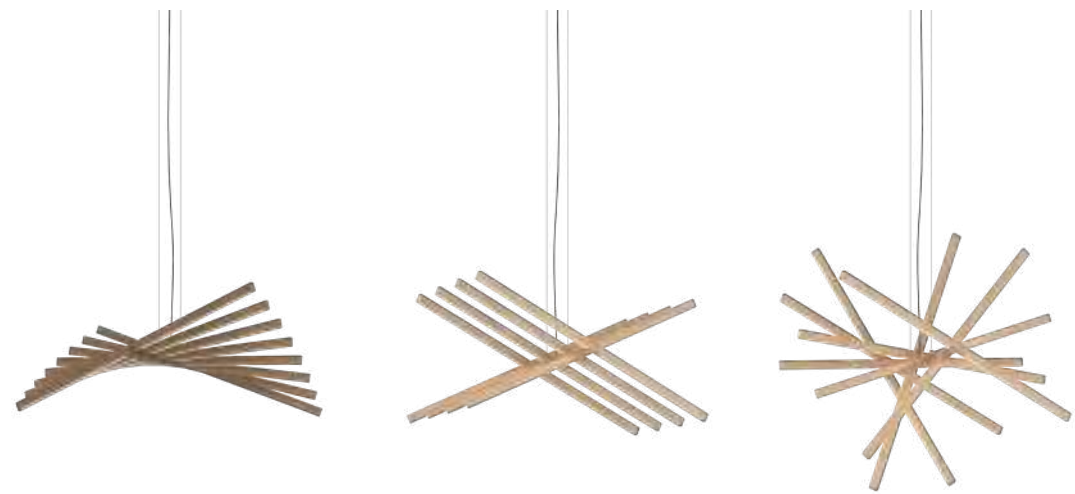

Stick 87 cm

2155

49 x 87 cm

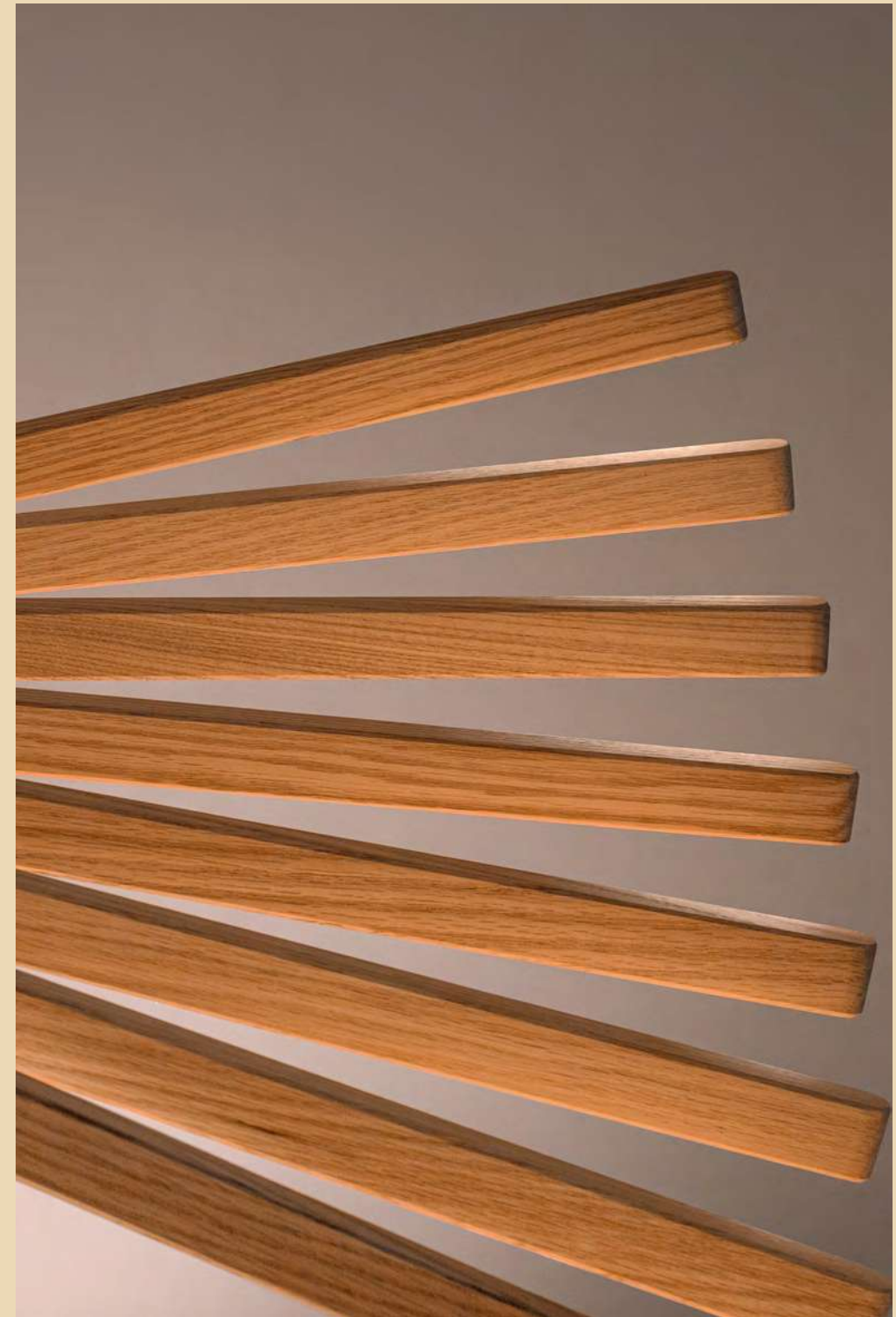

Basic

Its unique rotation system allows the light sticks to move along a horizontal axis, positioned in any direction to provide ambient downward illumination from above.

- 14 Chocolate (RAL 8019)
- 58 Off-white (RAL D2 1109005)

Stick: PA- Polyamide
 Diffuser: PC- Polycarbonate
 Canopy: Steel

LED Colour Temperature
 2700 K; 3500 K
 CRI>90

Control
 Analog: 1-10V
 Digital: DALI-2
 Smart: Casambi

— **Electrical connection options**



Stick 47 cm



2110
45 x 47 cm

2111
93 x 47 cm

2112
141 x 47 cm

2113
189 x 47 cm

Stick 87 cm



2120
63 x 87 cm

2121
131 x 87 cm

2122
199 x 87 cm



Rhythm Vertical



Design by Arik Levy.

Evoking the mood of Zen minimalism, Rhythm features slender light modules of varying lengths, each fitted with an LED module, that can be arranged in endless configurations.



Wood

The collection includes the option of a natural wood in White oak or Walnut. Reflected in its textured surface, warm light bathes the space, producing a rich and restorative atmosphere.

- 82 White oak
- 83 American walnut

Stick: Wood
Spacers: Aluminum
Diffuser: PC-Polycarbonate
Canopy: Steel

LED Colour Temperature

2700 K; 3500 K
CRI>90

Control

Analog: 1-10V
Digital: DALI-2
Smart: Casambi

Electrical connection options



Built-in Surface

Stick 87 cm

2165
87 x 52,5 cm



2167
87 x 81 cm





Basic

A luminous sculpture suspended in space, Rhythm can be suspended vertically to provide ambient uplighting.

- 14 Chocolate (RAL 8019)
- 58 Off-white (RAL D2 1109005)

Stick: PA- Polyamide
 Diffuser: PC-Polycarbonate
 Canopy: Steel

LED Colour Temperature
 2700 K; 3500 K
 CRI>90

Control
 Analog: 1-10V
 Digital: DALI-2
 Smart: Casambi

Electrical connection options



Built-in Surface

2141
 47 x 108 cm

2142
 47 x 163,5 cm

2143
 47 x 219 cm

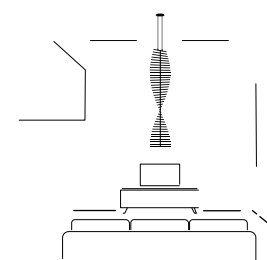
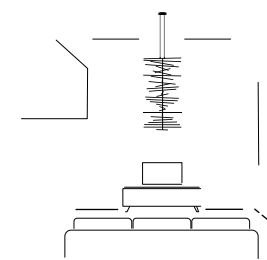
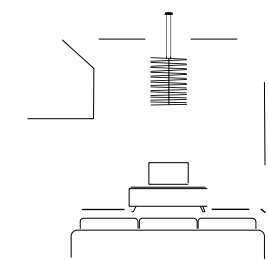

Mayfair



Design by Diego Fortunato.

A modern reimagining of the traditional 19th-century bouillotte lamp, the Mayfair collection is a statement in contemporary design. Perfectly proportioned, its luminaire casts a pool of diffuse, downward light to create an intimate lighting effect.





Featuring a steel or methacrylate diffuser, the LED-powered pendant lamp is distinguished by its timeless style and sleek silhouette. Available in a range of striking colours, it casts a warm ambient glow that's ideal for relaxed interior lighting.



INDIVIDUAL MODEL

PMMA shade: Refs. 5520

- 07 Graphite and green (RAL 7016 and RAL 6026)
- 08 Graphite and orange (RAL 7016 and RAL 2009)

Steel shade: Refs. 5525

- 20 Gold (Gold)
- 67 Copper (Copper)

- 18 Graphite (RAL 7016)
- 23 Warm White (NCS S 0502-Y50R)
- 25 Beige D1 (NCS S 4005-Y50R)
- 38 Terra Dark (NCS S 5040-Y70R)
- 47 Green L1 (NCS S 4005-G80Y)

Finish customization
(Available options: Vibia colour palette)

Diffuser: PC-Polycarbonate
Tube and canopy: Steel

LED Colour Temperature

LED 2700 K
CRI >90

Control

Individual model
Analog: Push; 1-10V
Digital: DALI-2
Smart: Casambi

Electrical connection options



Remote Built-in

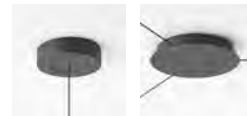

Surface Free Wire

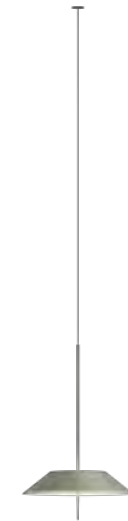

5525 5520
Ø 30 cm Ø 30 cm

MULTIPLE MODELS

Set your composition to vibia.com

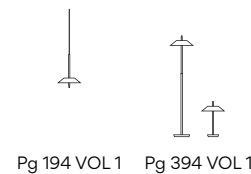

Pg 194 VOL1 Pg 394 VOL1

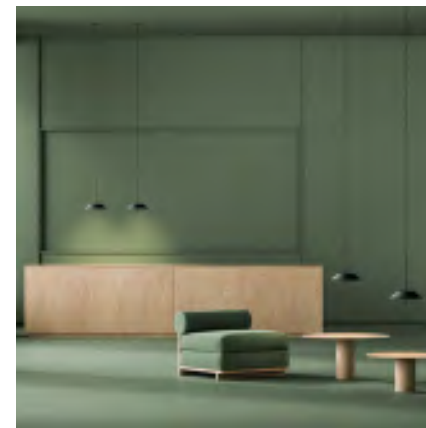

Algorithm Free

Design by Toan Nguyen.

Like a cloud of frozen rain, this collection brings together beauty and geometry. Each unique grouping of globes defines areas of interior space, underlining their multiple uses while becoming a single aesthetic element.





INDIVIDUAL MODEL



O820
Ø 9 cm

MULTIPLE MODELS

Set your composition to vibia.com

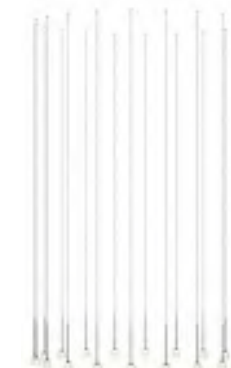

● 18 Graphite (ADAPTA RF 9913 WX)

Sphere: Blown-glass
Diffuser: PC- Polycarbonate
Glass fastening: Aluminum
Canopy: Steel
Pendant structure: Steel
LED support: Aluminum

LED Colour Temperature
2700 K; 3500 K
CRI >90

Control
Analog: Push; 1-10V
Digital: DALI-2
Smart: Casambi

Electrical connection options

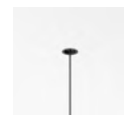

Remote



Built-in



Surface

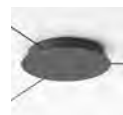

Free Wire



Algorithm Grid



Design by Toan Nguyen.

Like a cloud of frozen rain, this collection brings together beauty and geometry. Mathematical order provides a magical harmony with an astonishing range of permutations and compositions. Can be customized to suit any space.



Algorithm resembles a sparkling constellation of illuminated drops that appear to float in mid-air. Evoking a mood that's equal parts mathematical and magical, the pendant is anchored to the ceiling from a tubular steel lattice. Sleek tensile cables are studded with glowing, handblown glass orbs powered by LEDs and suspended at different heights. Fully customisable, each unique grouping of globes defines areas of interior space, underlining their multiple uses while becoming a single aesthetic element.

● 18 Graphite (ADAPTA RF 9913 WX)

Sphere: Blown-glass
Diffuser: PC- Polycarbonate
Glass fastening: Aluminum
Canopy: Steel
Pendant structure: Steel
LED support: Aluminum

LED Colour Temperature

2700 K; 3500 K
CRI >90

Control

Individual model
Analog: Push; 1-10V
Digital: DALI-2
Smart: Casambi

Create your personalized Algorithm at vibia.com



0825 0827* 10 LEDs 75 x 85 cm



0830 0832* 6 LEDs 123 x 25 cm
0835 0837* 10 LEDs 214 x 25 cm

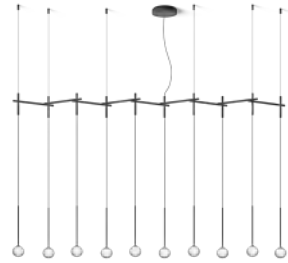

0840 0842* 14 LEDs 306 x 25 cm
0845 0847* 14 LEDs 183 x 34 cm
0850 0852* 29 LEDs 399 x 34 cm

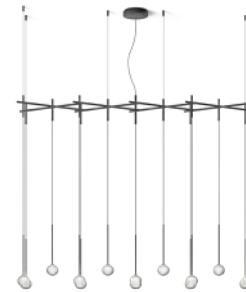

0860 0862* 13 LEDs 110 x 110 cm
0865 0867* 25 LEDs 160 x 160 cm



0870 0872* 15 LEDs 110 x 60 cm
0875 0877* 24 LEDs 185 x 60 cm

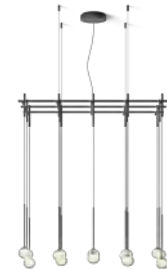

*Built-in canopy



Slim



Design by Jordi Vilardell.

Streamlined and refined, Slim serves as a sleek punctuation mark.



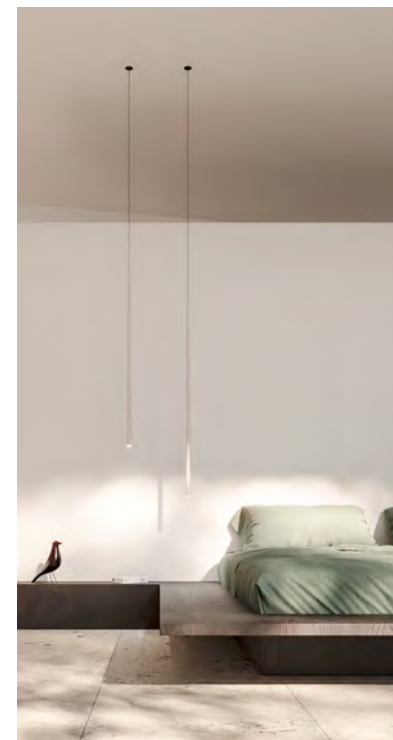

Distinguished by long, slender strands suspended from fibre cords, Slim draws the eye upwards like drops of light falling from the sky. Crafted of patterned glass diffusers, it lends a candlelit ambience that bathes a space in a soft pool of light thanks to its LED fittings.

INDIVIDUAL MODEL



0920
Ø ,6 cm

MULTIPLE MODELS

Set your composition to vibia.com

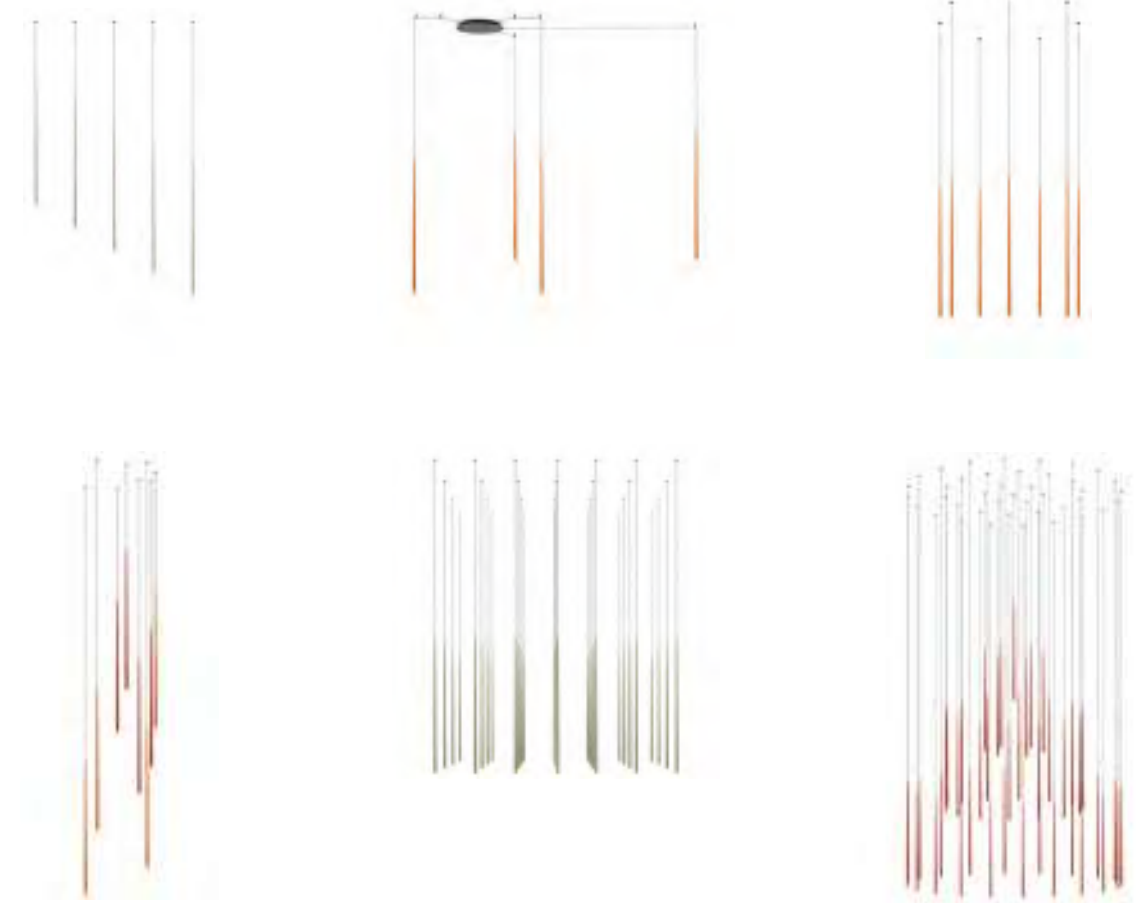
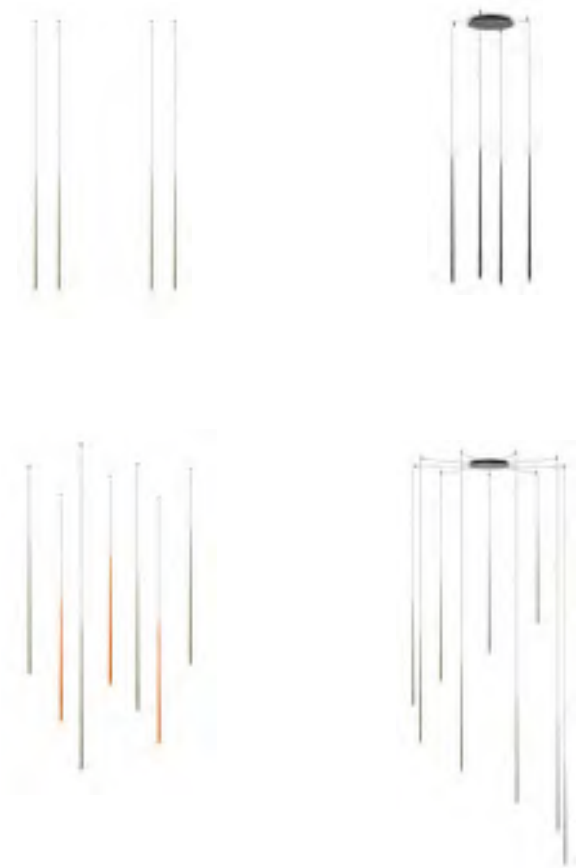

- 10 White (NCS S 0300-N)
- 11 Black (NCS S 8500-N)
- 24 Beige M1 (NCS S 2005-Y50R)
- 37 Terra Red (NCS S 4040-Y70R)
- 47 Green L1 (NCS S 4005-G80Y)
- 68 Ocre (NCS S 3050-Y30R)

LED Colour Temperature

- 2700 K; CRI >90
- 3000 K; CRI >80
- 3500 K; CRI >90

Control

- Analog: On/ Off; Push; 1-10V
- Digital: DALI-2
- Smart: Casambi

Electrical connection options

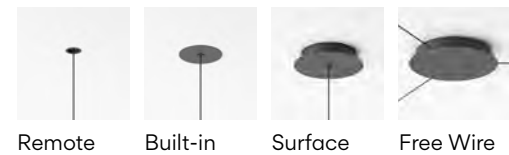

BIND related product



Finish customization
(Available options: Vibia colour palette)

Diffuser: Glass
Body: FB- Fiberglass
Canopy: Steel

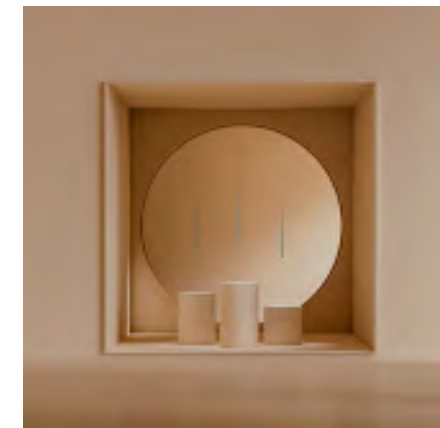
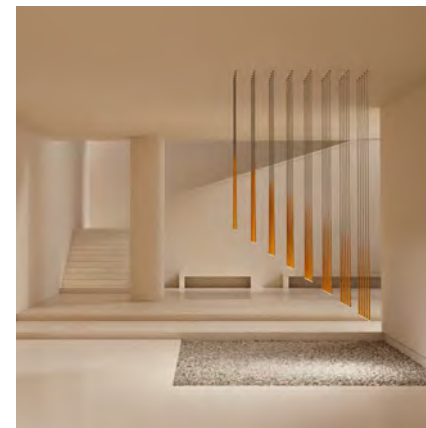

Halo



Design by Martín Azúa.

A seamless merging of light and matter, Halo lends the effect of light floating in air. Powered by LED bulbs that remain invisible within their opalized, linear moulds, the light flows freely from its source.

2340
2 units

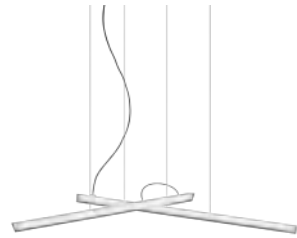

2341
3 units



● 03 White (RAL 9016)

Diffuser: PMMA
Canopy: Steel



LED Colour Temperature

2700 K; 3000 K
CRI >90

Control

Analog: 1-10V
Digital: DALI-2
Smart: Casambi

Electrical connection options



Remote Surface

2342
6 units

2343
9 units

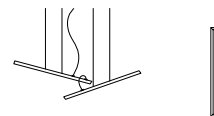
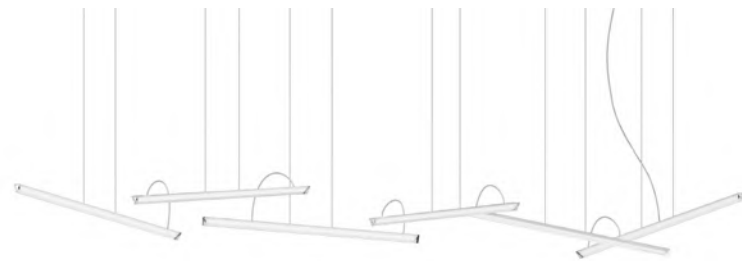

● 03 White (RAL 9016)

Diffuser: PMMA
Canopy: Steel
LED support: Aluminum

LED Colour Temperature

2700 K; 3000 K
CRI >90

Control

Analog: 1-10V
Digital: DALI-2
Smart: Casambi

Surface mounted

2330

Ø 55,5 cm



2331

2 units

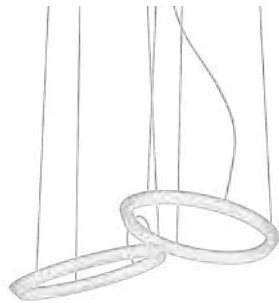

2332

3 units



2333

5 units

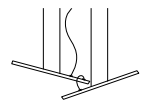
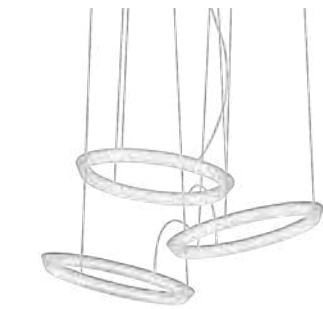

Halo Jewel

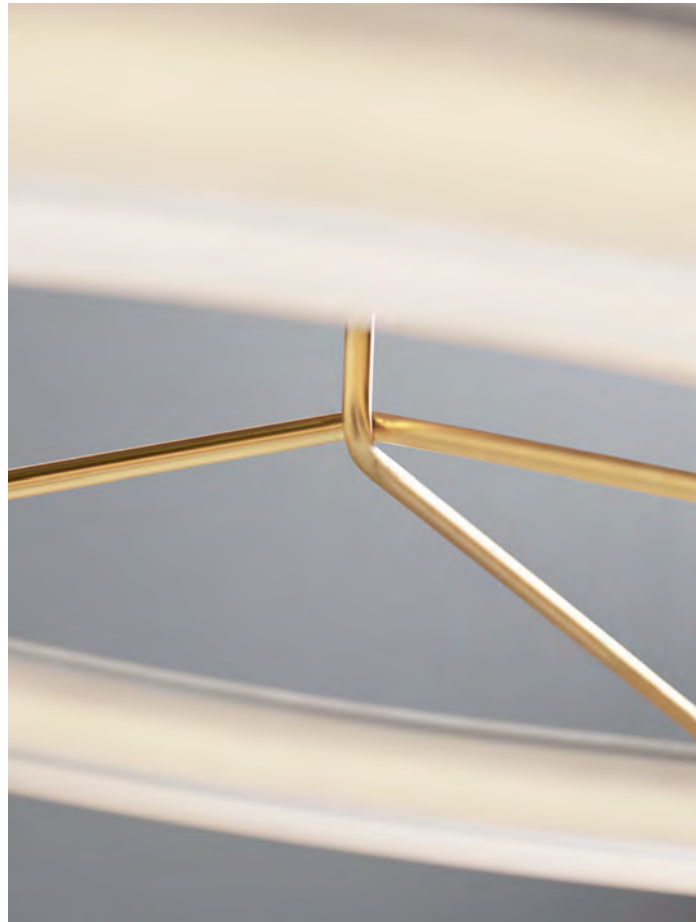

Design by Martín Azúa.

Subtle light floating in the air and delicately suspended by a perfectly crafted steel structure. Light and matter in one.



INDIVIDUAL MODEL



- 11 Black (NCS S 8500-N)
- 20 Gold (Gold)

Canopy: Steel
 Pendant structure: Steel
 Diffuser: Methacrylate
 LED support: Aluminum

LED Colour Temperature
 2700 K; 3000 K
 CRI >90

Control
 Analog: 1-10V
 Digital: DALI-2
 Smart: Casambi

Electrical connection options

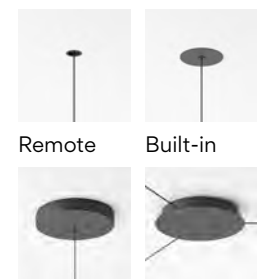

Remote

Built-in

Surface

Free Wire

MULTIPLE MODELS

Set your composition at vibia.com



INDIVIDUAL MODEL

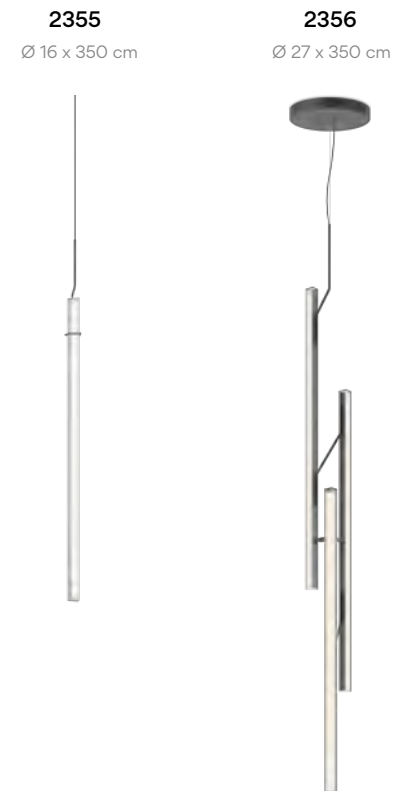

MULTIPLE MODELS

Set your composition at vibia.com

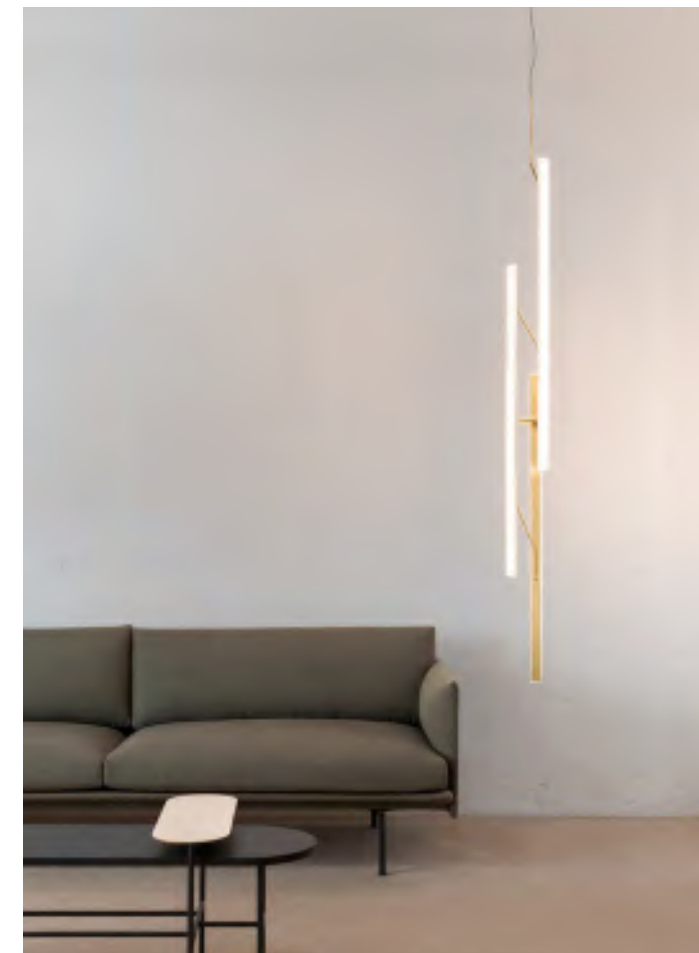
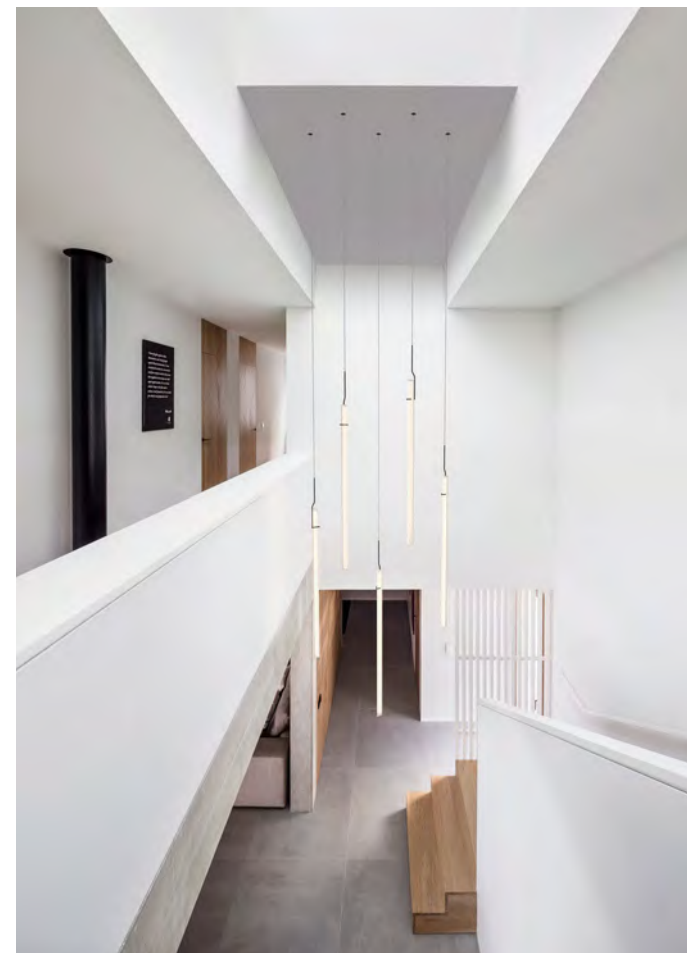

- 11 Black (NCS S 8500-N)
- 20 Gold (Gold)

Canopy: Steel
 Pendant structure: Steel
 Diffuser: Methacrylate
 LED support: Aluminum

LED Colour Temperature
 2700 K; 3000 K
 CRI >90

Control
 Analog: 1-10V
 Digital: DALI-2
 Smart: Casambi

Ref. 2355.
Electrical connection options

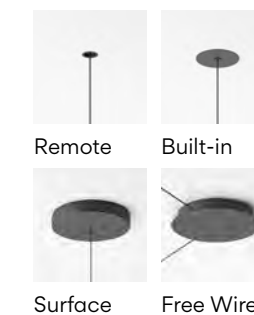

Wind

Design by Jordi Vilardell.

A perfect marriage of technology and tradition. Wind's drum shade is made of fibreglass, an innovative webbed texture and pattern that elevates the visual contribution of this timeless silhouette.



- 27 Sand (NCS S 1505-Y50R)
- 53 Green M1 (NCS S 6005-G80Y)
- 61 Ocre Red (NCS S 3050-Y60R)

Shade: FB- Fiberglass
 Canopy: Steel
 Lid: Steel
 Diffuser: PMMA

LED Colour Temperature
 2700 K
 CRI >90

Control
 Analog: On/ Off

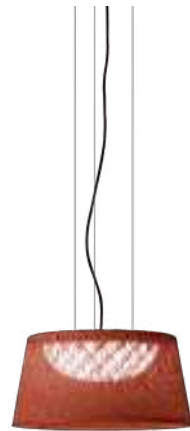

4072
 Ø 60 cm



4077
 Ø 60 cm



4078
 Ø 120 cm

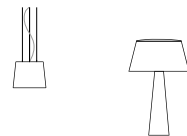

Pg 230 VOL 1 Pg 422 VOL 2
 Pg 422 VOL 2



Tempo



Design by Lievore Altherr.

The Tempo collection reclaims our collective memory of light, distilling lighting archetypes to their most basic forms. Vibia presents three designs in two sizes: the disc, the diamond and the milk glass oval - all inspired by the interplay of opacity, translucence and transparency.





The Tempo pendant lamp collection integrates perfectly into all types of spaces and contemporary interior design projects. Suspended from the ceiling by a slim cable, its blown glass diffusers offer subtle nuances of transparency and translucency.



INDIVIDUAL MODEL

5776
Ø 40 cm



5770
Ø 25 cm



5778
Ø 24 cm



5772
Ø 13 cm



5780
Ø 34,5 cm



5774
Ø 20,5 cm

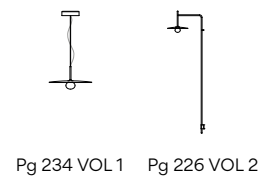

MULTIPLE MODELS

Set your composition at vibia.com



The classic bistrot globe has evolved with an oval organic shape with a gradated lighting that crosses the spectrum from transparency to translucence. The opaline diamond shade illuminates with a diffused light of superior quality. The model with the reflector plate converts the bulb into a small brilliant bubble that radiates light.

- 18 Graphite (ADAPTA RF 9913 WX)
- 37 Terra Red (NCS S 4040-Y70R)
- 58 Cream (RAL 7044)
- 62 Green (NCS S 3010-G20Y)

Diffuser: Blown-glass
Canopy: Steel
LED support: Aluminum
Shade: Aluminum

LED Colour Temperature
2700 K
CRI >90

Control
Analog: Push; 1-10V
Digital: DALI-2
Smart: Casambi

Electrical connection options

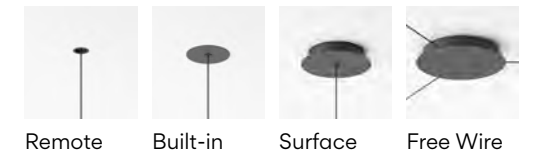

BIND related product



Bind

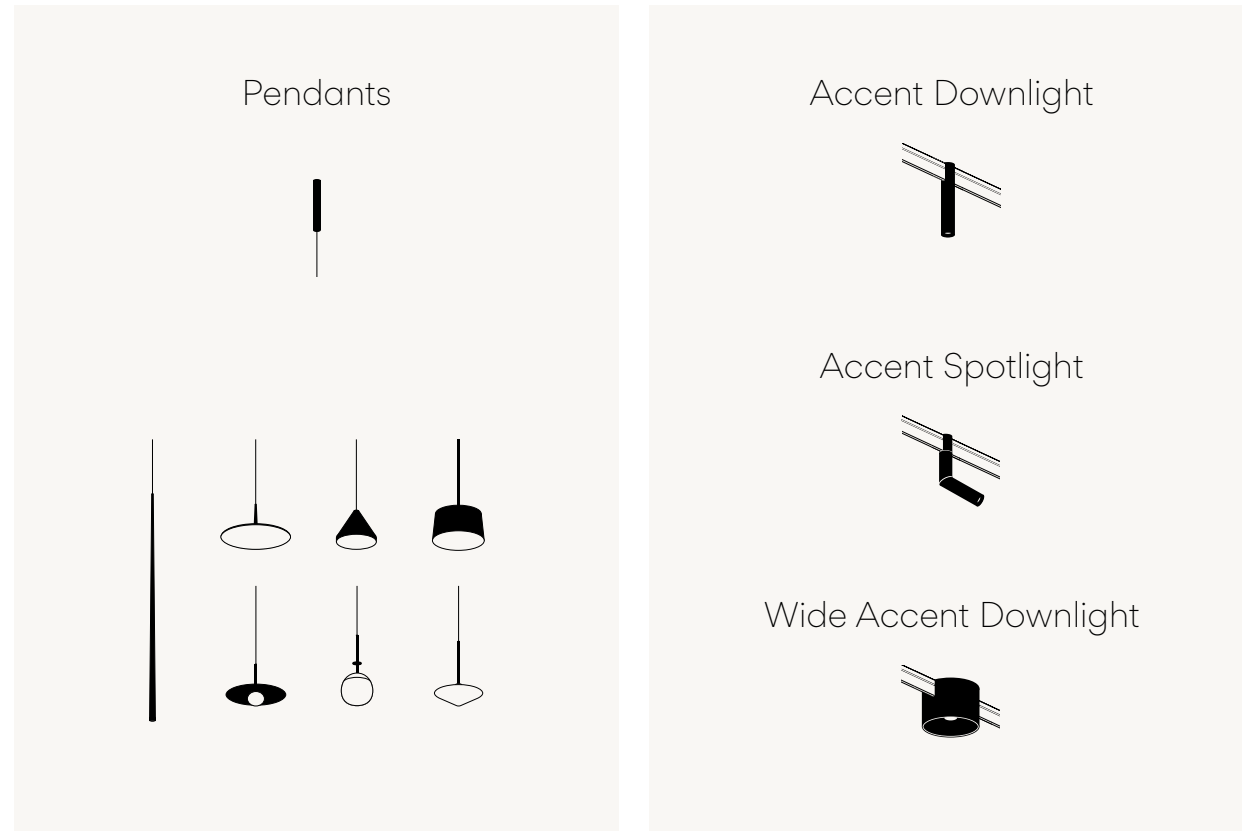

Design by Martín Azúa.

Bind is a hybrid lighting system designed to create multiple atmospheres to suit a range of spaces, uses and moods. The connective quality, ease of installation and versatility of this fully modular system guarantees a harmonious balance between technical and decorative lighting, promising new holistic lighting solutions.





Bind easily integrates within the existing architecture; as a ceiling or suspended track, it allows designers to experiment with horizontal planes, ideal for spaces with high ceilings where it is necessary for light to be conducted to a lower height; and, as a hybrid combination, the collection lends itself to complex compositions of various atmospheres.



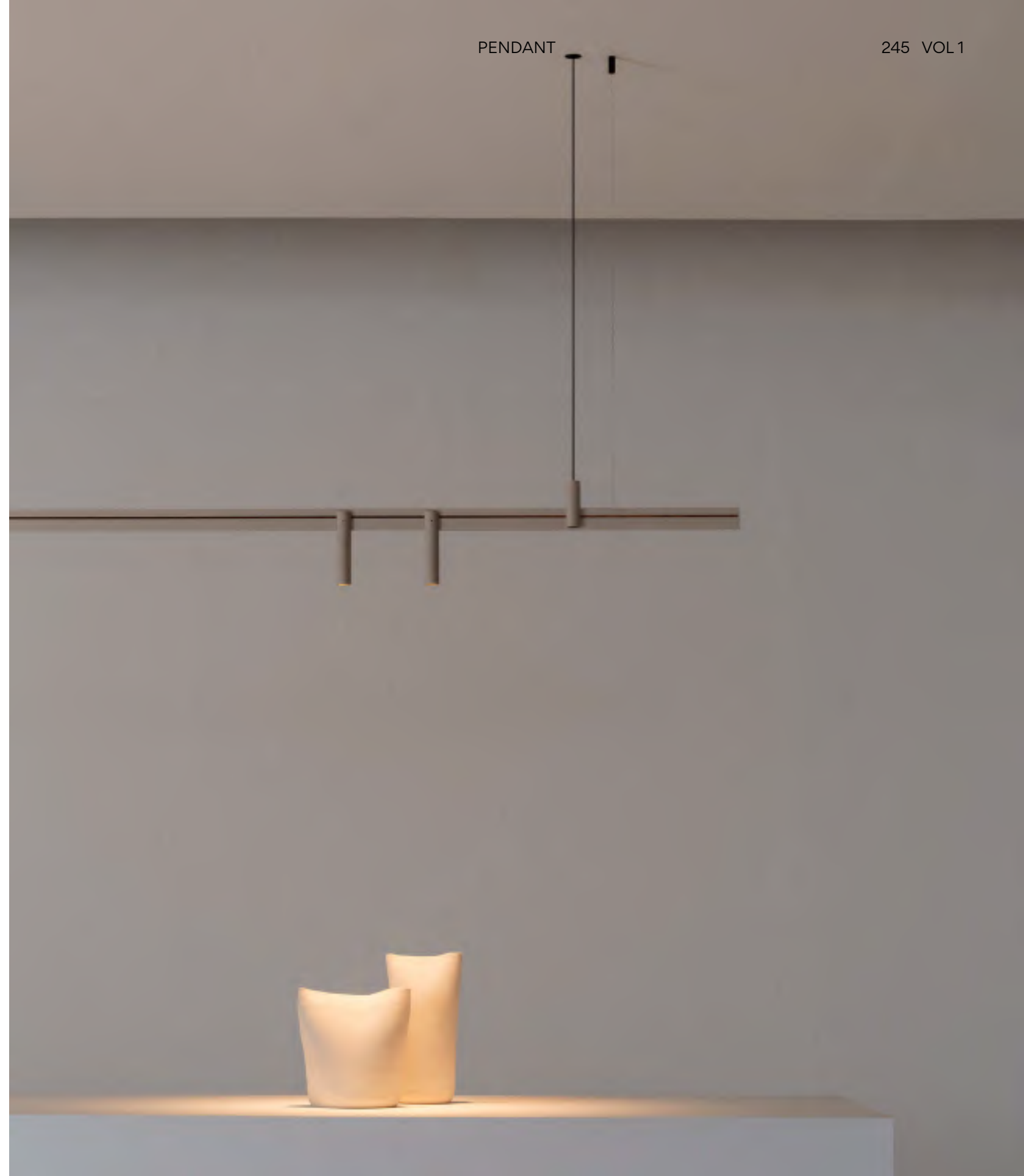
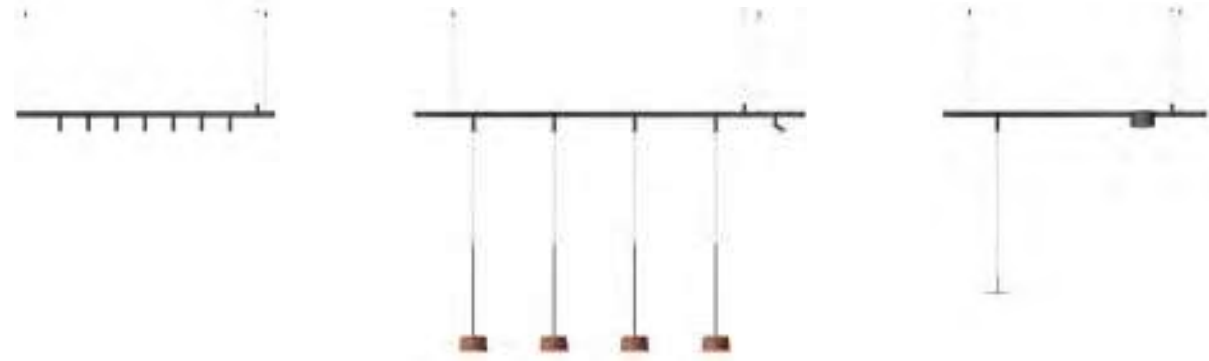



To highlight a particular activity zone or feature within the space, Bind track is also compatible with a series of spots and downlights that provide functional, accented lighting.





Multiple luminaires can be seamlessly connected to the track at any point, oriented to direct light in various directions. The different pieces are made in pincer format to be applied at any point of the track and move easily and immediately as desired.

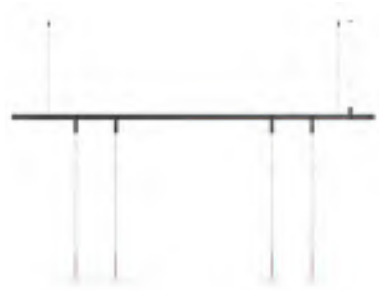



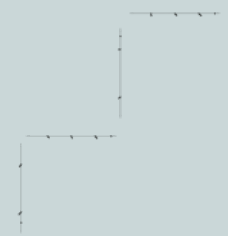
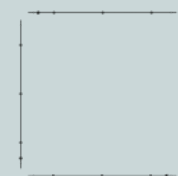
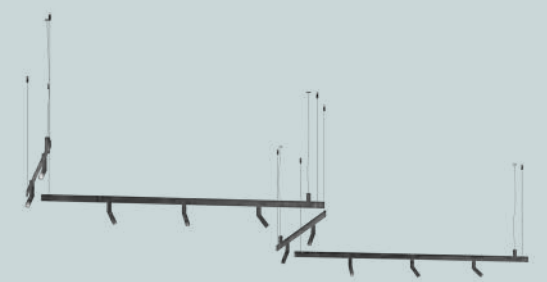
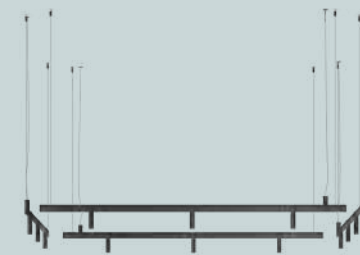

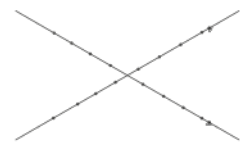
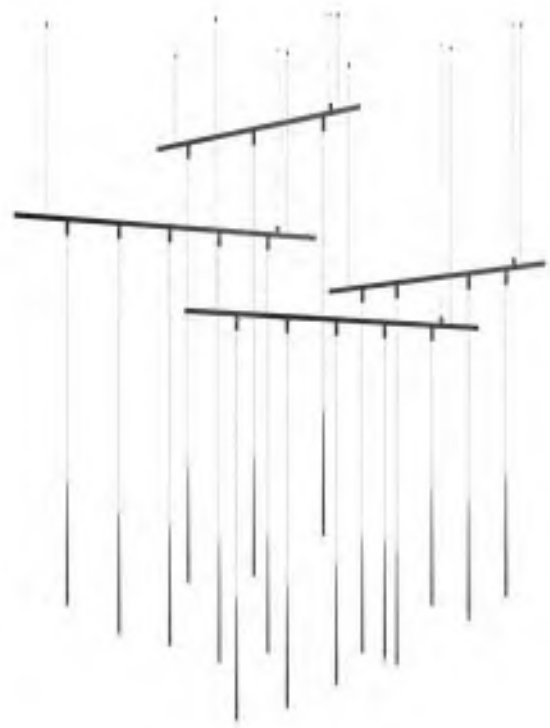
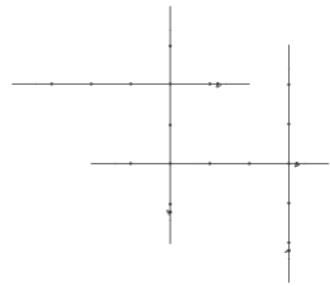

The Bind collection features ceiling surface and ceiling suspended track lighting, where a conductive bar or "track" represents the central element from which multiple luminaires can be fixed at any point. Bind track is compatible with a series of spots, downlights, lineal and general lighting fixtures that provide all types of functional lighting.

- 11 Black (NCS S 8500-N)
- 24 Beige M1 (NCS S 2005-Y50R)

Body: Aluminum
Diffuser: PC- Polycarbonate

LED Colour Temperature

Ø 3 cm
Static White
2700 K - 451 lm
3000 K - 471 lm
3500 K - 489 lm
4,3W

Ø 4 cm
Static White
2700 K - 530 lm
3000 K - 554 lm
3500 K - 574 lm
5,2W

Only ref. 6525, 6529, 6534 and 6538
Tunable White (1800 K - 4000 K)
Smart (P2P)
308 lm - 504 lm 5,5W

Ø 18,5 cm
Static White
2700 K - 1256 lm
3000 K - 1313 lm
3500 K - 1360 lm
12,4W

Tunable White (1800 K - 4000 K)
Smart (P2P)
571 lm - 895 lm 8,9W

CRI>90

Control

Analog: On/Off; Push; 1-10V (simultaneous line)
Digital: DALI-2 (simultaneous line)
Smart: Casambi (simultaneous line);
Casambi (P2P); ProtoPixel* (P2P)

*ProtoPixel products are compatible with all other DALI-2 products via a designated gateway (please consult us)

Updated detailed spec sheets on vibia.com

Wide Accent Downlight



Ø 18,5 cm
6540 Medium
6542 Wide

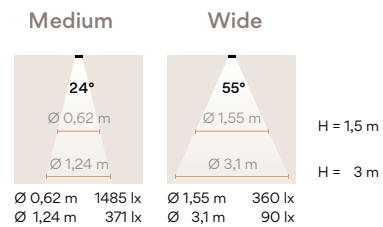

Accent Downlight



DOWNLIGHT Ø 3 cm
6500 Narrow
6504 Medium
Ø 3 x 15 cm



DOWNLIGHT Ø 4 cm
6520 Narrow
6524 Medium
6528 Wide
Ø 4 x 17,5 cm



6525 Medium
6529 Wide
Ø 4 x 20 cm

Accent Spotlight



SPOTLIGHT Ø 3 cm
6510 Narrow
6514 Medium
Ø 3 x 20 cm



SPOTLIGHT Ø 4 cm
6530 Narrow
6534 Medium
6538 Wide
Ø 4 x 22,5 cm

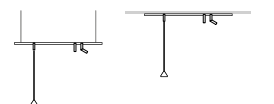
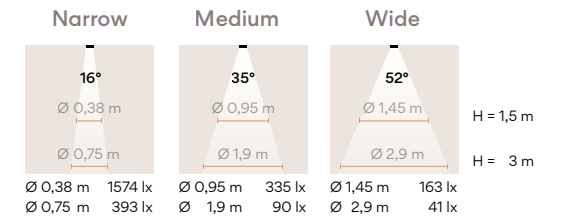
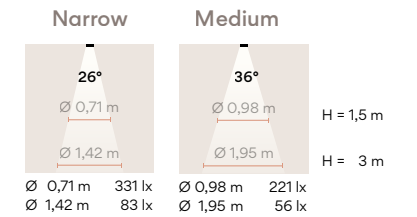

A conductive bar represents the central element from which multiple luminaires can be fixed at any point.

- 11 Black (NCS S 8500-N)
- 24 Beige M1 (NCS S 2005-Y50R)

Electrical connection options

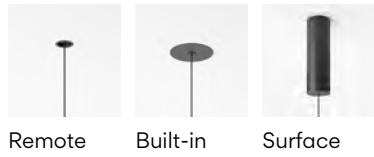

Pendant Tracks

- A419 120 cm
- A422 210 cm
- A425 300 cm

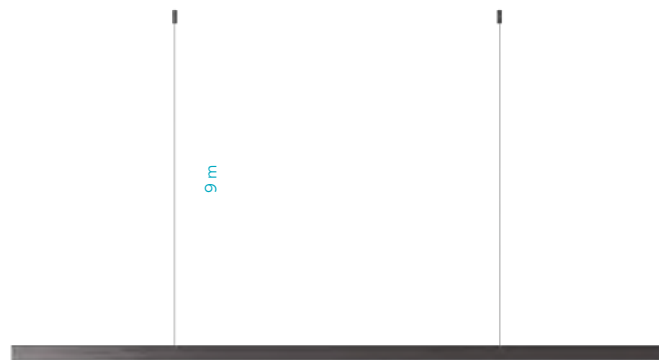

Dynamic light

Dynamic light allows professionals to play with subtle degrees of intensity and colour temperature to recreate a subtle ambience for every scene within a lighting project

Designing an atmosphere of wellbeing is based on two main axes: **space** and **time**. The axis of time implies the concept of dynamic light .

Atmosphere design is intentional, depending on the **design of different scenes according to the specific use of a space** as it evolves throughout the day. Light is dynamic because ambience also depends on **the time of day** and on the influence of the natural light at every moment.



Throughout the day our circadian rhythms respond primarily to light, which regulates our sense of physical and mental wellbeing

Comfortable environments

Vibia's spot accent, downlight and general lighting luminaires include the option of tunable white. Combining these zenithal tunable white lights with the rest of the diffused and indirect lighting effects of Vibia's portfolio, you can design the perfect scene for every moment and use.

Tunable lighting allows for comprehensive temperature regulation and intensity: colour temperature can be precisely tuned depending on the desired atmosphere for every scene.

Static White

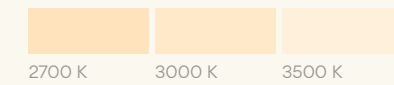

Tunable White

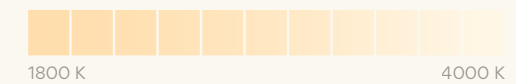

Contact Vibia Support Service at vibia.com for any kind of assistance or recommendation when designing an atmosphere of wellbeing, or if you require support with control system approach..

Bind track is compatible with the Skan, Slim, North, Tempo and Tube pendant collections, presenting a range of decorative silhouettes with multiple lighting effects. Single or multiple pendants can be suspended as desired, allowing for the formation of intricate chandeliers created from a compilation of tracks with multiple pendants.

Track adapter: Aluminum

LED Colour Temperature

2700 K; 3000 K; 3500 K
CRI>90

Control

Analog: On/Off; 1-10V (simultaneous line);
Digital: DALI-2 (simultaneous line);
Smart: Casambi (simultaneous line);
Casambi (P2P); ProtoPixel* (P2P)

*ProtoPixel products are compatible with all other DALI-2 products via a designated gateway (please consult us)

Updated detailed spec sheets on vibia.com

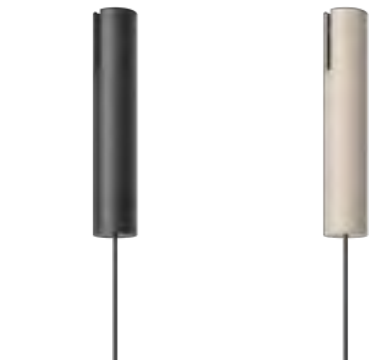

Track adapter

- Black (NCS S 8500-N)
- Beige M1 (NCS S 2005-Y50R)



6560 (Black)
6561 (Beige)

Skan Colours

- 10 White (NCS S 0300-N)
- 11 Black (NCS S 8500-N)
- 24 Beige M1 (NCS S 2500-Y50R)
- 37 Terra Red (NCS S 4040-Y70R)
- 42 Blue M1 (NCS S 5010-B10G)
- 47 Green L1 (NCS S 4005-G80Y)



6570 (Black)
6571 (Beige)

Slim Colours

- 10 White (NCS S 0300-N)
- 11 Black (NCS S 8500-N)
- 24 Beige M1 (NCS S 2500-Y50R)
- 37 Terra Red (NCS S 4040-Y70R)
- 47 Green L1 (NCS S 4005-G80Y)
- 68 Ocre (NCS S 3050-Y30R)



6575 (Black)
6576 (Beige)

North Colours

- 10 White (NCS S 0300-N)
- 11 Black (NCS S 8500-N)
- 24 Beige M1 (NCS S 2500-Y50R)
- 42 Blue M1 (NCS S 5010-B10G)



6590 (Black)
6591 (Beige)

Tube Colours

- 10 White (NCS S 0300-N)
- 15 Grey L2 (NCS S 2500-N)
- 16 Grey M1 (NCS S 4500-N)
- 21 Black Grey (NCS S 7000-N)
- 24 Beige (NCS S 2500-Y50R)
- 37 Terra Red (NCS S 4040-Y70R)



6580 (Black)
6581 (Beige)

Tempo Colours

- 18 Graphite (ADAPTA RF9913WX)
- 37 Terra Red (NCS S 4040-Y70R)
- 58 Cream (RAL 7044)
- 62 Green (NCS S 3010-G20Y)



6583 (Black)
6584 (Beige)

Tempo Colours

- 18 Graphite (ADAPTA RF9913WX)
- 37 Terra Red (NCS S 4040-Y70R)
- 58 Cream (RAL 7044)
- 62 Green (NCS S 3010-G20Y)



6586 (Black)
6587 (Beige)

Tempo Colours

- 18 Graphite (ADAPTA RF9913WX)
- 37 Terra Red (NCS S 4040-Y70R)
- 58 Cream (RAL 7044)
- 62 Green (NCS S 3010-G20Y)

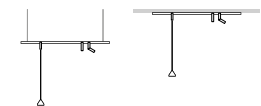

North



Design by Arik Levy.

North pendant collection consists of triangular Aluminum shades pendant from cables and adjustable carbon fibre rods. The rod and shade are disconnected from one another via nearly invisible cables in a dynamic system of adjustable parts, directing the LED-powered light where needed.



INDIVIDUAL MODEL



5660
Ø 16 cm



5662
Ø 40 cm



5664
Ø 60 cm



5670
Ø 16 cm



5672
Ø 40 cm



5674
Ø 60 cm

- 10 White (NCS S 0300-N)
- 11 Black (NCS S 8500-N)
- 24 Beige M1 (NCS S 2005-Y50R)
- 42 Blue M1 (NCS S 5010-B10G)

Finish customization
(Available options: Vibia colour palette)

Diffuser: PMMA
Shade: Aluminum
Rods: Carbon Fiber
Canopy: Steel

LED Colour Temperature
2700 K; CRI >90
3000 K; CRI >80
3500 K; CRI >90

Control
Individual model
Analog: Push; 1-10V
Digital: DALI-2
Smart: Casambi

Electrical connection options

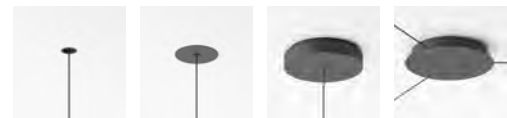

Remote Built-in Surface Free Wire

BIND related product

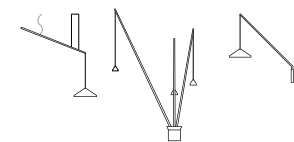

Pg 264/412 VOL 1 Pg 330 VOL 2

MULTIPLE MODELS

Set your composition at vibia.com

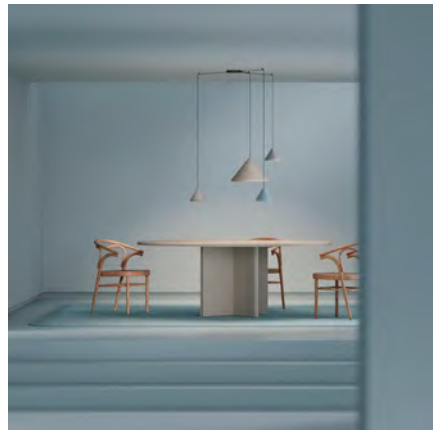
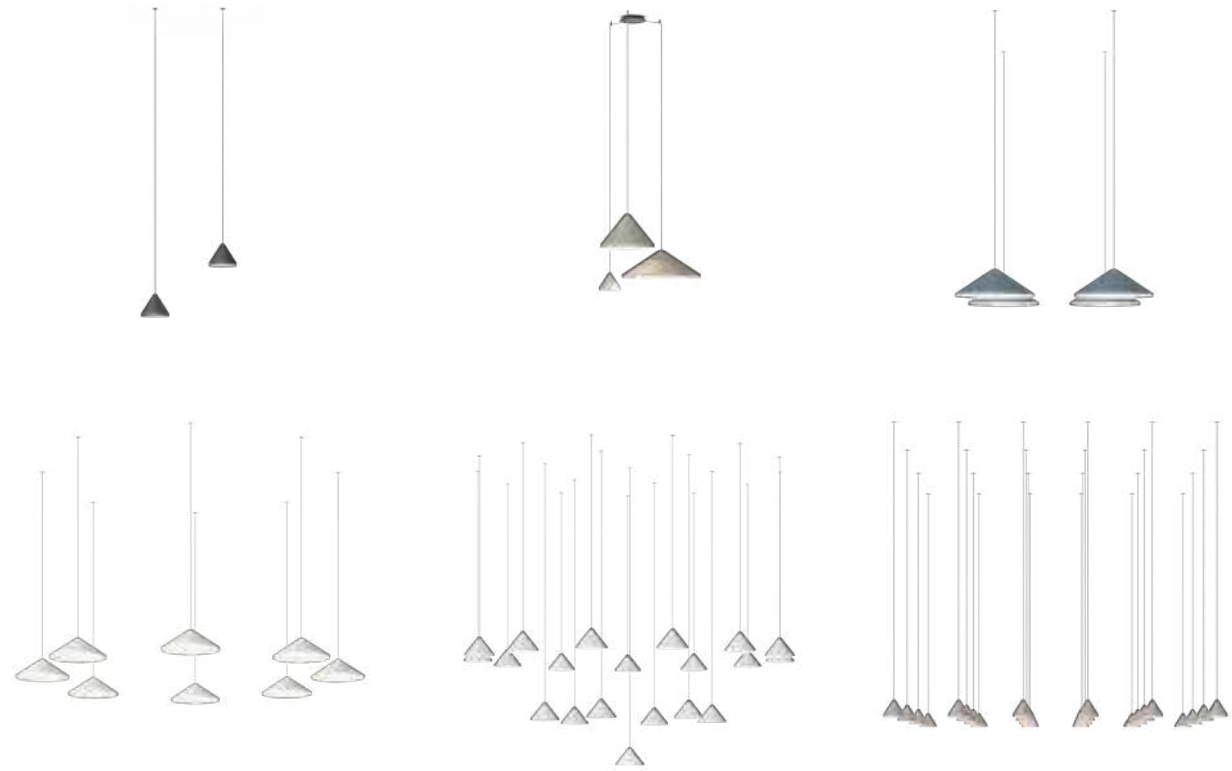

Plusminus

Plusminus

Visual Hierarchy
284

Raining Light
294

Flowing Pendants
300

Creative Canopy Connection
310

Defying Gravity
316

Suspended Animation
324

Reimagining Spaces
332

Framing Space
338

Plusminus^{+ -}

Design by Diez Office

Plusminus is a versatile lighting system that takes the concept of the light rail to a new level. The conductive textile ribbon at its core allows for free placement of the luminaires and the creation of unique light solutions on the spot.





The fluidity
of light

Equal parts easy and avant-garde, Plusminus harnesses the design of a belt in a groundbreaking lighting concept that merges materiality and light. Featuring a textural, fabric belt that conducts electricity, it enables light to flow through space. Plusminus provides professionals a powerful toolkit for creating personalised lighting effects and unique atmospheres with different luminaires via Vibia's digital platform and click-and-connect functionality.



Luminaire types and lighting effects



Sphere



Volumetric Diffuser

distributes light equally in all directions (360°). It attracts a relaxed gaze towards the point of light, and creates a calm, very comfortable atmosphere. The light sphere bathes all surfaces of the space, producing a peaceful, richer and extremely homogenous ambience.



Semisphere



Hidden Diffuser

emits a soft light that generates low contrasts between the illuminated areas and the shadows cast. The opaque part of the shade helps to direct the light through the diffuser, providing illumination that is both peaceful and concentrated at the same time.



Cone



Hidden Diffuser

emits a soft light that generates low contrasts between the illuminated areas and the shadows cast. The opaque part of the shade helps to direct the light through the diffuser, providing illumination that is both peaceful and concentrated at the same time.

Spotlight



Flat Diffuser

emits a soft light that generates low contrasts between the illuminated areas and the shadows cast. It is ideal for reading situations or when the light output is visible, as it does not produce glare.

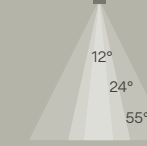

Accent

emphasizes objects or architectural elements with intensive cones of light. Luminance contrasts attract the eye and bring the illuminated objects into the foreground. The light output is directed towards the object or architectural element and not towards the person, in order to avoid glare.



Linear Diffuser



Linear Flat Diffuser

provides a high degree of uniformity on the horizontal plane and generates a first layer of illumination on which to add more specific lighting applications. It generates soft shadows and subdued brightness in which the space and its component elements do not display visual hierarchies.



Linear Low UGR



Linear High Efficiency Low Glare

offers medium brightness and clarity of forms. Direct illumination, extended beam and luminaire performance enable installations with high-energy efficiencies and low-glare levels below UGR<19.

Linear High Comfort Low Glare

provides high levels of illumination and comfort with UGR levels below 19. It is also ideal for work or meeting areas.



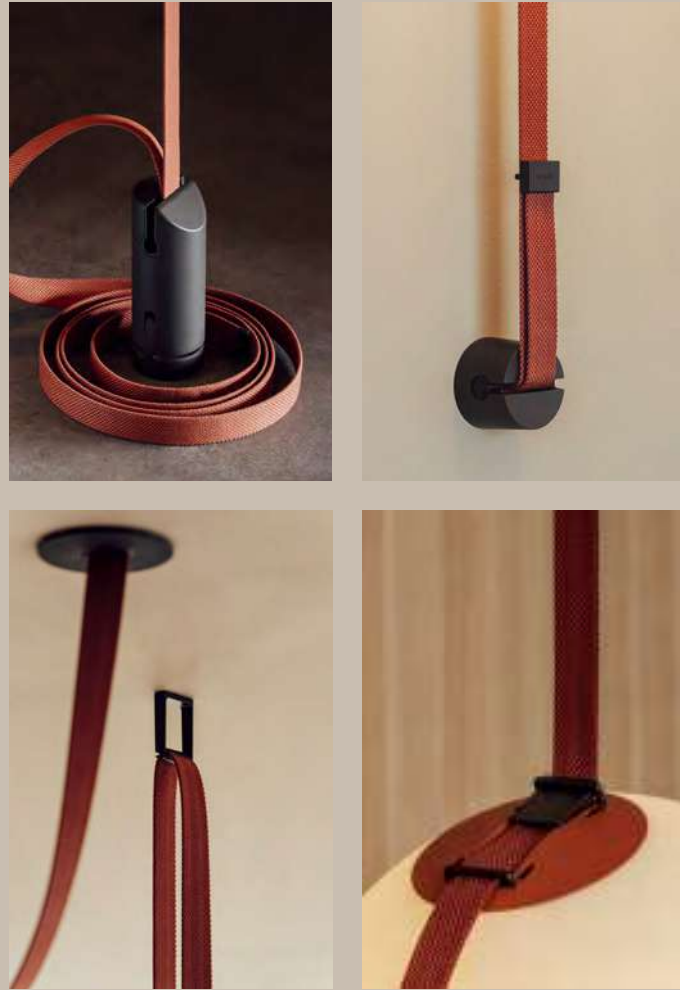

Easy connection
Fix / Click / Connect

Each belt, which can be cut as needed, accommodates multiple luminaires and operates with simple plug-in technology for unparalleled ease of installation and connection. The belt offers adjustments in tension from taut to relaxed as well as click-and-connect functionality, snapping into a buckle attached to each luminaire.



Shaping Atmospheres

Endlessly versatile, Plusminus offers the freedom to combine different levels of diffuse and focused illumination as never before to create a unique atmosphere in any interior.

Design a space by drawing with the belt, conducting light to the right place while evoking an emotional response and sense of wellbeing.

Visual Hierarchy

Raining Light

Reimagining Spaces

Framing Space

Defying Gravity

Flowing Pendants

Creative Canopy Connection

Suspended Animation

Visual Hierarchy

Plusminus's revolutionary belt design provides a powerful toolkit for reimagining spaces. Combining multiple lighting effects and placing light precisely where needed, it creates visual hierarchies in any space.

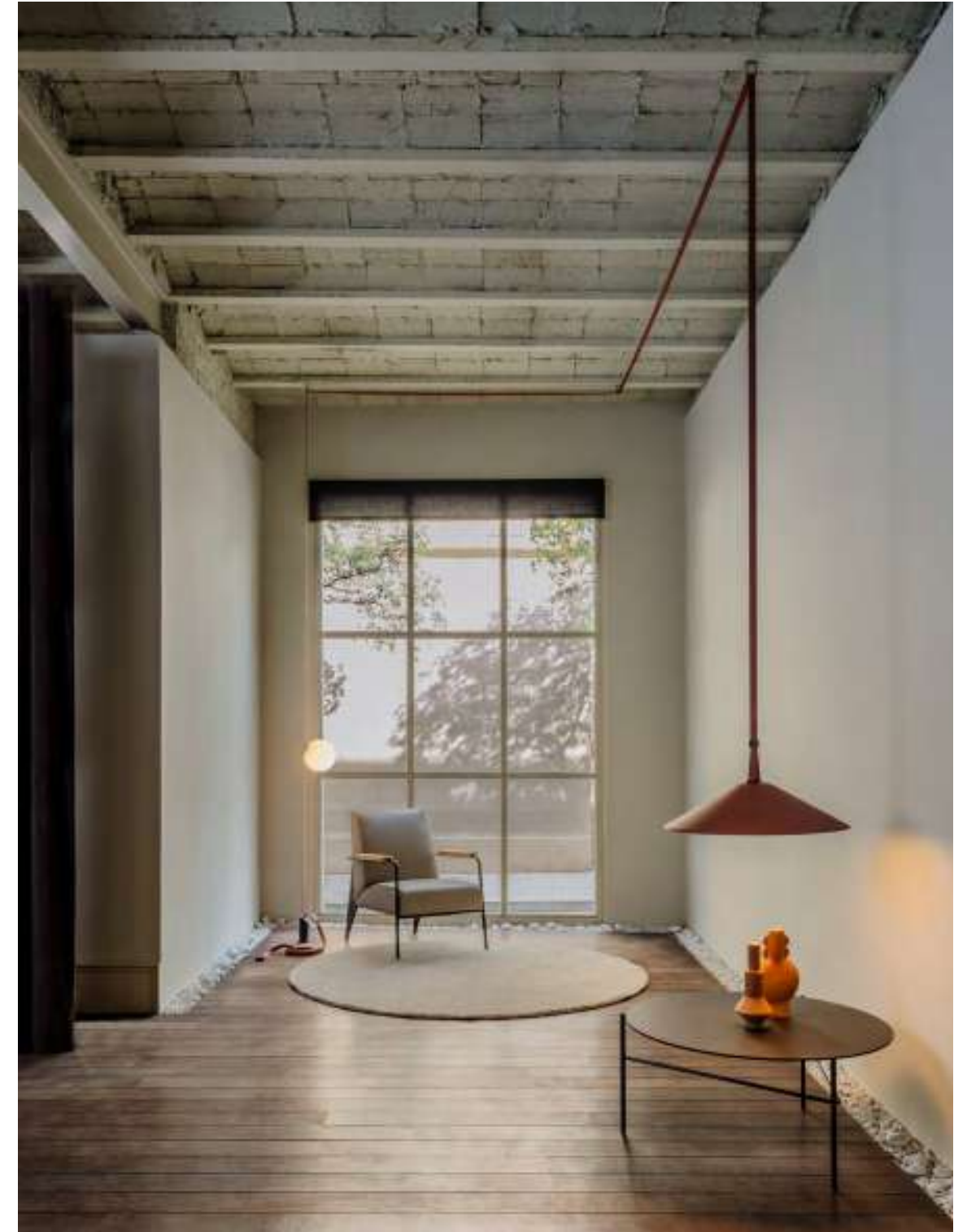



The fabric belt offers endless flexibility of use, conducting light across a range of ceiling shapes and angles.

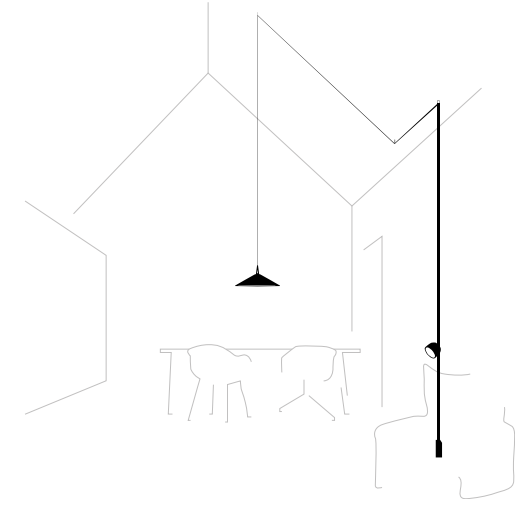





Place multiple lights in different positions throughout a space with just a single electrical connection.

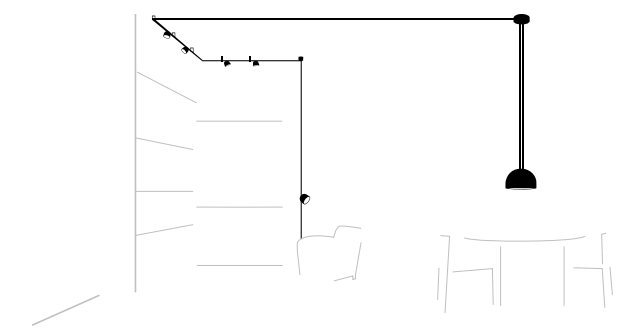

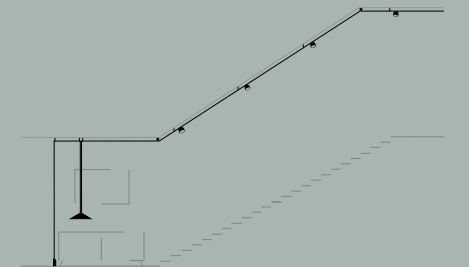
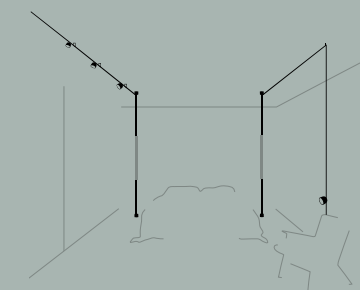
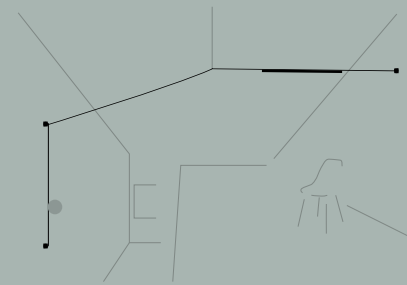
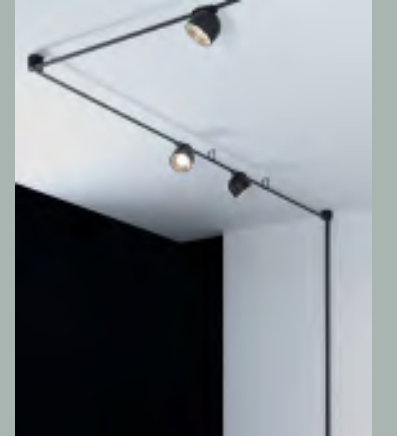

An invitation to position light without limits, Plusminus accommodates any kind of architecture—no matter how unique.

Raining Light

From a single spotlight positioned close at hand to a cascading installation of luminaires overhead, Plusminus's ceiling-to-floor possibilities create a stunning display of light in varying intensity and effect.



Plusminus's powerful design capabilities include constructing columns of light up to 60 meters high.

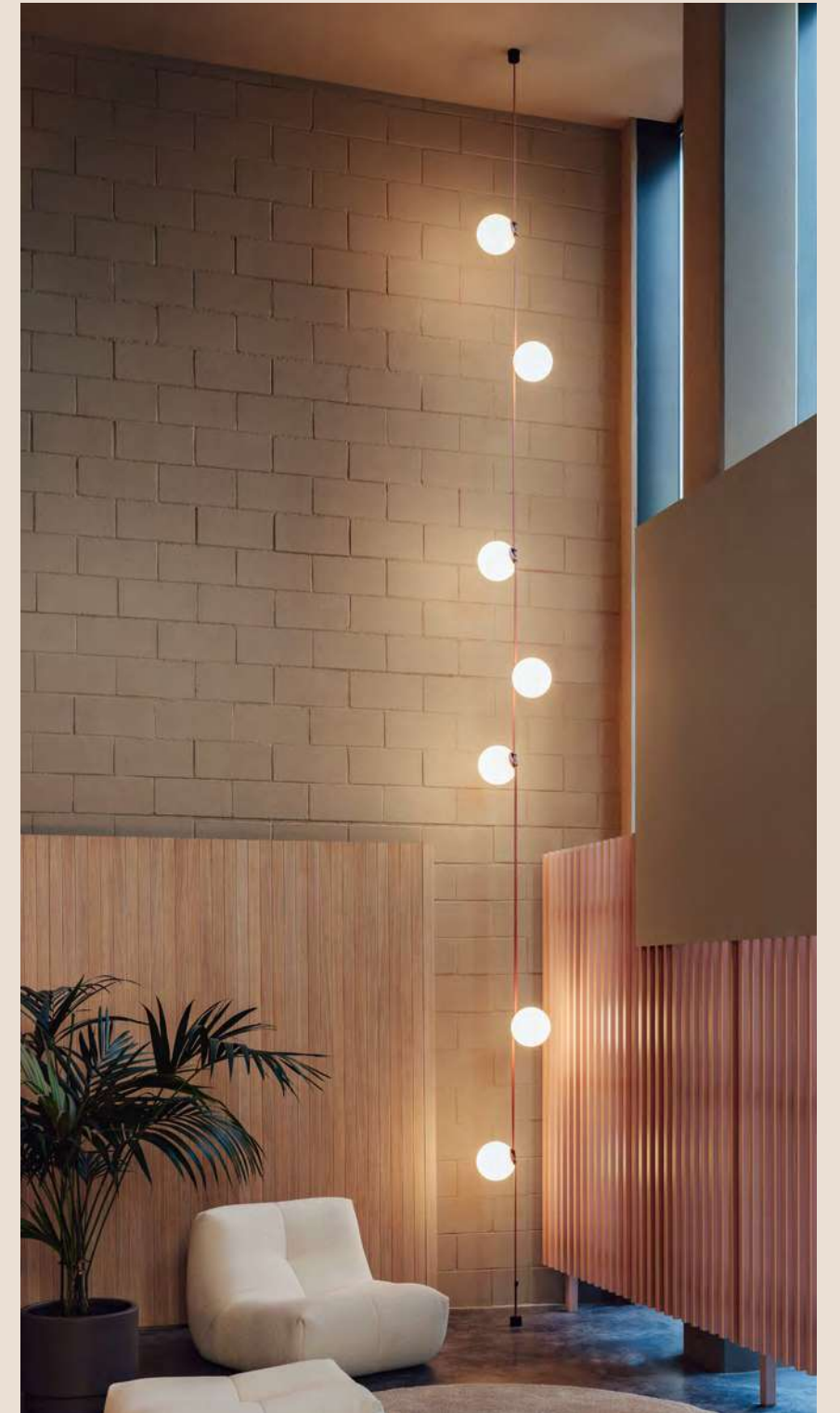



Climbing the Walls

An innovative take on the wall lamp, Plusminus's fabric belt forms a linear architecture that hosts an array of lighting options—from a long row of accent lamps illuminating a hallway to sleek luminaires straddling opposite walls.



Flowing Pendants

Defined by their flowing, continuous forms, Plusminus pendants provide endless possibilities for illuminating a space. Suspended overhead in silhouettes, soft and draped or taut and precise, their graphic presence creates distinctive ambiances.





“The Plusminus collection is a toolbox which, thanks to the wide range it contains, enables you to find solutions to an incredible number of lighting problems. I think architects and lighting designers today need investment certainty, and Plusminus offers that.”

Stefan Diez

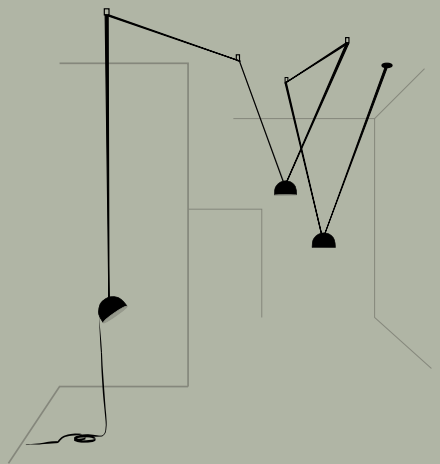

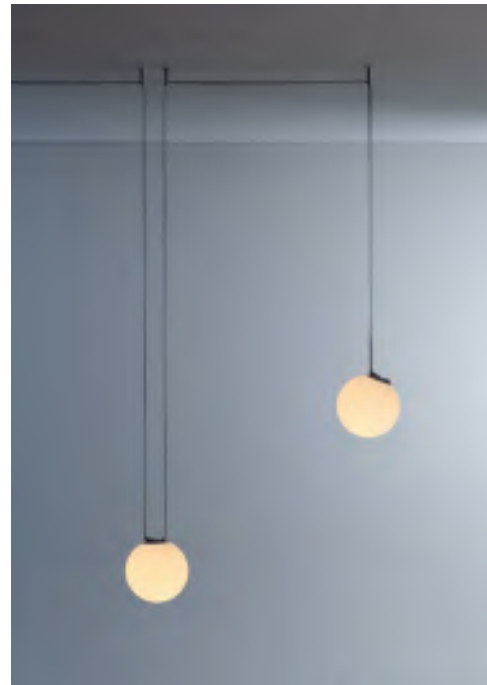
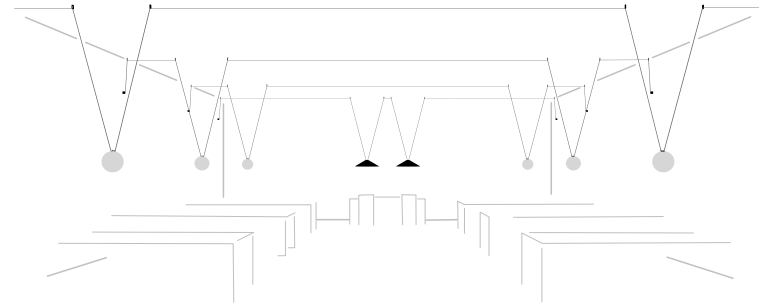

Composing Light

Both object of beauty and high-performance lighting toolkit, Plusminus offers personalised atmospheres while doubling as striking visual sculpture.



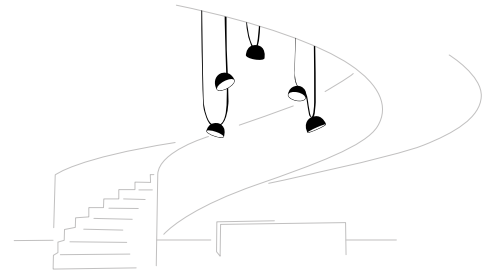

Creative Canopy Connection

Plusminus reimagines the use of the canopy. The belt flows in and out of the canopy, establishing conductivity and electrical connection where needed, with creative configurations becoming an essential element of the design.



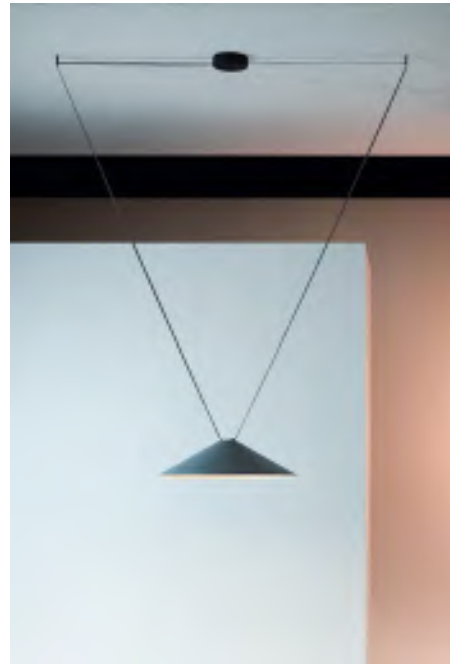
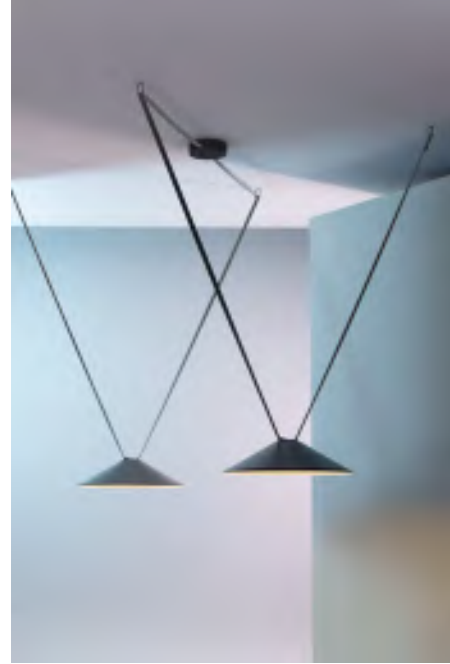



A surface canopy presents yet another opportunity to play with Plusminus, securing the belt in one spot while allowing it to flow freely across a space in countless configurations.

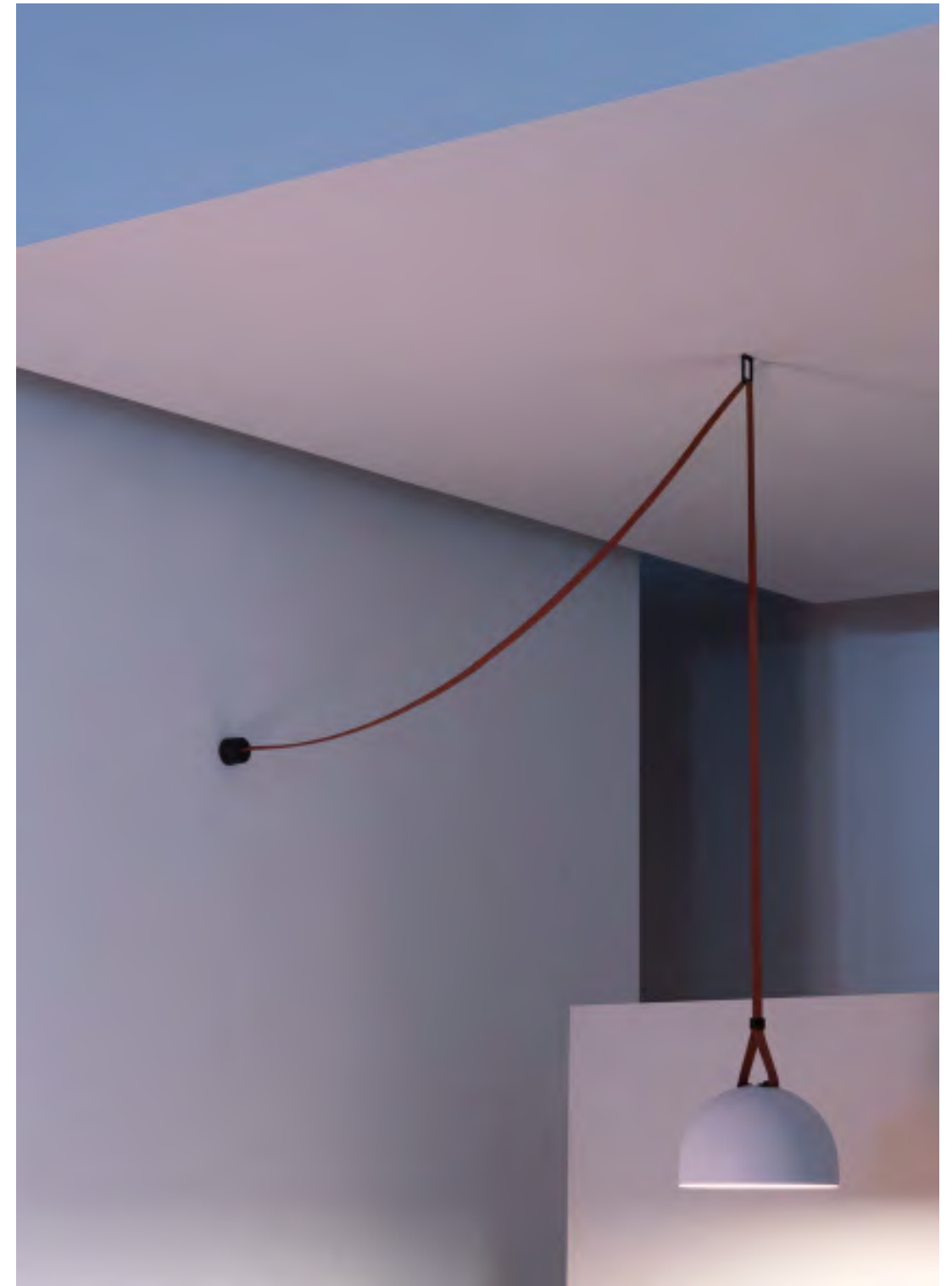

Defying Gravity

Plusminus's nearly invisible tensor wire introduces an element of intrigue to lighting. The wire extends from the belt to the wall or the ceiling, quietly completing the luminaire's design while lending it the magical look of floating in midair in defiance of gravity.





Balancing Act

Wall-to-wall installations hang in a delicate balance with Plusminus's invisible ceiling tensor. Lifting or lowering the belt, the cable creates varying degrees of tension that enables infinite configurations.





Suspended Animation

Ceiling design no longer limits lighting options thanks to Plusminus. A bar suspended from the ceiling serves as both a sleek architectural feature and an opportunity for creative exploration.



Play with height and length to suit any setting and affix personalised belt designs for a one-of-a-kind look.



Bar length 2 m
Tensor cables max. 5 m

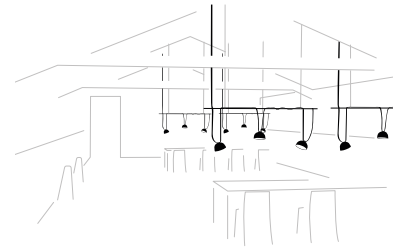





Reimagining Spaces

Merging light and materiality, Plusminus introduces masterful new ways to delineate space. Tracing a slender outline, the fabric belt creates a contained area within an open layout, serving as an illuminated perimeter with minimal presence.





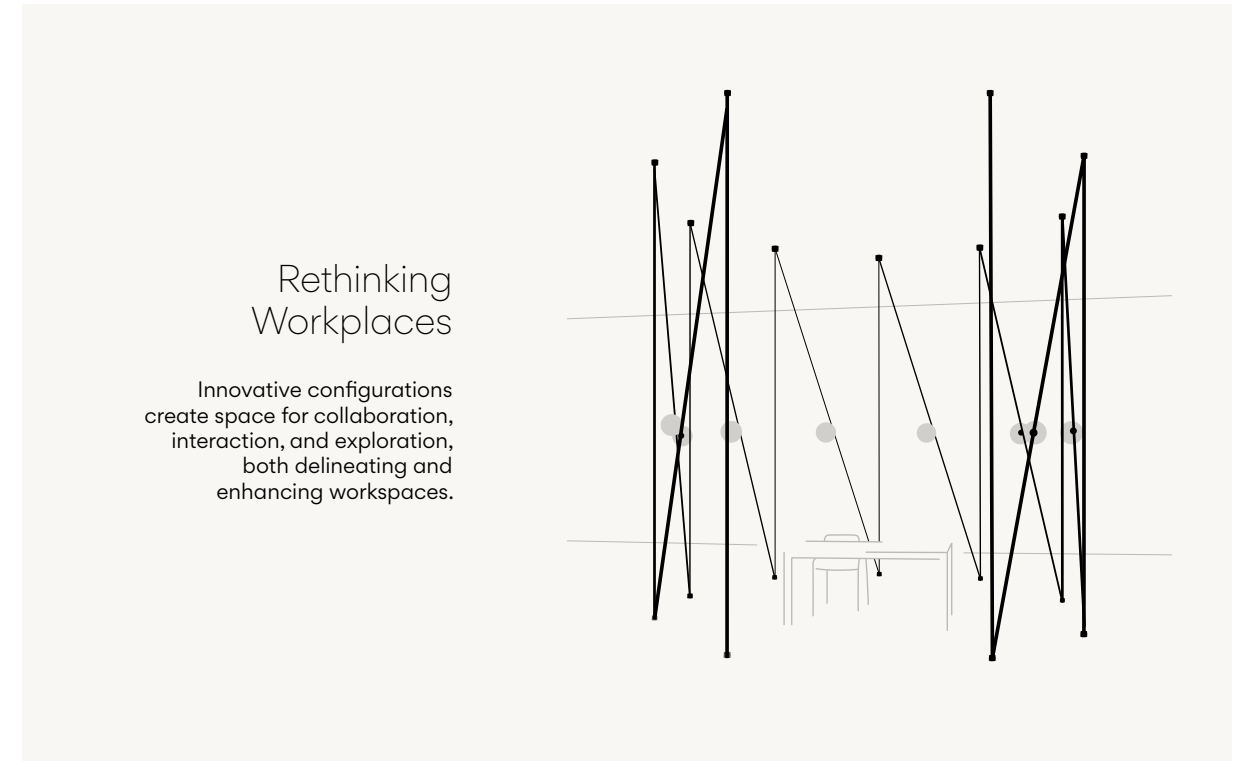
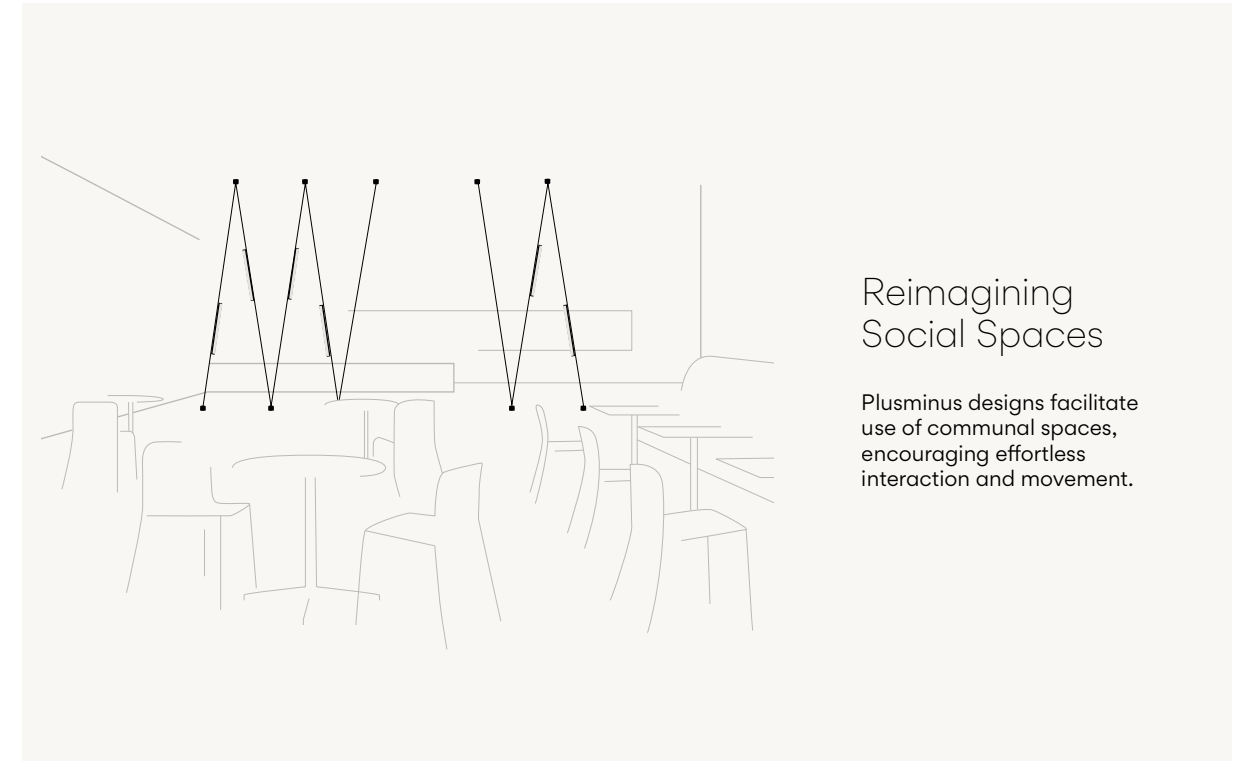

Framing Space

Plusminus's lean lines define an interior with precise transverse trajectories. Stretching from wall to wall, the belt evokes the effect of a false ceiling, reducing a room's volume and bringing light closer. With kinetic crisscrossed and zigzagged configurations or soothing straight lines, the luminaires appear integrated into the architecture.



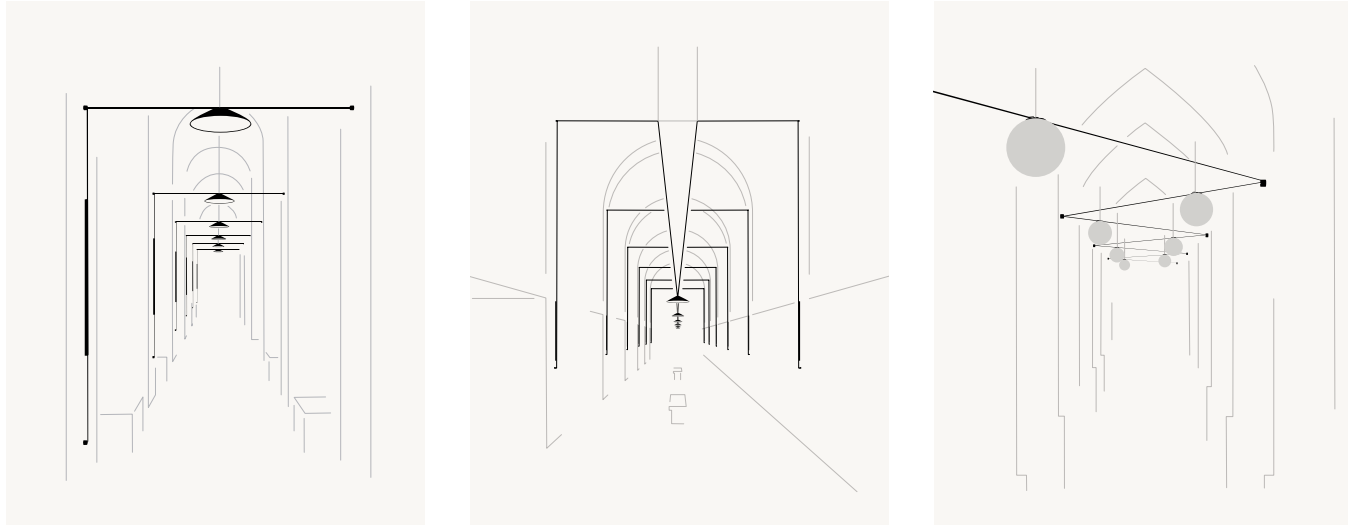

Plusminus's nearly invisible tensor wire introduces an element of intrigue to lighting. Lifting or lowering the belt, the cable creates varying degrees of tension that enables infinite configurations.



Plusminus' inherent adaptability provides the perfect solution for spaces that feature special architecture, scale, materials, or artwork.



Belt

- Black
- Terra Red
- Blue
- Green
- Beige

Maximum 60 meters length
per electrical connection point

Fire Hazard Testing.
GW-960. fulfills the requirements of:
standards EN 60695-2-10:2013;
EN 60695-2-11:2015;
EN 60695-2-12:2011 / A1:2014

Belt: Polyester

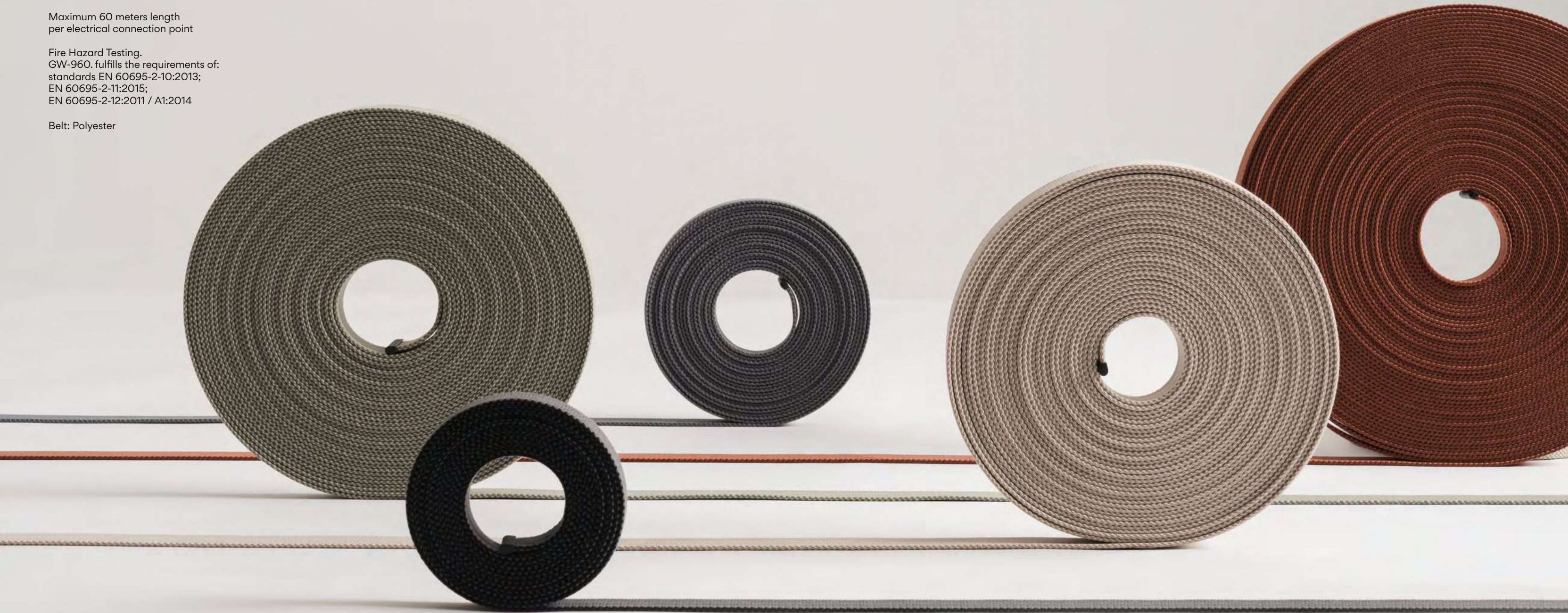

Luminaires types

- 11 Black (NCS S 8500-N)
- 24 Beige M1 (NCS S 2005-Y50R)
- 37 Terra Red (NCS S 4040-Y70R)
- 42 Blue M1 (NCS S 5010-B10G)
- 53 Green M1 (NCS S 6005-G80Y)

LED Colour Temperature
 LED 2700 K; 3000 K; 3500 K
Accent
 2700 K - 941 lm
 3000 K - 987 lm
 3500 K - 1022 lm
 7,9W
 CRI>90

Control
 Analog: On/ Off; 1-10V; Push
 Digital: DALI
 Smart: Casambi; Casambi integrated on each individual luminaire (P2P); ProtoPixel Simultaneous*; ProtoPixel integrated on each individual luminaire (P2P)*
 *ProtoPixel products are compatible with all other DALI-2 products via a designated gateway (please consult us)

Sphere



6230
Ø 20 cm

6235
Ø 30 cm

Semisphere



6220
Ø 20 cm

6225
Ø 30 cm

Cone



6240
Ø 60 cm

6245
Ø 80 cm

Spotlight



Accent
6200 Narrow
Ø 10 cm

Accent
6205 Medium
6210 Wide
Ø 10 cm

Flat diffuser
6215
Ø 10 cm

Spotlight - Accent

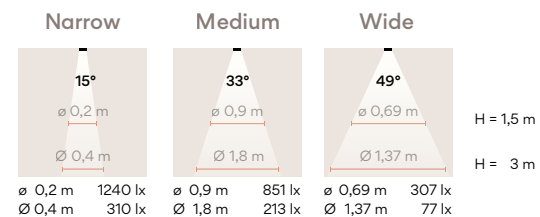

Updated detailed spec sheets on vibia.com

Linear Diffuser



6250
102 x 4 x 3 cm

6255
202 x 4 x 3 cm

Linear High Comfort Low Glare



6260
26,8 x 7 x 3 cm

6265
52,5 x 7 x 3 cm

6270
103,7 x 7 x 3 cm

Linear High Efficiency Low Glare



6275
26,8 x 7 x 3 cm

6280
52,5 x 7 x 3 cm

6285
103,7 x 7 x 3 cm

Electrical connection options

Choose your preferred installation option according to your needs.



Dimming control options

Choose your preferred installation option according to your needs.

| Dimming Control | Electrical Connection | | | |
|--|-----------------------|------------------------|----------------------|-----------------|
| | Surface 25 - 240 W | Built-in 25 - 240 W | Remote 25 - 240 W | Plug Max 60W |
| On/ Off | ✓ | ✓ | ✓ | ✓ |
| Push Switch | — | — | — | ✓ |
| Push Simultaneous | ✓ | ✓ | ✓ | — |
| 1-10V Simultaneous | ✓ | ✓ | ✓ | — |
| DALI Simultaneous | ✓ | ✓ | ✓ | — |
| Casambi Simultaneous | ✓ | ✓ | ✓ | ✓ |
| Casambi integrated on each individual luminaire (P2P) | ✓ | ✓ | ✓ | ✓ |
| ProtoPixel Simultaneous | ✓ | ✓ | ✓ | ✓ |
| ProtoPixel integrated on each individual luminaire (P2P) | ✓ | ✓ | ✓ | ✓ |

Belt Options Surface Canopy

Choose your preferred installation option according to your needs.



Belt terminations

Belt terminations can be adjusted during the installation process according to your preference.

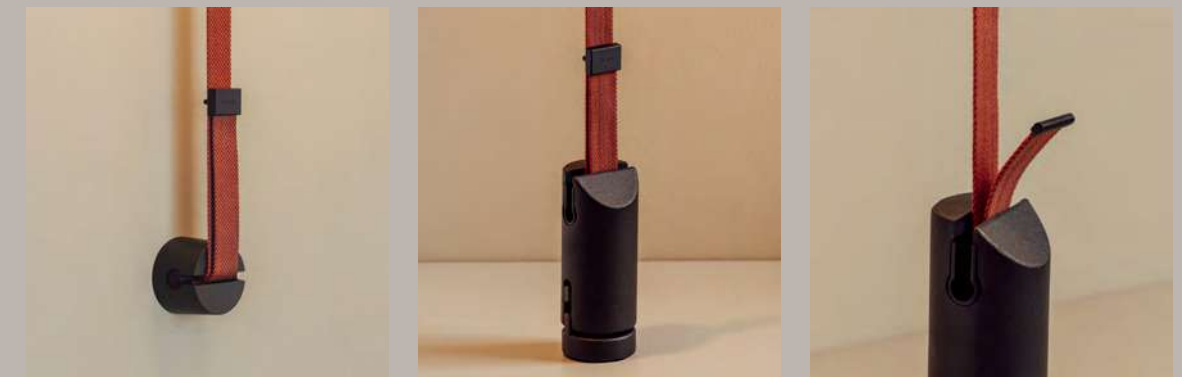
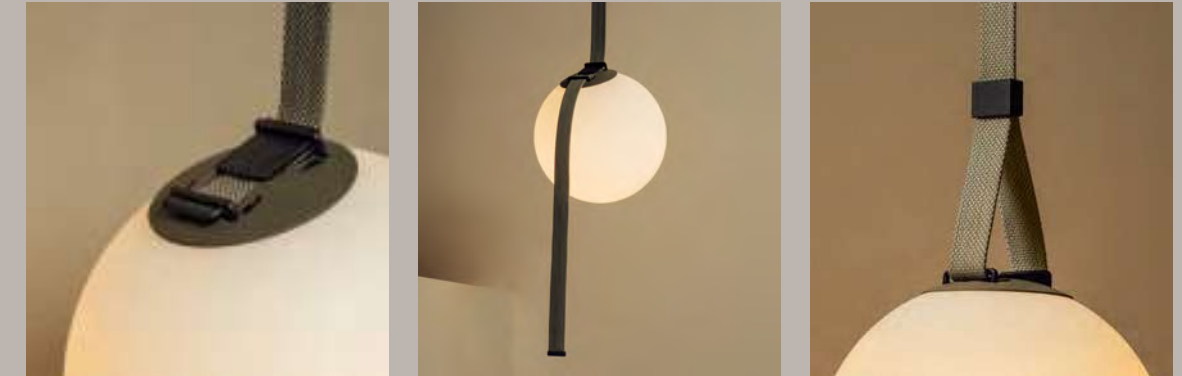

Easy to design and install

Compose a personalised Plusminus
at vibia.com

From scratch



- + Create and compose projects in detail.
- + Draw and personalise in 3D to see it in space.
- + Or personalise it step by step without drawing.

From of a layout

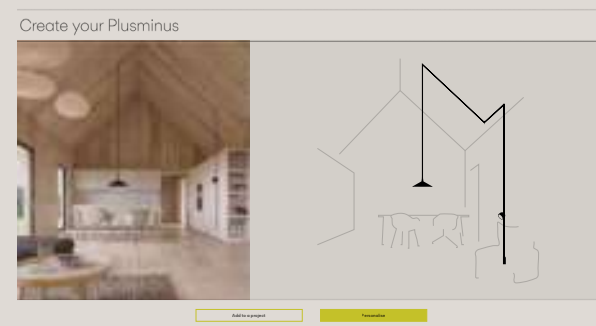

- + Personalise and adapt it to the needs of your project.
- + Add it to your project and edit it at any time.
- + More than 100 creations for you.

Accessories Toolbox

Thought out to the smallest detail.
Receive your personalised accessories toolbox
for a quick and easy installation.



352 VOL 1

PLUSMINUS

353 VOL 1



Floor & Table

Floor & Table

Africa
356

Balance
400

Dama
364

Flat
405

Ghost
438

I.Cono
424

Jazz
444

Knit
378

Lily
372

Mayfair
394

Mayfair
Mini
388

Musa
454

North
412

Offset
460

Out
468

Pin
418

Plusminus
Solo
472

Skat
434

Sticks
Solo
384

Suite
430

Warm
448

Africa



Design by Francisco Gomez Paz.

An object of desire, Africa is a unique gift that combines richness of form and materiality with high performance lighting capabilities. A holistic exploration of beauty and functionality.





“Africa was born as a response to new nomadic, free and casual ways of inhabiting, in which residential and professional spaces are increasingly hybridised”.

Francisco Gomez Paz



Portable

Its chargeable LED light source provides three levels of intensity which are controlled by a simple push button at the head.

Bolt-down

The bolted version is fixed in position, designed to integrate within the surrounding architecture.



1st Pulse
Intensity 33%

2nd Pulse
Intensity 66%

3rd Pulse
Intensity 100%

Battery capacity
10.000mAh

Battery voltage
3,7V

Battery autonomy:
6,5h at 100% Intensity
10h at 66% Intensity
20h at 33% Intensity





5580
Ø 5 x 45 cm

5585
Ø 5 x 40 cm

Portable

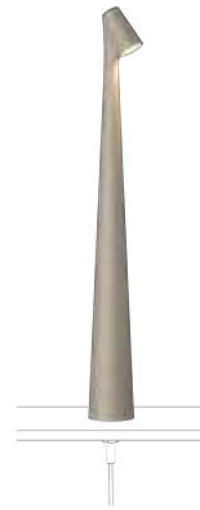

5590 Bolt-down
Ø 5 x 45 cm



5595 Bolt-down
Ø 5 x 40 cm

Bolt-down

- 24 Beige M1 (NCS S 2005-Y50R)
- 25 Beige D1 (NCS S 4005-Y50R)
- 29 Brown D1 (NCS S 8005-Y50R)
- 38 Terra Dark (NCS S 5040-Y70R)
- 83 Walnut (Tray)

Body: Aluminum
Diffuser: PC- Polycarbonate
Tray: Wood (Rustic Walnut)

LED Colour Temperature
2700 K
CRI>90

Control
Analog: Push



A439

Ø 27 cm



A440

Ø 27 cm

Tray that allows three or two luminaires to be charged by contact

To recharge the luminaire, the shaft slides seamlessly into a magnetised charger, a flawless continuation of its sculptural expression.



Dama



Design by Ludovica+Roberto Palomba.

A homage to the Abat-Jour lamp, the Dama collection connects the charm of tradition with the finesse of contemporary lighting design. Combining technical precision with aesthetic simplicity, Dama is ideal for shaping an intimate atmosphere with an elevated look.



Distinguished by its exposed frame, a cylindrical shade rests neatly on top of a slender aluminium stem which branches out into three legs available in two stylish finishes. The delicacy of the frame provides a feeling of weightlessness, enhanced by the softness of the paper diffuser.





“Paper, with its ‘imperfect perfection’, gave us precisely the sense of warmth that we were looking for, and at the same time a sense of lightness”.

Ludovica+Roberto Palomba



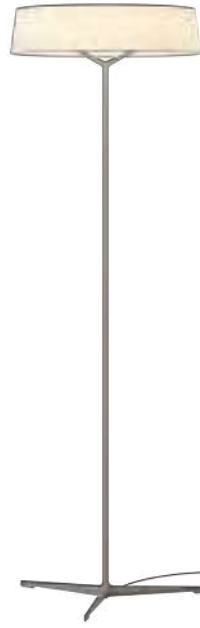

3230
Ø 49,5 x 140 cm



3225
63,5 x 61 cm

- 11 Black (NCS S 8500-N)
- 25 Beige D1 (NCS S 4005-Y50R)

Tube: Steel
Base: Zinc Alloy
Shade: Paper

LED Colour Temperature
2700 K
CRI>90

Control
Analog: Push
Smart: Casambi; ProtoPixel*
*ProtoPixel products are compatible with all other DALI-2 products via a designated gateway (please consult us)

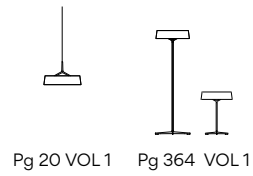

With a desire for integrity, Dama incorporates a circular LED with an internal diffuser, projecting a warm 360 degree glow from an invisible source.



Floor switch



Table switch



Lily



Design by Ludovica+Roberto Palomba.

The Lily collection reveals contemporary lines with an ineffable lightness. Its graceful glass diffuser radiates with warmth and wellbeing, ideal for an elegant interior with a relaxed ambience.

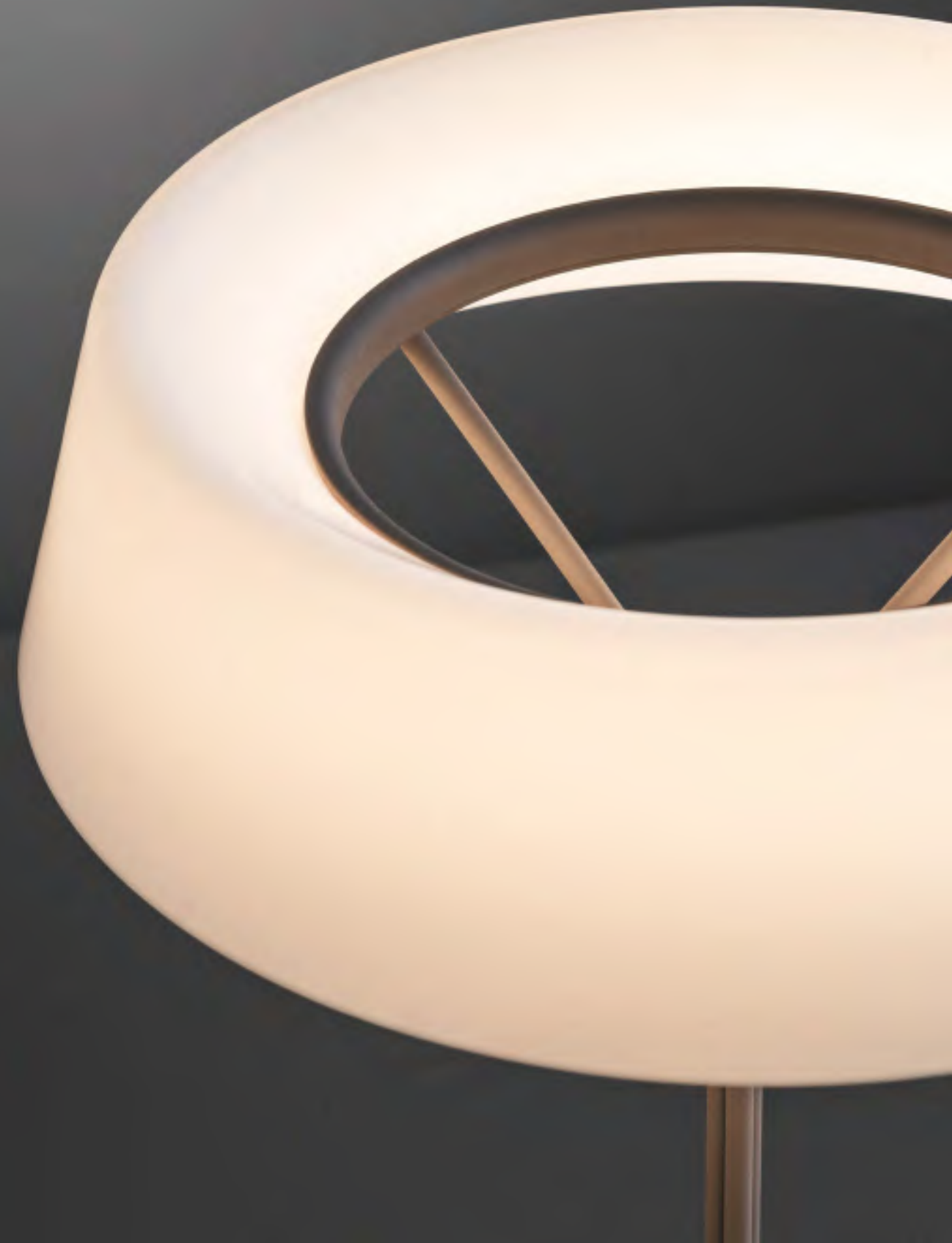





Pairing timeless design with an ambient 360 degree glow, Lily is as intimate in performance as it is elegant in form.

A contemporary reimagining of the classic lampshade, it is characterised by a smooth, translucent glass diffuser which gently curves over at the top to conceal an invisible LED light source. A elegant aluminium stem denotes appeal as well as stability. The base consists of three or four rods which meet in the centre before branching out at the top to support the diffuser. The slender nature of the stem accentuates the sensuous curve of the diffuser.

- 11 Black (NCS S 8500-N)
- 25 Beige D1 (NCS S 4005-Y50R)

Body: Steel
Shade: Triple opal blown glass

LED Colour Temperature

2700 K
CRI>90

Control

Analog: Push
Smart: Casambi; ProtoPixel*

*ProtoPixel products are compatible with all other DALI-2 products via a designated gateway (please consult us)



5720
Ø 49 x 63,5 cm

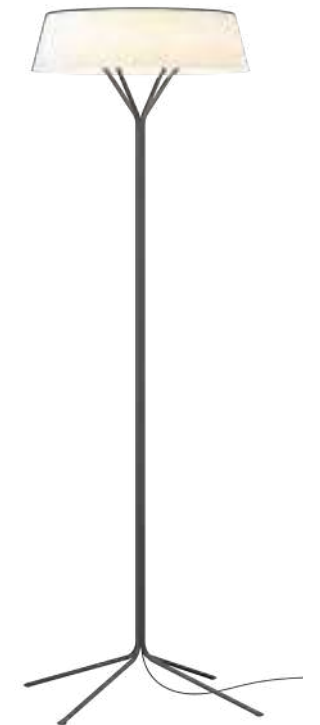

5725
Ø 49 x 155 cm



Floor switch



Table switch



Knit



Design by Meike Harde.

Light, materiality and tangibility collide with the Knit collection. Its texture is magnetic, calling out for us to touch its surface, to feel its warmth and to keep it close. Light seeps outwards through the fabric transmitting a soft 360° glow.





A single knitted lycra sleeve stretched over an ovoid polymer diffuser, its texture is magnetic, calling out for us to touch its surface, to feel its warmth and to keep it close.

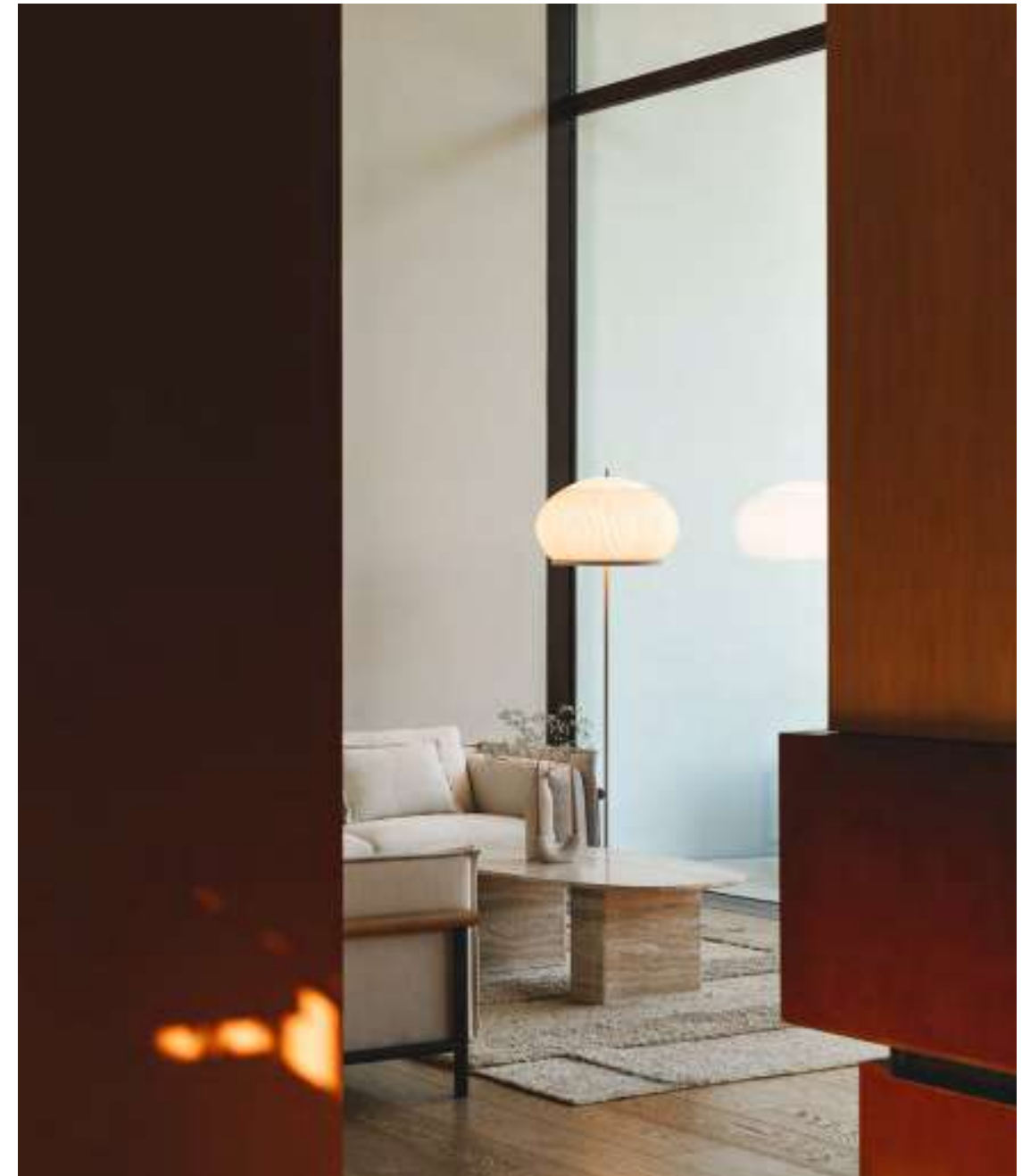



7480
Ø 45 x 178 cm



7485
Ø 45 x 170 cm



7487
Ø 65 x 195 cm



7490
Ø 45 x 55 cm



7492
Ø 65 x 51 cm



7494
Ø 65 x 62 cm

● 24 Beige M1 (NCS S 2005-Y50R)

Fabric shade: PES FR
Interior diffuser: PE- Polyethylene
Botom diffuser: PC- Polycarbonate
Diffuser ring and support: ABS
Stem: Iron
Floor base: Zinc Alloy

LED Colour Temperature

2700 K
CRI>90

Control

Analog: Push
Smart: Casambi;
ProtoPixel*

*ProtoPixel products are compatible with all other DALI-2 products via a designated gateway (please consult us)



Floor switch Ref.
7480, 7485, 7487



Sticks Solo



Design by Arik Levy.

Sticks Solo floor can be free-standing or arranged floor to wall, connecting two planes of the same space. The stand alone model features one or two Sticks that produce a pleasant ambient lighting effect or indirect light depending on rod rotation.



● 11 Black (NCS S 8500-N)

Stick: Aluminum
Diffuser: PC- Polycarbonate

LED Colour Temperature
2700 K; 3000 K; 3500 K
CRI>90

Control
Analog: Push



Floor base & plug

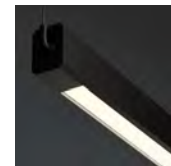

Linear flat diffuser



High energy efficiency and low glare levels
UGR<19 for horizontal application
Ref. 7376, 7379

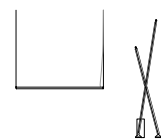

Pg 74/384 VOL 1

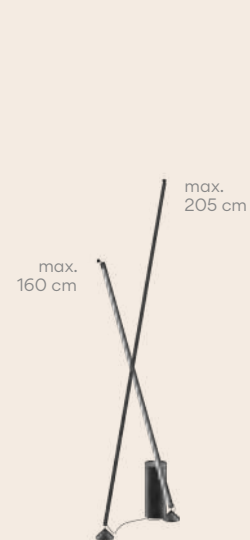

7338



7339



7348

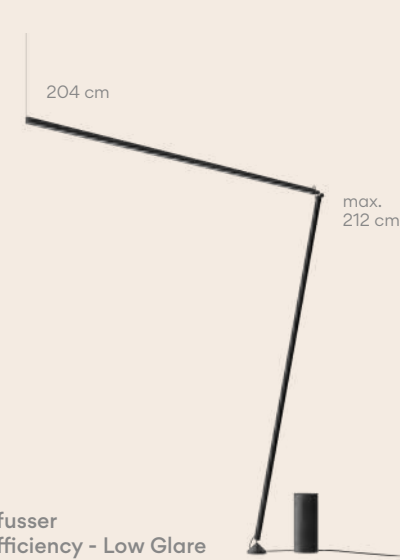

7375 Flat Difusser
7376 High Efficiency - Low Glare

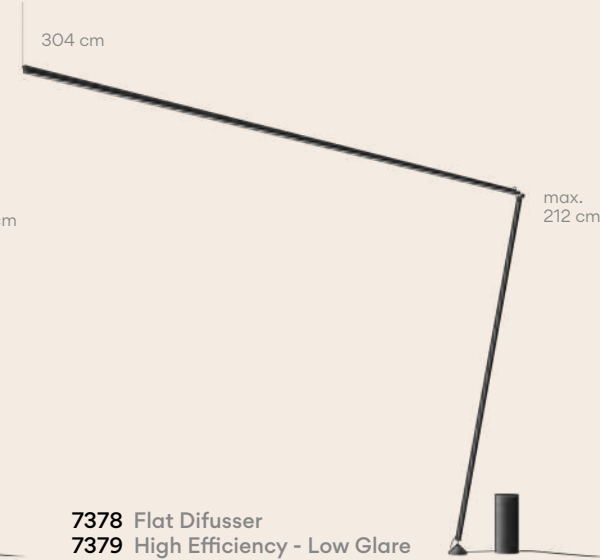

7378 Flat Difusser
7379 High Efficiency - Low Glare

Mayfair Mini



Design by Diego Fortunato.

The perfect lighting companion, the Mayfair Mini is a small-scale design that casts a contained pool of diffuse, downlight for an intimate atmosphere. A light to grab and go that can be moved where needed -indoors or out- via its slender stem.



The Mayfair Mini is offered in three formats. The portable version is perfect for indoor and outdoor use. Powered by a rechargeable battery, it can be transported to any desired position. It also comes in two bolted versions, available either with a base. The bolted formats are fixed in position, designed to integrate within the surrounding architecture.





5495

Ø 20 x 38 cm

Portable



5496

Ø 20 x 38 cm

Bolt-down



5497

Ø 20 x 38 cm

- 23 Warm White (NCS S 0502-Y50R)
- 25 Beige D1 (NCS S 4005-Y50R)
- 38 Terra Dark (NCS S 5040-Y70R)
- 47 Green L1 (NCS S 4005-G80Y)

Base and shade: ABS + PC- Polycarbonate
 Diffuser: PC- Polycarbonate
 Stem: Stainless steel

LED Colour Temperature

2700 K
 CRI>90

Control

Analog: On/ Off; Sensor; 1-10V
 Digital: DALI-2

Ref. 5495

Rechargeable battery autonomy:
 6h at 100% Intensity
 12h at 50% Intensity
 18h at 25% Intensity

Touch sensor 5495 and 5496



Rechargeable battery 5495

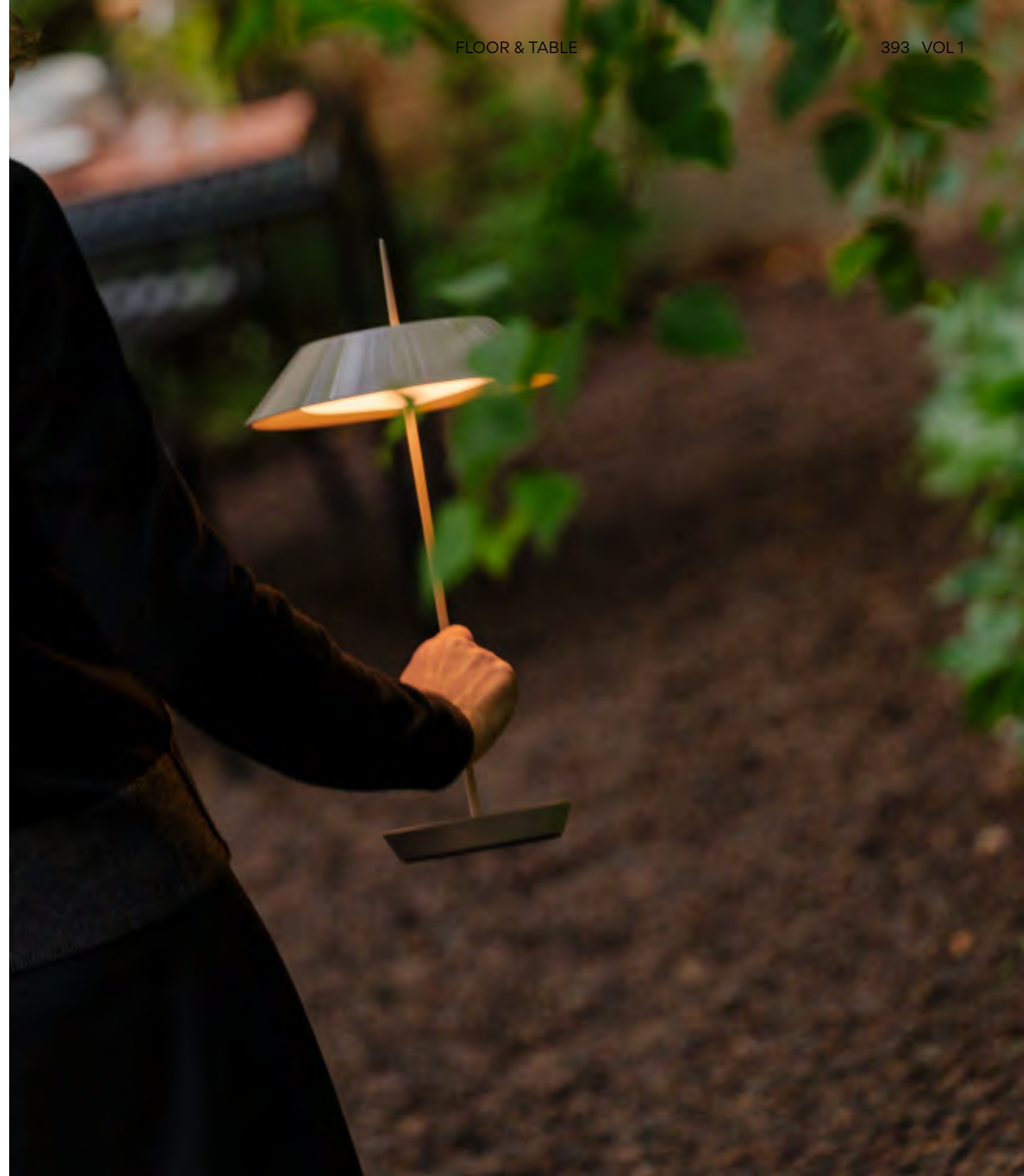

Mayfair



Design by Diego Fortunato.

A modern reimagining of the traditional 19th-century bouillotte lamp, the Mayfair collection is a statement in contemporary design. Perfectly proportioned, its luminaire casts a pool of diffuse, downward light to create an intimate lighting effect.



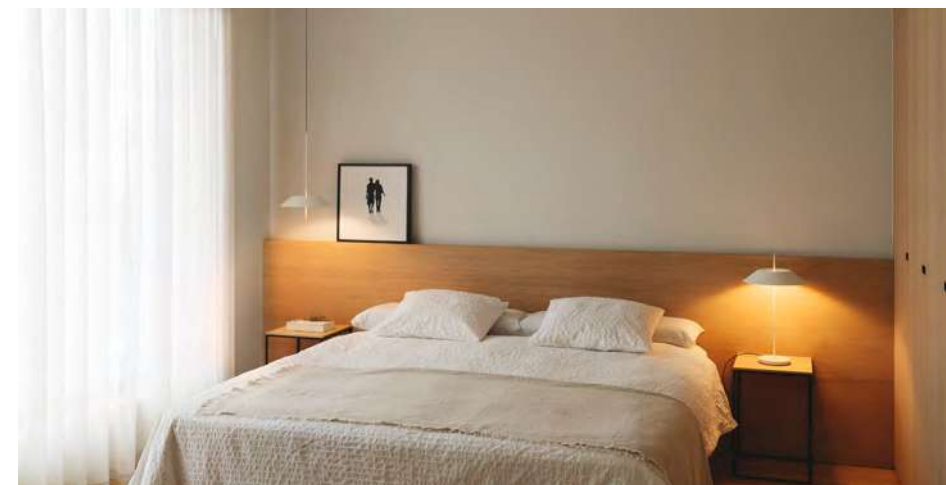



Featuring a steel column and steel or methacrylate shade, the LED-powered floor lamp casts an ambient glow that's ideal for a relaxed interior setting and can be dimmed via an optical sensor.

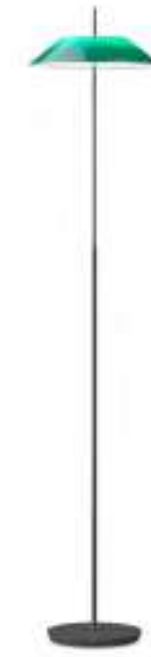
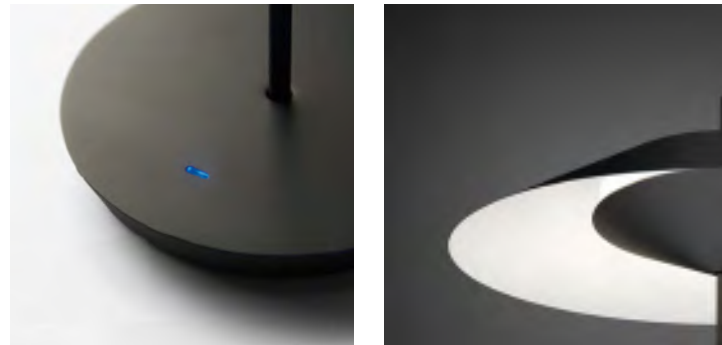

5510
Ø 30 x 147 cm



5500
Ø 30 x 52 cm



5515
Ø 30 x 147 cm



5505
Ø 30 x 52 cm

PMMA shade: Refs. 5500, 5510

- 07 Graphite and green (RAL 7016 and RAL 6026)
- 08 Graphite and orange (RAL 7016 and RAL 2009)

Steel shade: Refs. 5505, 5515

- 20 Gold (Gold)
- 67 Copper (Copper)

Colour shade: Refs. 5505, 5515

- 18 Graphite (RAL 7016)
- 23 Warm White (NCS S 0502-Y50R)
- 25 Beige D1 (NCS S 4005-Y50R)
- 38 Terra Dark (NCS S 5040-Y70R)
- 47 Green L1 (NCS S 4005-G80Y)

Finish customization
(Available options: Vibia colour palette)

Diffuser: PC- Polycarbonate
Tube: Steel
Base: Zinc Alloy

LED Colour Temperature
2700 K
CRI>90

Control
Analog: Optical sensor

Floor: Optical sensor on shade
Table: Optical sensor on base

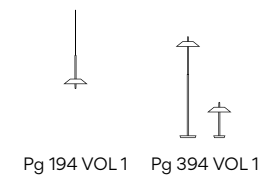

Pg 194 VOL1 Pg 394 VOL1

Balance

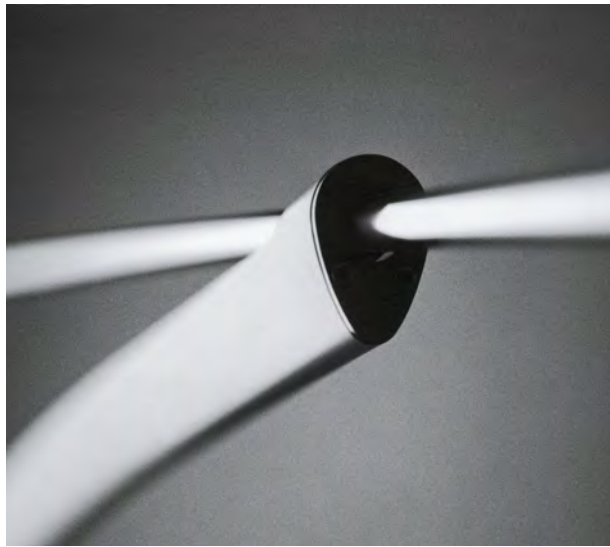

Design by Jordi Vilardell.

Balance features a classic drum shade, elegantly cantilevered from its column to provide a general ambient lighting effect or a more focused reading light.

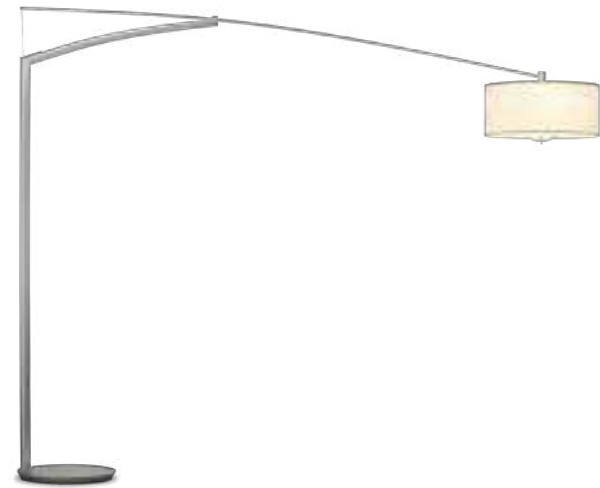

5189 5190

260 x 210 cm



5191 5192

215 x 210 cm

The Balance floor lamp serves multiple requirements simultaneously.

Illuminating a variety of spaces with its simple movement - it functions as a dining room lamp, an ambient living room light, or a reading lamp for work purposes.

Evoking the essence of its namesake, the drum shade is poised on a metal rod cantilevered from its steel column.

Adjusting a small pull piece on the diffuser activates the fixture's counterweight system, enabling it to move to the right or left, or up or down - all the while remaining parallel to the floor.

- 18 Graphite (RAL 7016)
- 30 Nickel (Metallic finish)

Shade: Parchment paper/ Aluminum
Vertical tube: Aluminum
Base: Steel
Arm: Stainless steel

LED Colour Temperature
2700 K

Control
Analog: Push



Flat

Design by Ichiro Iwasaki.

A study in geometry, the Flat collection features distinctive, disc-shaped diffusers that form horizontal planes of light, infusing a space with pools of soft illumination.







The LED-powered collection features flat metal plates reflecting light off their surface, casting an enveloping, wraparound glow that appears illuminated from within. The floor lamp comes in small and large sizes, with a single or double plate - either a compact disc or a shelf-like plate that doubles as furniture. When deployed in pairs, the smaller, complementary disc captures and reflects light back at the larger plate, creating pockets of soft, pooled indirect light that illuminate both the space and the surface itself.





5965
35 x Ø 30 x 16 cm



5970
29 x 17 x 30 cm



5972
11 x 30 cm

Bolt-down

Ref. 5945, 5957, 5965

- 13 Off-White (NCS S 1000-N)
- 47 Green L1 (NCS S 4005-G80Y)

Ref. 5950

- 10 White (NCS S 0300-N)

Ref. 5955, 5970, 5972

- 11 Black (NCS S 8500-N)
- 37 Terra Red (NCS S 4040-Y70R)
- 47 Green L1 (NCS S 4005-G80Y)

Shade: Aluminum
Diffuser: PC- Polycarbonate
Structures: Steel

LED Colour Temperature
2700 K; 3500 K
CRI>90

Control

Analog: Push

Ref. 5945

One general on/off and dimming switch for both discs



5945
76 x 64 x 90 cm



5950
Ø 55 x 43 cm

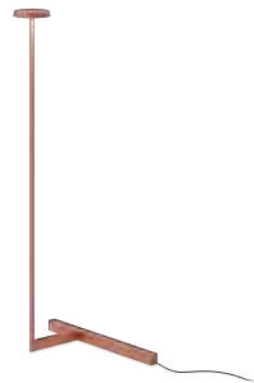

5955
46 x 25 x 100 cm



5957
48 x 35 x 96 cm

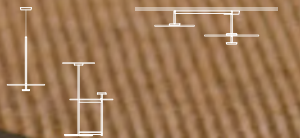

North



Design by Arik Levy.

North features a base, stem, and shade that are disconnected from one another in a dynamic system of adjustable parts. Protruding arms hold triangular shades that direct the light where needed.





The North Floor Pendant is defined by a dynamic, deconstructed silhouette. It synthesises the typical floor and pendant lamp by connecting floor and ceiling, its sleek conical shade hanging from a slender carbon fibre rod and secured by a counterweight at floor level. The angle of the rod is adjustable, allowing light to be directed precisely over a coffee table or sofa.

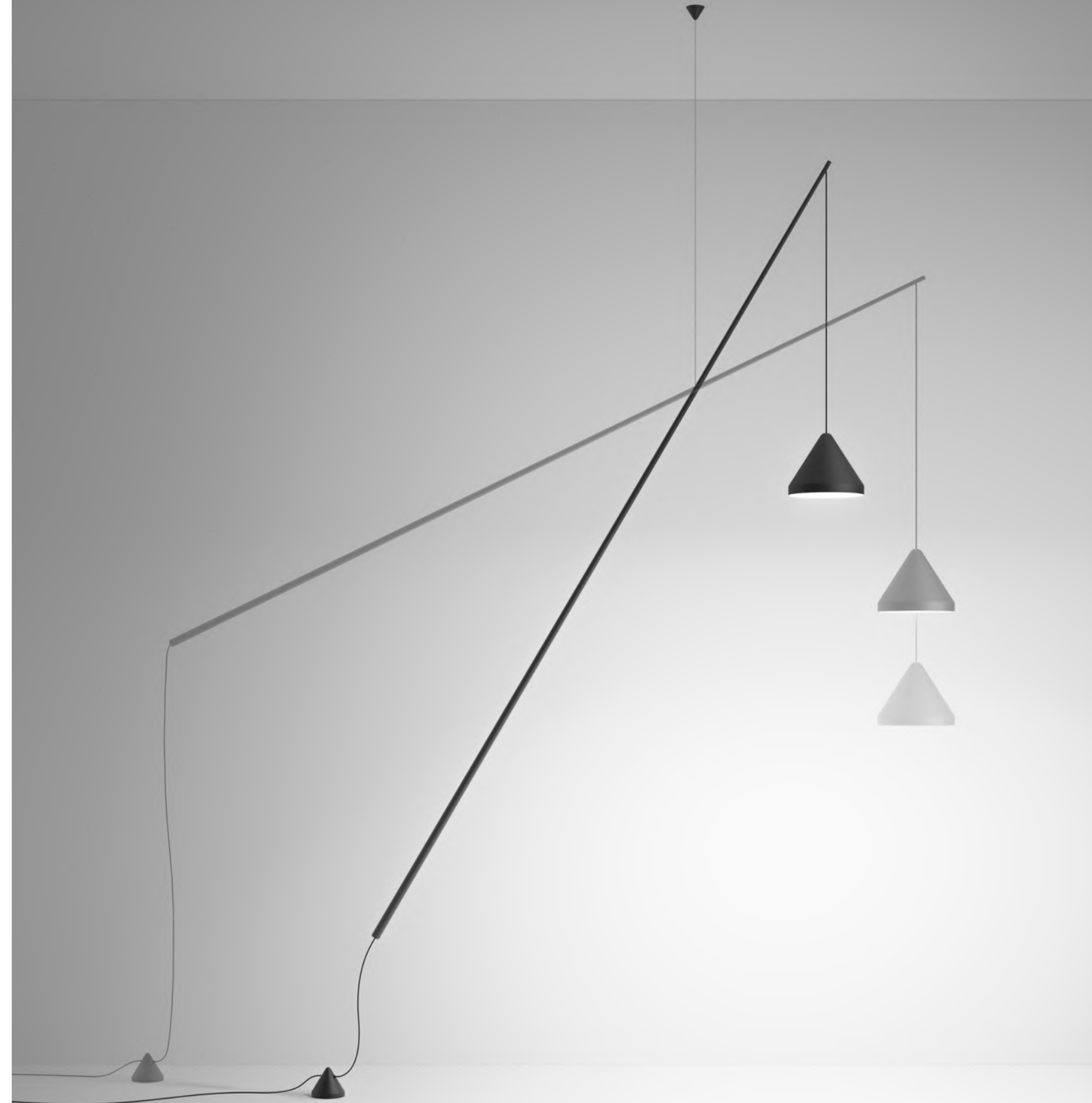



5666

max. 210 x max. 310 x max. 130 cm



5605

max. 270 x max. 230 x max. 355 cm



5620

max. 447 cm x max. 325 cm x max. 425 cm

- 10 White (NCS S 0300-N)
- 11 Black (NCS S 8500-N)
- 24 Beige M1 (NCS S 2005-Y50R)
- 42 Blue M1 (NCS S 5010-B10G)

Diffuser: PMMA
 Shade: Aluminum
 Rods: Carbon fiber
 Base: Steel

LED Colour Temperature

LED 2700 K: CRI>90
 LED 3000 K: CRI>80
 LED 3500 K: CRI>90

Control

Analog: Push

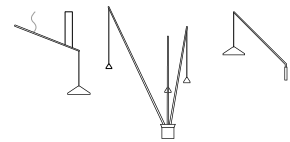

Pin



Design by Ichiro Iwasaki.

A timeless proposal from Japanese designer Ichiro Iwasaki, the Pin is both classic and contemporary. Characterised by a graceful stem and subtle, functional expression, it is small in scale but with exceptional lighting efficiency.





Slick, refined and understated, the Pin floor lamp is a state of the art design. Perfect for reading, its simple geometric form is designed to arc playfully over a sofa or chair.

Offering two arm lengths, a single or double stem and with an adjustable head, the Pin table lamp provides versatile task lighting that's ideal for work spaces.





- 11 Black (NCS S 8500-N)
- 23 Warm White (NCS S 0502-Y50R)
- 58 Cream (NCS S 2500-Y20R)
- 62 Green (NCS S 3010-G20Y)

LED Colour Temperature

2700 K
CRI>90

Control

Analog: On/ Off

Finish customization
(Available options: Vibia colour palette)

Diffuser: PC- Polycarbonate
Head: Aluminum
Rods: Steel
Base: Zinc Alloy



1650
23 x 55 cm

1655
40 x 55 cm

1660
25 x 125 cm

1670
35 x 143 cm

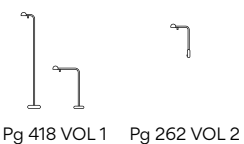

I.Cono



Design by Lievore, Altherr, Molina.

Distinguished by its signature visor-shaped shade, I.Cono presents a poised presence. The visual purity of its angular shade is matched by a sleek base and stem and complemented by a range of elegant finishes.



I.Cono's smooth surfaces and refined silhouette conceal advanced mechanisms for rotating the head and metal base, ideal for precision lighting and reading.





- 10 White (NCS S 0300-N)
- 21 Grey D1 (NCS S 7000-N)
- 25 Beige D1 (NCS S 4005-Y50R)
- 37 Terra Red (NCS S 4040-Y70R)
- 42 Blue M1 (NCS S 5010-B10G)

Shade: ABS + PC- Polycarbonate
 Tube: Metal
 Base: Zinc Alloy

LED Colour Temperature

2700 K
CRI>90

Control

Analog: Push
Smart: Casambi; ProtoPixel*

*ProtoPixel products are compatible with all other DALI-2 products via a designated gateway (please consult us)

On/off switch on the cable

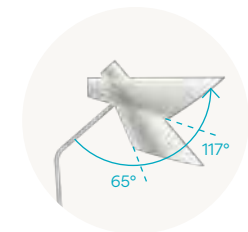

0712

21 x 129 x 35 cm



0700

17 x 56 x 32 cm



Suite



Design by Jordi Vilardell & Meritxell Vidal.

Suite reimagines the traditional pairing of shelf and lamp. The collection consists of a set of shelves and a table lamp, with invisible ambient illumination adding an unexpected surprise.





On/off switch under the shelf.
USB charging connection.

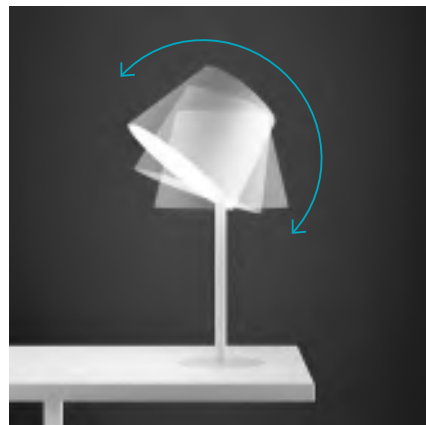

6007 and 6012.
Reading light Mink (Pantone 407C),
mounted on shelf with dimmable light.
Dimming push-button under the shelf.

- 14 Chocolate (RAL 8019)
- 23 Warm White (NCS S 0502-Y50R)

Finish customization
(Available options: Vibia colour palette)

Diffuser: PC- Polycarbonate
Shelf: Aluminum
Lid: ABS with fiberglass
Vertical tube: Steel
Base: Steel

LED Colour Temperature
2700 K
CRI>90

Control
Analog: Push



6006
46 x 46 x 133 cm



6007
46 x 46 x 133 cm



6011
46 x 39 x 97 cm



6012
46 x 39 x 112 cm

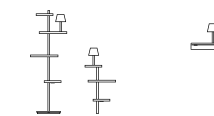

Skán



Design by Lievore, Altherr, Molina.

Skán is a sleek and unadorned fixture. It combines lean lines with soothing purity of form, adding a minimalist sensibility to any space.



Characterized by simple shapes that exude an unmistakable elegance, the Skan floor lamp features flat, disc-like shades which emit a diffuse, comfortable uplight. Three slender stems are entwined like a group of trees, the body and head available in various contemporary matte finishes.

- 10 White (NCS S 0300-N)
- 11 Black (NCS S 8500-N)
- 37 Terra Red (NCS S 4040-Y70R)

Finish customization
(Available options: Vibia colour palette)

Head: Aluminum
Diffuser: PMMA
Vertical tube: Steel

LED Colour Temperature
2700 K; 3000 K; 3500 K
CRI>90

Control
Analog: Push



0260

43 x 37,5 x 198 cm

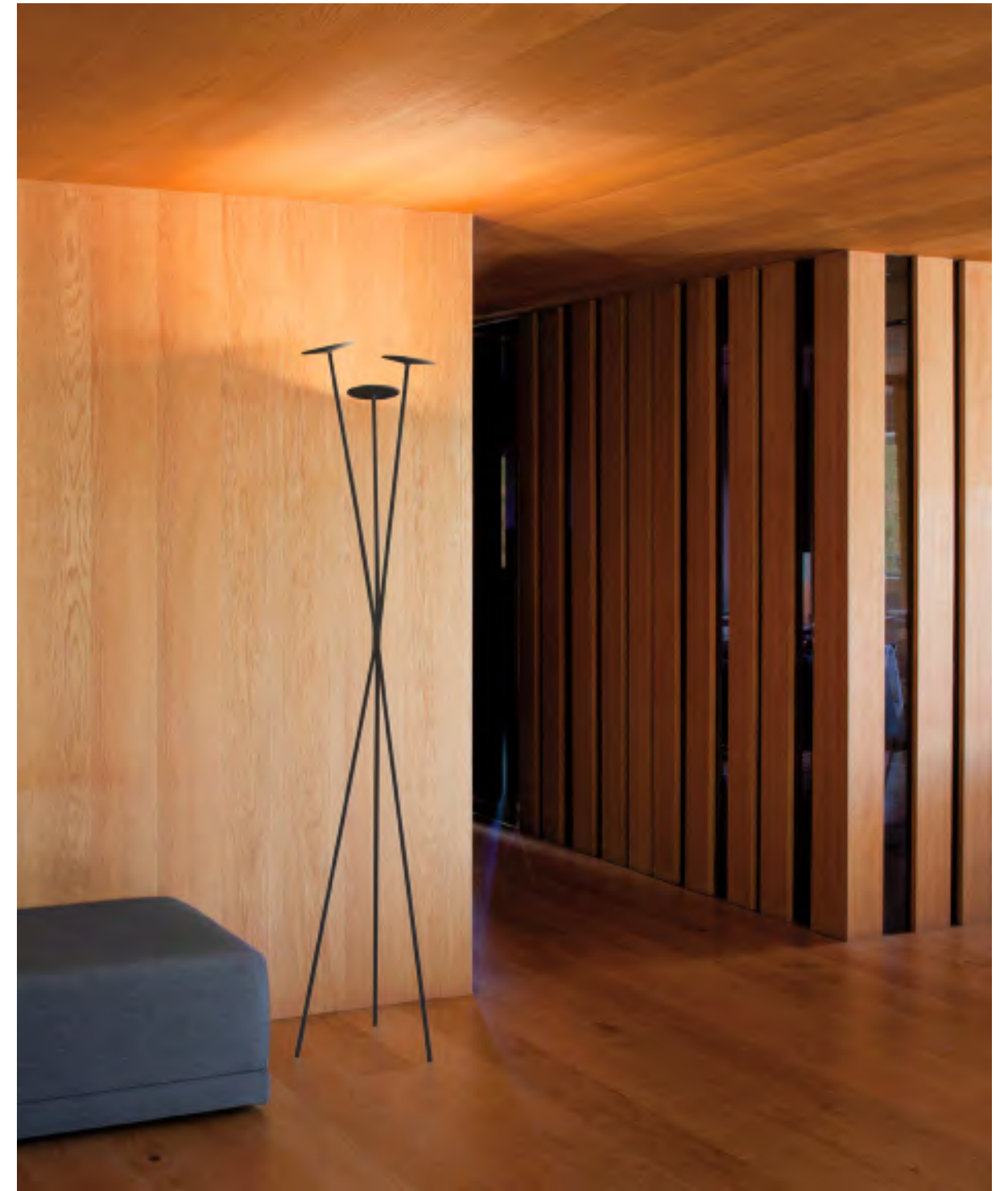

Ghost



Design by Arik Levy.

A study in contrasts, the Ghost collection embodies both spirit and materiality, discretion and presence. A contemporary reimagining of the grand lights that once graced entryways and living areas, its sensuous form radiates with a warm, welcoming glow.



The Ghost table lamp features a stacked silhouette of voluminous forms to offer an enveloping luminous effect. A black band encircles the midsection, accentuating its sensuous curves while serving as a hand-touch dimmer.

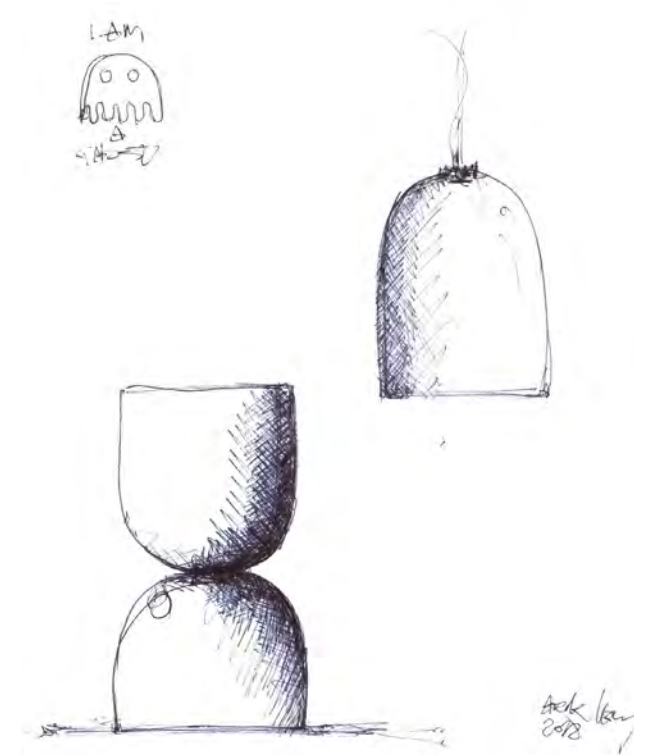

“Ghost is the pure expression of a state of mind, of the immateriality of mouthblown glass that projects a sensuous halo in space”.

Arik Levy



4960
Ø 47,5 x 112 cm



4965
Ø 47,5 x 92 cm



4970
Ø 47,5 x 88 cm

● 11 Black (NCS S 8500-N)

Diffuser: Opal Glass
Metal parts: Aluminum

LED Colour Temperature

2700 K
CRI>90

Control

Analog: Push; 1-10V
Digital: DALI-2
Smart: Casambi



/_ 5: Push-dimming model equipped with two buttons, one for each diffuser. A quick push turns the light on and off, a longer presson dims the light.

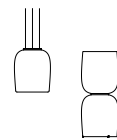

Pg 90/438 VOL 1

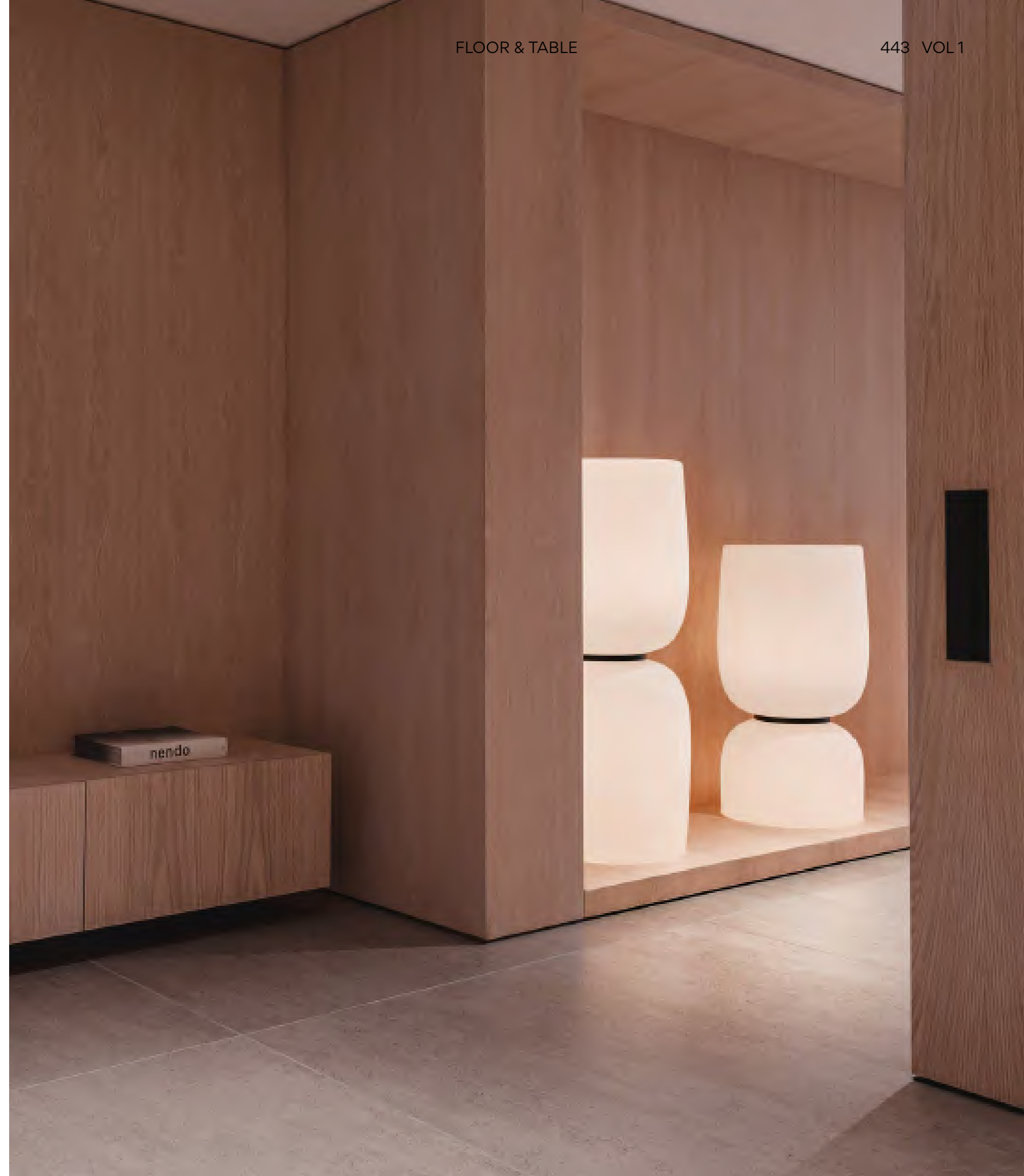

Jazz

Design by Diego Fortunato.

Undulating and fluid, Jazz's smooth silhouette is strikingly organic. The gently curved design imparts a playful presence, like an oversized chess piece standing guard.





1329
 Ø 25 x 190 cm

- 10 White (NCS S 0300-N)
- 25 Beige D1 (NCS S 4005-Y50R)
- 45 Blue D1 (NCS S 7010-B10G)

Body: PU- Polyurethane
 Diffuser: PC- Polycarbonate

LED Colour Temperature

LED 2700 K
 CRI>90

Control

Analog: Push
 Smart: Casambi; ProtoPixel*

*ProtoPixel products are compatible with all other DALI-2 products via a designated gateway (please consult us)



Floor switch

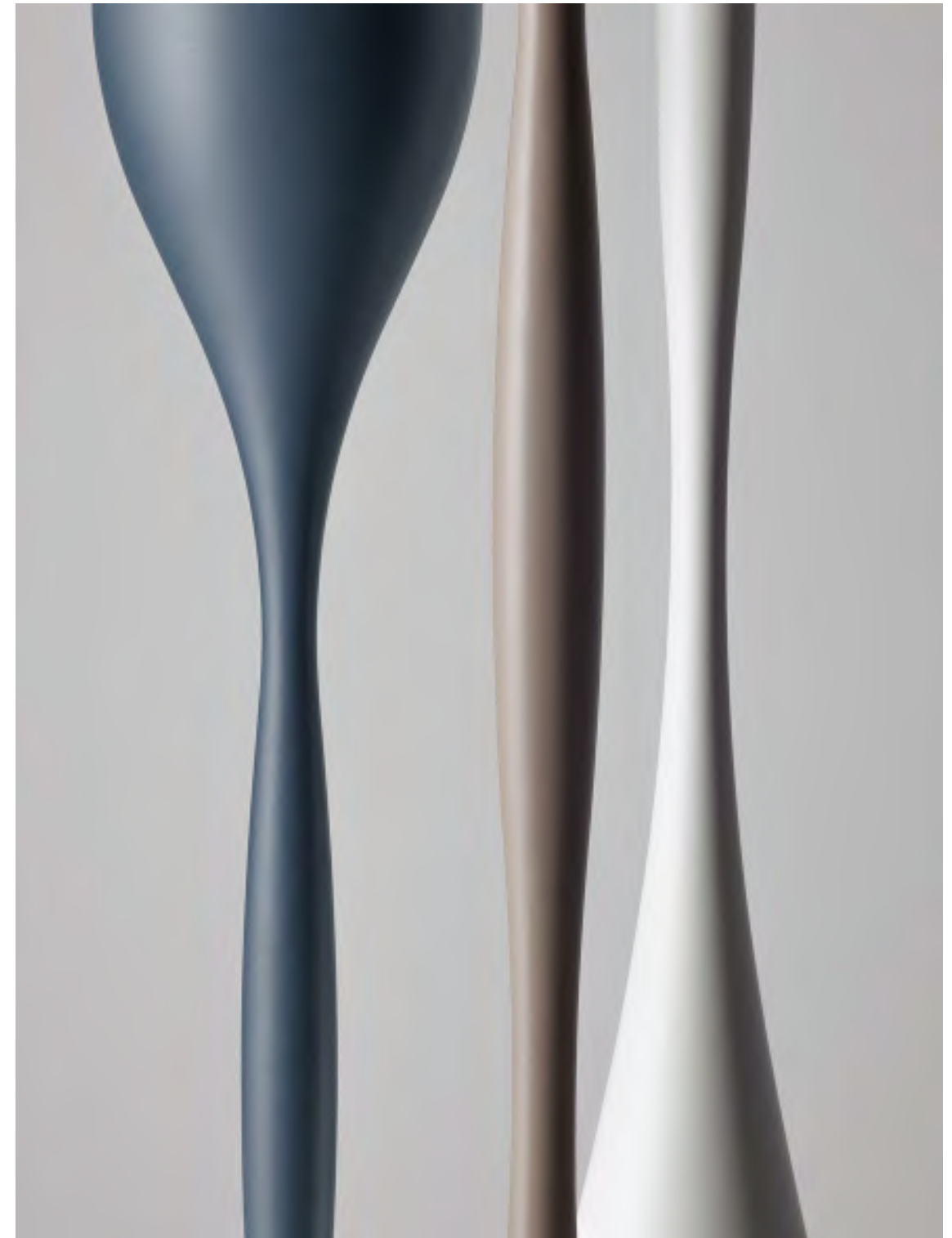

Warm

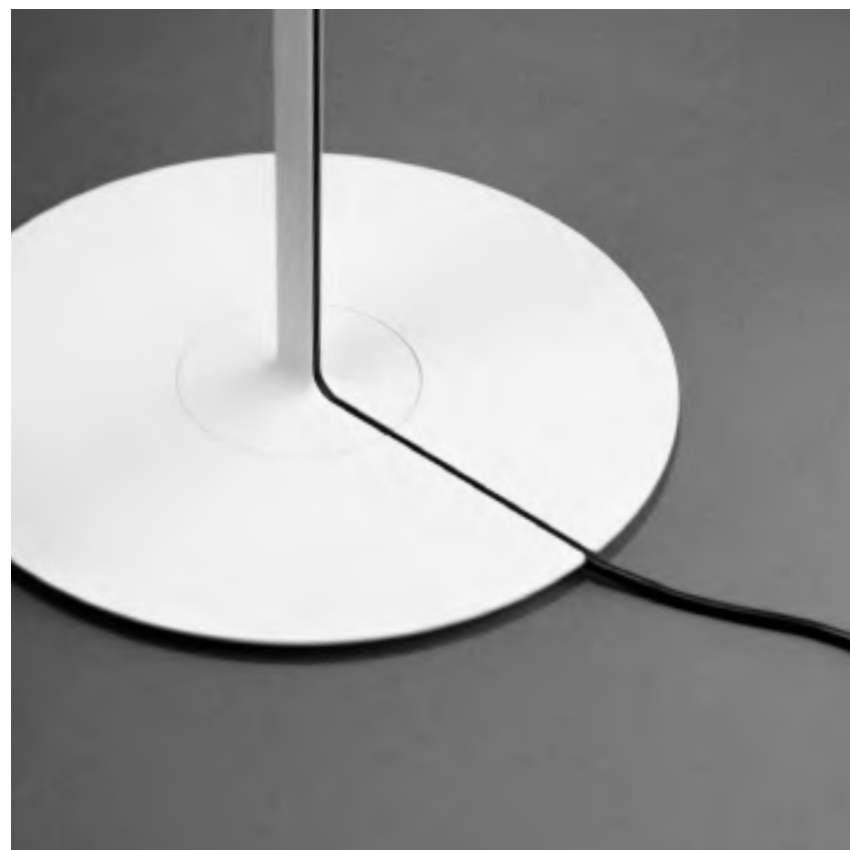

Design by Ramos & Bassols.

A contemporary take on a timeless design, Warm features a generous drum shade in a muted colour palette for a refined touch.



Bringing a touch of elegance that's adaptable to any atmosphere, Warm is available in two models: the translucent screen provides general ambient illumination and the opaque aluminium shade offers a brighter, up- and downlight.

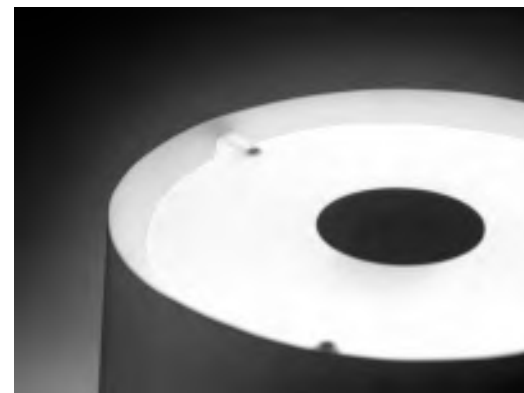



4895 4896
Ø 19 x 41 cm



4900 4901
Ø 32,4 x 59 cm



4905 4906
Ø 32,4 x 150 cm

Screen shade: Ref. 4895, 4900, 4905

● 10 White (NCS S 0300-N)

Aluminum shade: Ref. 4896, 4901, 4906

● 10 White (NCS S 0300-N)

● 25 Beige D1 (NCS S 4005-Y50R)

● 28 Brown M1 (NCS S 4020-Y60R)

● 56 Green D1 (NCS S 7010-G30Y)

Finish customization

(Available options: Vibia colour palette)

Diffuser: PMMA

Rod: Aluminum

Base: Steel

LED Colour Temperature

2700 K

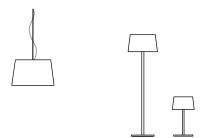

Pg 122 VOL 1 Pg 448 VOL 1



Musa

Design by Note Design Studio.

A poetic lighting solution, Musa is inspired by the beauty of nature. Its delicate silhouette consists of two ovals: a milky-white blown-glass shade and an LED-powered bulb cradled within.



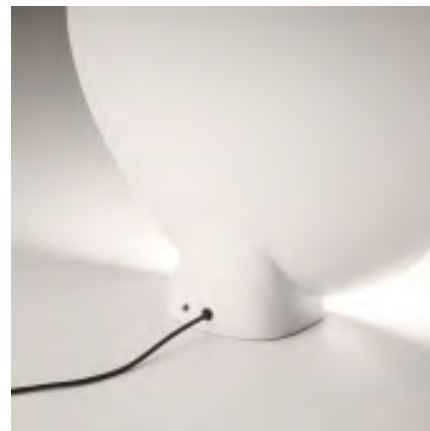

Refs. 7400, 7402.
Electric cable with plug.
Push-button on the base.



Ref. 7404.
Portable version with battery.
Electric cable with plug.
Push-button on the base.

**7400**

9 x Ø 26 cm

**7402 7404**

Ø 26 x 14 x 10 cm

As a table lamp, its smooth bowl rests on an aluminium base that's tucked behind the body so as not to disrupt the design. A small, dimmable bulb nestles at its base, casting a soft glow that spreads across the larger sphere which contains and diffuses it.

- 23 Warm White (NCS S 0502-Y50R)
- 24 Beige M1 (NCS S 2005-Y50R)
- 36 Soft Pink (NCS S 1010-Y50R)

Finish customization
(Available options: Vibia colour palette)

Diffuser: Blown-glass
Body: Aluminium

LED Colour Temperature

2700 K
CRI>90

Control

Analog: Push

Ref: 7404

Portable

Battery life: from 6 to 18 hours
(depending on intensity)



Offset



Design by Xuclà.

Offset consists of a vertical rod extending from a solid base. The rod can be angled to illuminate an adjacent wall with a diffuse, ambient lighting effect. A combination of multiple fixtures of different lengths adds a graphic dimension to a contemporary interior.





Never harsh or obvious, these are thoughtful, ultra-nuanced colours that respect and reflect the characteristics of natural light while capturing or enhancing a desired mood or moment. Applicable to day and night and every hour in between, each hue has an adaptable tone that can be tailored to any scenario or space.

Whatever the situation, these are illuminating tones that set the stage for life in all its colourful complexity.

A source of emotion

Colour is a source of emotion it can instantly set a mood, convey a feeling or generate a sense of wellbeing

Vibia's approach to coloured light invites the use of colour and gradients to create and experience different atmospheres, making them as natural and subtle as possible. Natural light is never mono-tonal. Gradients come in infinite colours.

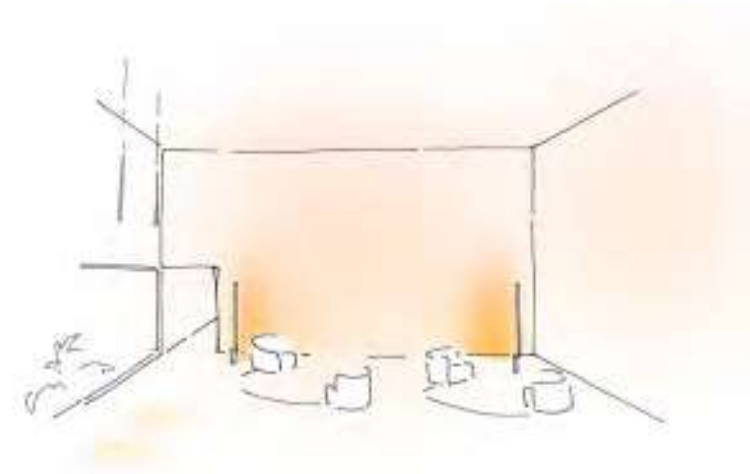

Vibia Chromatica colours of light

Static White

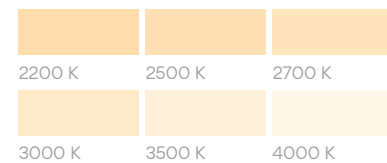

You can select any desired light -white, colour mood or gradient- and intensity manually from the analogic product interface. You can also integrate your selection into the control system for specific scene design and activate it using the Vibia App

Colour Moods

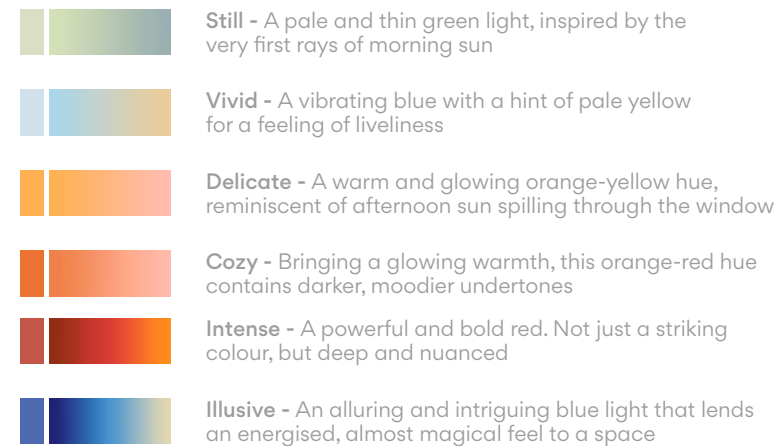

Contact Vibia Support Service at vibia.com for any kind of assistance or recommendation when designing an atmosphere of wellbeing, or if you require support with control system approach.

Delicate colour mood

A warm and glowing orange-yellow hue, reminiscent of afternoon sun spilling through the window. Golden tones from apricot pink to soft orange meet in the gradient.

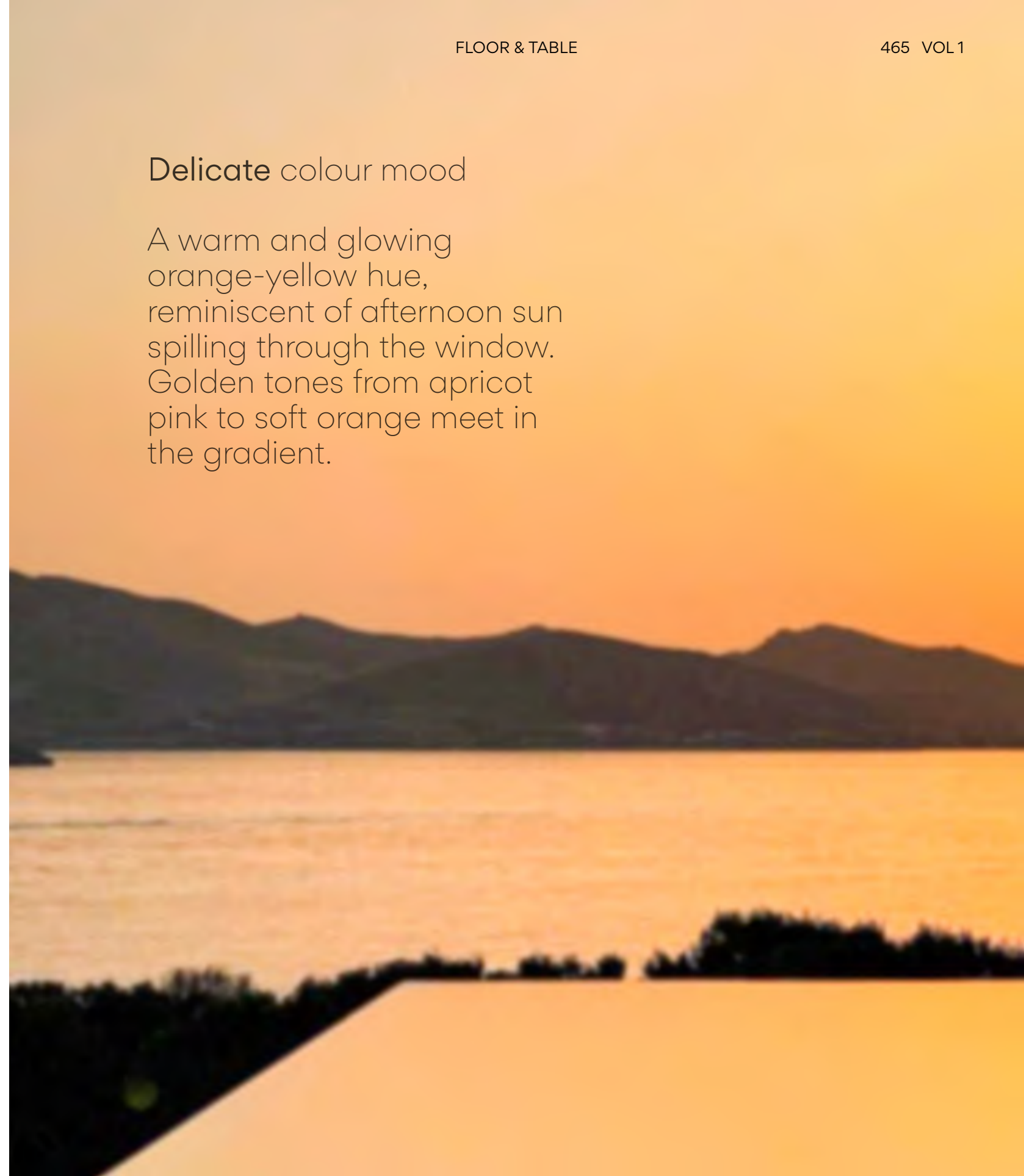

Colour Mood Grazer

- 11 Black (NCS S 8500-N)
- 23 Warm White (NCS S 0502-Y50R)
- 24 Beige M1 (NCS S 2005-Y50R)

Body: Aluminum
Lens: PMMA

LED Colour Temperature

Infinite Colour (TW + RGB)
CRI >90

Control

Smart: ProtoPixel*
(also with push buttons)

*ProtoPixel products are compatible with all other DALI-2 products via a designated gateway (please consult us)

You can select any desired light -white, colour mood or gradient- and intensity manually from the analogic product interface

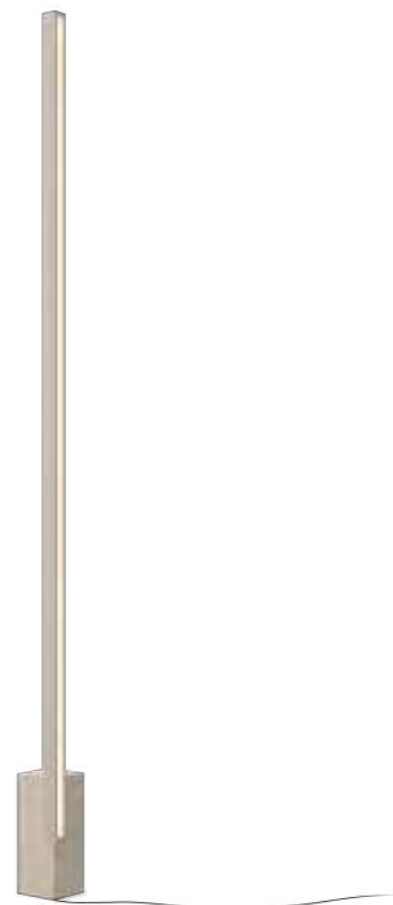
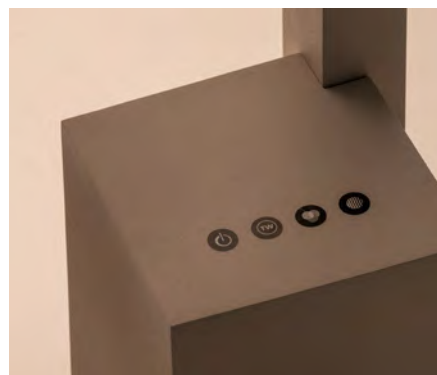

1780

14 x 128 cm



Pg 460 VOL 1 Pg 94/348 VOL 2



Out



Design by Víctor Carrasco.

A romantic response to the global transition to life outside, Out brings the intimacy of indoor lighting outdoors. Suitable for illuminating a table or meeting point, this luminaire emanates with a soft, diffuse downlight.





4270 Not Fixed
211 x 242 cm



4275 Bolt-down "hard wired"
211 x 242 cm

- 22 Graphite Black (NCS S 8000-N)
- 23 Warm White (NCS S 0502-Y50R)
- 25 Beige D1 (NCS S 4005-Y50R)
- 36 Soft Pink (NCS S 1010-Y50R)
- 37 Terra Red (NCS S 4040-Y70R)
- 47 Green L1 (NCS S 4005-G80Y)

Tube: Stainless Steel
Shade: Aluminum
Diffuser: PE- Polyethylene

LED Colour Temperature
2700 K
CRI>90

Control
Ref. 4270
Analog: Push
Smart: Casambi; ProtoPixel*
*ProtoPixel products are compatible with all other DALI-2 products via a designated gateway (please consult us)
Ref. 4275
Digital: DALI-2
Smart: Casambi (Remote)

4270. Cable with switch **IP44**



IP65

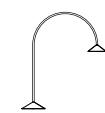

Plusminus Solo

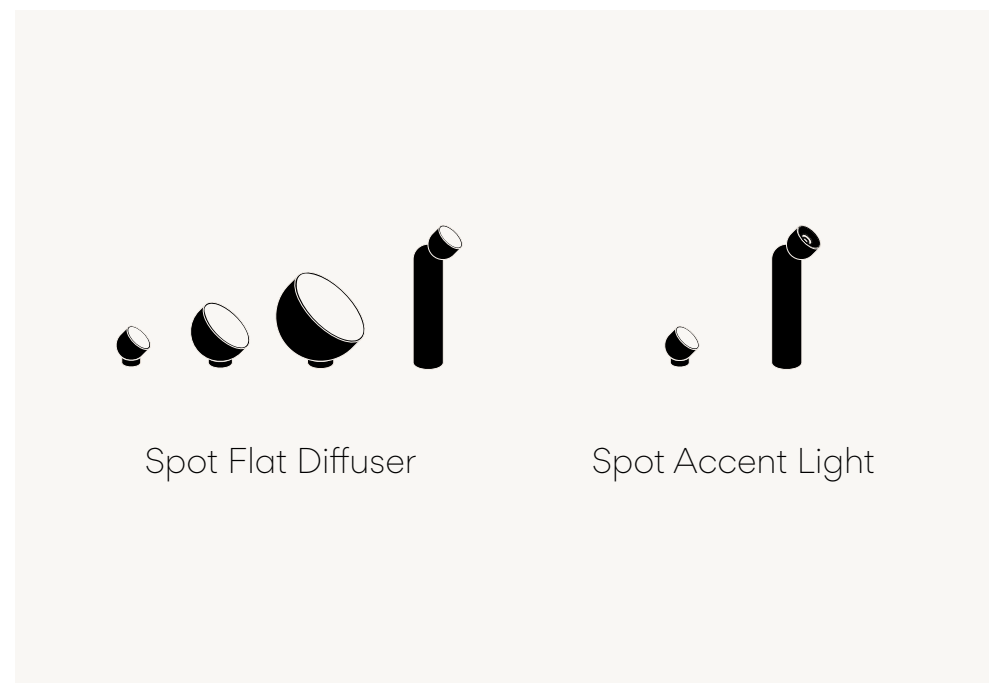

Design by Diez Office.

Introducing a collection of versatile semispheres, Plusminus Solo offers complete freedom to create dynamic and restorative atmospheres. A combination of various typologies unlocks harmonious effects, from diffuse and general through to accented lighting.





Table switch







Floor switch



Plusminus Solo offers two distinct designs, visually connected by their signature semi-spherical shades. A range of dome-shaped flat diffusers can be positioned as desired, directed upwards from floor level or tilted at an angle.

A compact floor or table lamp completes the set. With a thick cylindrical base and adjustable shade, this portable model provides accent or diffuse spotlighting wherever needed.



6341 Surface Accent medium
6343 Surface Flat diffuser

Ø 10 x 50 cm

6346 Bolt-down Accent medium
6348 Bolt-down Flat diffuser

Ø 10 x 50 cm

- 11 Black (NCS S 8500-N)
- 24 Beige M1 (NCS S 2005-Y50R)
- 37 Terra Red (NCS S 4040-Y70R)
- 42 Blue M1 (NCS S 5010-B10G)
- 53 Green M1 (NCS S 6005-G80Y)

Body: Aluminum
 Base: Steel / Zinc Alloy
 Diffuser: PC- Polycarbonate

LED Colour Temperature
 2700 K; 3000 K; 3500 K
 CRI>90

Control
 Analog: Push
 Digital: DALI-2 (Bolt-down)
 Smart: Casambi; ProtoPixel*
 *ProtoPixel products are compatible with all other DALI-2 products via a designated gateway (please consult us)



6361
 Surface / Bolt-down
 Accent medium

6363
 Surface / Bolt-down
 Flat diffuser

Ø 10 x 10 cm



6365
 Surface / Bolt-down
 Flat diffuser

Ø 20 x 14 cm



6370
 Surface / Bolt-down
 Flat diffuser

Ø 30 x 20 cm



Pg 472 VOL 1 Pg 120/216 VOL 2





Lighting Typologies

Support Portfolio

Lighting Typologies

Diffuse



Flat Diffuser

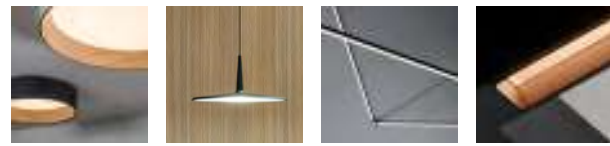

General Proximity Linear Linear High Comfort

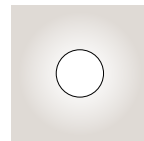

Volumetric Diffuser

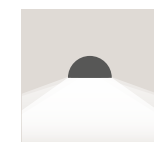

Hidden Diffuser

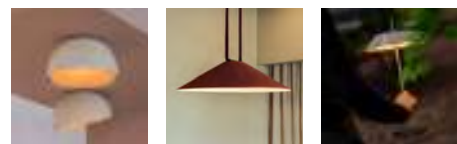

General Proximity

Indirect

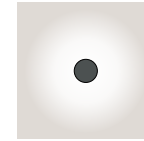

Reflected

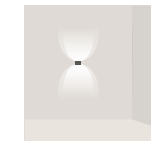
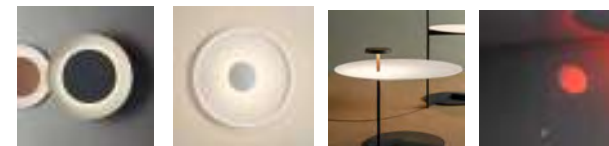

Surface Grazer

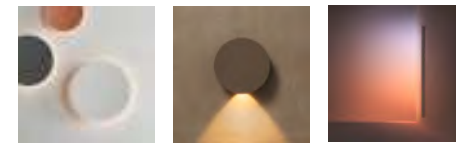

360° Direct Mood Grazer



Wall Washer

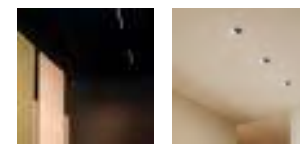

Linear Spot

Direct



Spotlight

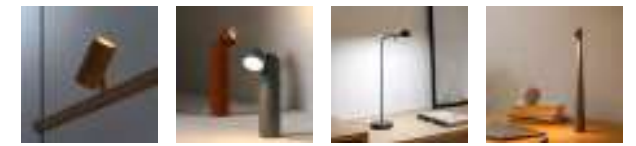

Accent Reading



Downlight



Accent



Linear High Efficiency Low Glare



Lighting Typologies

Diffuse

Flat Diffuser



Comfortable, uniform illumination with soft shadows, subdued highlights and little visual hierarchy



General
First layer of basic, general illumination

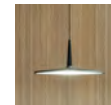

Close Proximity
Lighting applications for illumination in close proximity to the user



Linear
Linear lighting applications for functional and graphic illumination



Linear High Comfort
Linear lighting applications with High lighting and comfort levels (UGR <19) for illumination in close proximity

Volumetric Diffuser

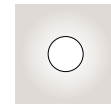

Subtly directed, diffused light that generates a soft hierarchy of light on to the illuminated surface.



Hidden Diffuser

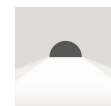

Subtly directed diffused light that generates a soft hierarchy of light on to the illuminated surface



General
First layer of basic, general illumination

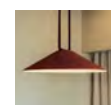

Close Proximity
Lighting applications for illumination in close proximity to the user

Indirect

Reflected



Creation of visual hierarchies within the luminaire itself, emphasising the materiality and texture of the product

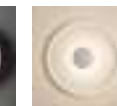

Surface Grazer



Creation of visual hierarchies through projected light, emphasising the materiality and texture of the surrounding environment



360°
Full-circle grazing light



Direct
Directed grazing light



Mood Grazer
Tunable white or infinite colour regulation to curate the perfect atmosphere

Wall Washer



Vertical lighting to give structure and amplitude to a space. Diffuse light is reflected from the illuminated surface for a soft and homogeneous atmosphere

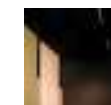

Linear
Bathing a vertical surface with light projected from a linear lighting application



Spot
Bathing a vertical surface with light projected from a spot lighting application

Direct

Spotlight



Adjustable, directed light for dynamic visual hierarchies, emphasising functional areas, objects or architectural elements



Accent
Narrow: Angles less than 20°. Suitable for generating high contrasts or projections at far distances.
Medium: Angles between 20° and 40°. Suitable for generating medium contrasts or projections at medium distances.
Wide: Angles greater than 40°. Suitable for generating moderate contrasts or projections at near distances.

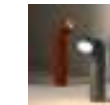

Reading
High intensity, glare-free task lighting

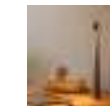

Downlight



Static, directed light for creating visual hierarchies and emphasising functional areas, objects or architectural elements



Accent
Narrow: Angles less than 20°. Suitable for generating high contrasts or projections at far distances.
Medium: Angles between 20° and 40°. Suitable for generating medium contrasts or projections at medium distances.
Wide: Angles greater than 40°. Suitable for generating moderate contrasts or projections at near distances.

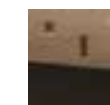

Linear High Efficiency Low Glare



High energy efficiency and low glare levels UGR<19 for linear light applications

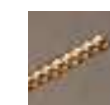

Support Portfolio



From Project Support to Usage

To achieve wellbeing scenes it is necessary to cover the entire end-to-end journey. From **design** and composition through to **installation** and **user interaction**, Vibia's team is prepared to assist you in any request you may have.

Sales Team Project Support

Direct contact with the Vibia representative in your area to assist you with whatever you need.

Selection of the appropriate product and customisation.

Creation of project moodboards by scenes.

Use of Vibia's online professional tools (Website, App, etc.).



Lighting & Wellbeing Studio

Vibia's specialised team is at your disposal to assist you in creating a complete Atmosphere Design project, including:

Scenes design.

Optional:

Lighting calculations, renderings, etc.

Control system approach.

End-user interaction approach.



Lighting Project Design with Scenes

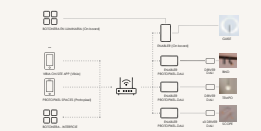

Control System and End-User Interaction Approach

Technical Support Services (TSS)

Our technical service team is available to assist you with any post-sales queries you may have, including:

Installation process.

Control System implementation process.

Maintenance.

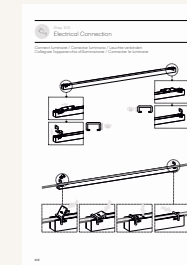

Installation and Maintenance Process

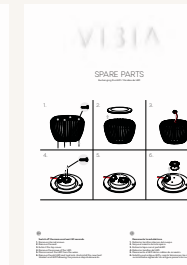

Control System Implementation

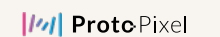

Online Professional Tools

Support for our digital tools designed for professionals.

Web: Professional Area.

Onsite App.



Web Project Management Area

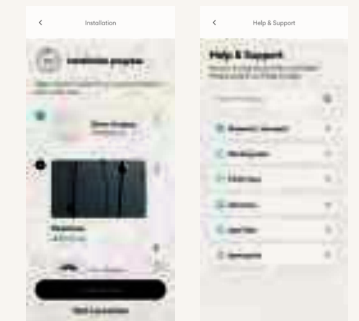

Onsite App

Atmosphere Design Content and Professional Training

Consult about Vibia's training program.

New Approach to Atmospheres Design:

Periodic online training sessions.

In-company training.

Certification Programs: COMING SOON.

Certificate in Emotional Atmosphere Design for project designers.

Certificate for Vibia Authorised Installers to provide local support.



Events for professionals

| Model | Vol Page | Model | Vol Page | Model | Vol Page | Model | Vol Page | Model | Vol Page | Model | Vol Page | Model | Vol Page | Model | Vol Page |
|-------|---------------------|-------|----------------|-------|-----------------|-------|---------------|-------|-----------------------|-------|-----------------------|-------|-----------------|-------|-----------------|
| 0130 | Vol 1 53 | 0825 | Vol 1 210 | 1747 | Vol 2 108 | 2340 | Vol 1 220 | 3510 | Vol 2 80 | 4078 | Vol 1 232 - Vol 2 428 | 4820 | Vol 2 421 | 5585 | Vol 1 362 |
| 0131 | Vol 1 53 | 0827 | Vol 1 210 | 1755 | Vol 2 104 | 2341 | Vol 1 220 | 3513 | Vol 2 80 | 4101 | Vol 2 432 | 4870 | Vol 2 11 | 5590 | Vol 1 362 |
| 0132 | Vol 1 53 | 0830 | Vol 1 210 | 1757 | Vol 2 104 | 2342 | Vol 1 220 | 3515 | Vol 2 80 | 4106 | Vol 2 432 | 4871 | Vol 2 17 | 5595 | Vol 1 362 |
| 0135 | Vol 2 59 | 0832 | Vol 1 210 | 1760 | Vol 2 112 - 353 | 2343 | Vol 1 220 | 3518 | Vol 2 80 | 4108 | Vol 2 432 | 4872 | Vol 2 11 | 5605 | Vol 1 416 |
| 0136 | Vol 2 59 | 0835 | Vol 1 210 | 1762 | Vol 2 112 - 353 | 2350 | Vol 1 226 | 3530 | Vol 2 84 | 4112 | Vol 2 443 | 4873 | Vol 2 17 | 5620 | Vol 1 416 |
| 0137 | Vol 2 59 | 0837 | Vol 1 210 | 1765 | Vol 2 112 - 353 | 2351 | Vol 1 226 | 3533 | Vol 2 84 | 4114 | Vol 2 443 | 4874 | Vol 2 11 | 5630 | Vol 2 333 |
| 0140 | Vol 1 53 - Vol 2 59 | 0840 | Vol 1 210 | 1767 | Vol 2 112 - 353 | 2355 | Vol 1 228 | 3535 | Vol 2 84 | 4116 | Vol 2 443 | 4875 | Vol 2 17 | 5660 | Vol 1 266 |
| 0141 | Vol 1 53 - Vol 2 59 | 0845 | Vol 1 210 | 1770 | Vol 2 352 | 2356 | Vol 1 228 | 3538 | Vol 2 84 | 4118 | Vol 2 443 | 4876 | Vol 2 11 | 5662 | Vol 1 266 |
| 0142 | Vol 1 53 - Vol 2 59 | 0847 | Vol 1 210 | 1772 | Vol 2 352 | 2360 | Vol 2 338 | 3540 | Vol 2 84 | 4125 | Vol 2 410 | 4877 | Vol 2 17 | 5664 | Vol 1 266 |
| 0151 | Vol 1 53 - Vol 2 59 | 0850 | Vol 1 210 | 1774 | Vol 2 352 | 2500 | Vol 1 164 | 3543 | Vol 2 84 | 4130 | Vol 2 410 | 4878 | Vol 2 11 | 5666 | Vol 1 416 |
| 0152 | Vol 1 53 - Vol 2 59 | 0860 | Vol 1 210 | 1780 | Vol 1 466 | 2501 | Vol 1 164 | 3550 | Vol 2 86 | 4135 | Vol 2 410 | 4879 | Vol 2 17 | 5670 | Vol 1 266 |
| 0153 | Vol 1 53 - Vol 2 59 | 0862 | Vol 1 210 | 1800 | Vol 1 12 | 2502 | Vol 1 164 | 3553 | Vol 2 86 | 4136 | Vol 2 410 | 4880 | Vol 2 11 | 5672 | Vol 1 266 |
| 0155 | Vol 1 52 - Vol 2 58 | 0865 | Vol 1 210 | 1805 | Vol 1 12 | 2510 | Vol 1 164 | 3555 | Vol 2 86 | 4270 | Vol 1 471 - Vol 2 387 | 4881 | Vol 2 17 | 5674 | Vol 1 266 |
| 0157 | Vol 1 52 - Vol 2 58 | 0867 | Vol 1 210 | 1810 | Vol 1 12 | 2511 | Vol 1 164 | 3558 | Vol 2 86 | 4275 | Vol 1 471 - Vol 2 387 | 4895 | Vol 1 452 | 5720 | Vol 1 377 |
| 0162 | Vol 1 52 - Vol 2 58 | 0870 | Vol 1 210 | 1815 | Vol 1 12 | 2515 | Vol 1 164 | 3560 | Vol 2 86 | 4440 | Vol 2 190 | 4896 | Vol 1 452 | 5725 | Vol 1 377 |
| 0164 | Vol 1 52 - Vol 2 58 | 0872 | Vol 1 210 | 1820 | Vol 1 12 | 2516 | Vol 1 164 | 3563 | Vol 2 86 | 4442 | Vol 2 190 | 4900 | Vol 1 452 | 5730 | Vol 1 18 |
| 0167 | Vol 1 52 - Vol 2 58 | 0875 | Vol 1 210 | 1825 | Vol 1 12 | 2600 | Vol 2 273 | 3565 | Vol 2 86 | 4452 | Vol 2 190 | 4901 | Vol 1 452 | 5756 | Vol 2 231 |
| 0171 | Vol 2 66 | 0877 | Vol 1 210 | 1830 | Vol 1 12 | 2602 | Vol 2 273 | 3568 | Vol 2 86 | 4454 | Vol 2 190 | 4905 | Vol 1 452 | 5757 | Vol 2 231 |
| 0172 | Vol 2 66 | 0920 | Vol 1 216 | 1835 | Vol 1 12 | 2610 | Vol 2 273 | 3575 | Vol 2 88 | 4460 | Vol 2 190 | 4906 | Vol 1 452 | 5758 | Vol 2 231 |
| 0173 | Vol 2 66 | 1154 | Vol 2 215 | 1840 | Vol 1 12 | 2612 | Vol 2 273 | 3578 | Vol 2 88 | 4500 | Vol 2 315 - 392 | 4925 | Vol 1 125 | 5759 | Vol 2 231 |
| 0176 | Vol 1 64 | 1155 | Vol 2 215 | 1845 | Vol 1 12 | 2615 | Vol 2 273 | 3580 | Vol 2 88 | 4501 | Vol 2 315 - 392 | 4926 | Vol 1 125 | 5760 | Vol 2 231 |
| 0177 | Vol 1 64 | 1160 | Vol 2 41 - 215 | 1850 | Vol 1 13 | 2617 | Vol 2 273 | 3583 | Vol 2 88 | 4504 | Vol 2 315 - 392 | 4960 | Vol 1 442 | 5761 | Vol 2 231 |
| 0178 | Vol 1 64 | 1170 | Vol 2 41 - 215 | 1855 | Vol 1 13 | 2630 | Vol 2 180 | 3585 | Vol 2 88 | 4506 | Vol 2 315 - 392 | 4965 | Vol 1 442 | 5762 | Vol 2 231 |
| 0182 | Vol 1 62 | 1510 | Vol 1 158 | 1860 | Vol 1 13 | 2632 | Vol 2 180 | 3588 | Vol 2 88 | 4508 | Vol 2 315 - 392 | 4970 | Vol 1 442 | 5763 | Vol 2 231 |
| 0185 | Vol 1 62 | 1527 | Vol 1 158 | 1865 | Vol 1 13 | 2634 | Vol 2 180 | 3605 | Vol 2 90 | 4510 | Vol 2 400 | 4987 | Vol 1 92 | 5764 | Vol 2 231 |
| 0187 | Vol 1 62 | 1530 | Vol 1 158 | 1870 | Vol 1 13 | 2640 | Vol 2 180 | 3608 | Vol 2 90 | 4516 | Vol 2 400 | 5189 | Vol 1 402 | 5765 | Vol 2 231 |
| 0193 | Vol 1 63 | 1540 | Vol 1 159 | 1875 | Vol 1 13 | 2642 | Vol 2 180 | 3610 | Vol 2 90 | 4539 | Vol 2 400 | 5190 | Vol 1 402 | 5766 | Vol 2 231 |
| 0196 | Vol 1 63 | 1550 | Vol 1 159 | 1880 | Vol 1 13 | 2645 | Vol 2 180 | 3613 | Vol 2 90 | 4540 | Vol 2 400 | 5191 | Vol 1 402 | 5767 | Vol 2 231 |
| 0260 | Vol 1 436 | 1560 | Vol 1 159 | 2012 | Vol 2 174 - 302 | 2647 | Vol 2 180 | 3700 | Vol 2 260 | 4625 | Vol 2 406 | 5192 | Vol 1 402 | 5770 | Vol 1 238 |
| 0270 | Vol 1 120 | 1570 | Vol 1 159 | 2013 | Vol 2 174 - 302 | 2800 | Vol 2 466 | 3702 | Vol 2 260 | 4630 | Vol 2 406 | 5410 | Vol 2 195 - 322 | 5772 | Vol 1 238 |
| 0275 | Vol 1 120 | 1575 | Vol 1 150 | 2014 | Vol 2 174 | 2805 | Vol 2 466 | 3704 | Vol 2 260 | 4635 | Vol 2 406 | 5412 | Vol 2 195 - 322 | 5774 | Vol 1 238 |
| 0299 | Vol 1 129 | 1580 | Vol 1 150 | 2110 | Vol 1 186 | 2810 | Vol 2 466 | 3706 | Vol 2 260 | 4640 | Vol 2 406 | 5425 | Vol 2 322 | 5776 | Vol 1 238 |
| 0300 | Vol 1 129 | 1585 | Vol 1 150 | 2111 | Vol 1 186 | 2815 | Vol 2 466 | 3710 | Vol 2 260 | 4660 | Vol 2 251 | 5427 | Vol 2 322 | 5778 | Vol 1 238 |
| 0301 | Vol 1 129 | 1590 | Vol 1 150 | 2112 | Vol 1 186 | 2820 | Vol 2 466 | 3714 | Vol 2 260 | 4662 | Vol 2 251 | 5430 | Vol 2 195 | 5780 | Vol 1 238 |
| 0302 | Vol 1 129 | 1650 | Vol 1 423 | 2113 | Vol 1 186 | 2825 | Vol 2 466 | 3716 | Vol 2 260 | 4665 | Vol 2 251 | 5432 | Vol 2 195 | 5905 | Vol 2 74 |
| 0303 | Vol 1 129 | 1655 | Vol 1 423 | 2120 | Vol 1 186 | 3225 | Vol 1 370 | 3718 | Vol 2 260 | 4670 | Vol 2 251 | 5435 | Vol 2 195 | 5910 | Vol 2 74 |
| 0309 | Vol 1 129 | 1660 | Vol 1 423 | 2121 | Vol 1 186 | 3230 | Vol 1 370 | 3720 | Vol 1 172 | 4675 | Vol 2 251 | 5437 | Vol 2 195 | 5915 | Vol 2 74 |
| 0310 | Vol 1 129 | 1670 | Vol 1 423 | 2122 | Vol 1 186 | 3235 | Vol 1 24 | 3724 | Vol 1 172 | 4680 | Vol 2 255 - 376 | 5470 | Vol 2 327 | 5920 | Vol 2 74 |
| 0311 | Vol 1 129 | 1675 | Vol 2 266 | 2141 | Vol 1 193 | 3300 | Vol 2 24 - 28 | 3726 | Vol 1 172 | 4684 | Vol 2 370 | 5471 | Vol 2 327 | 5922 | Vol 2 74 |
| 0312 | Vol 1 129 | 1680 | Vol 2 266 | 2142 | Vol 1 193 | 3303 | Vol 2 24 - 28 | 3728 | Vol 1 172 | 4688 | Vol 2 370 | 5472 | Vol 2 327 | 5924 | Vol 2 74 |
| 0315 | Vol 1 142 | 1685 | Vol 2 266 | 2143 | Vol 1 193 | 3306 | Vol 2 24 - 28 | 3730 | Vol 1 172 | 4695 | Vol 2 370 | 5474 | Vol 2 327 | 5926 | Vol 2 74 |
| 0320 | Vol 1 132 | 1686 | Vol 2 266 | 2155 | Vol 1 184 | 3310 | Vol 2 24 - 28 | 3734 | Vol 1 174 | 4697 | Vol 2 370 | 5476 | Vol 2 327 | 5930 | Vol 1 98 |
| 0325 | Vol 1 132 | 1690 | Vol 2 266 | 2165 | Vol 1 190 | 3313 | Vol 2 24 - 28 | 3736 | Vol 1 174 | 4700 | Vol 2 370 | 5480 | Vol 2 327 | 5935 | Vol 1 98 |
| 0330 | Vol 1 132 | 1692 | Vol 2 266 | 2167 | Vol 1 190 | 3316 | Vol 2 24 - 28 | 3760 | Vol 2 118 | 4702 | Vol 2 370 | 5481 | Vol 2 327 | 5940 | Vol 1 98 |
| 0338 | Vol 1 132 | 1694 | Vol 2 266 | 2260 | Vol 2 292 | 3320 | Vol 2 24 - 28 | 3764 | Vol 2 118 | 4710 | Vol 2 452 | 5485 | Vol 2 327 | 5945 | Vol 1 410 |
| 0347 | Vol 1 138 | 1720 | Vol 2 98 | 2262 | Vol 2 292 | 3323 | Vol 2 24 - 28 | 3900 | Vol 2 204 | 4715 | Vol 2 452 | 5486 | Vol 2 327 | 5950 | Vol 1 410 |
| 0348 | Vol 1 138 | 1722 | Vol 2 98 | 2263 | Vol 2 292 | 3326 | Vol 2 24 - 28 | 3905 | Vol 2 204 | 4720 | Vol 2 452 | 5487 | Vol 2 327 | 5955 | Vol 1 410 |
| 0361 | Vol 1 138 | 1725 | Vol 2 98 | 2270 | Vol 1 115 | 3330 | Vol 2 24 - 28 | 3910 | Vol 2 204 | 4780 | Vol 2 448 | 5491 | Vol 2 327 | 5957 | Vol 1 410 |
| 0374 | Vol 1 143 | 1727 | Vol 2 98 | 2272 | Vol 1 115 | 3333 | Vol 2 24 - 28 | 3915 | Vol 2 204 | 4785 | Vol 2 448 | 5495 | Vol 1 392 | 5965 | Vol 1 410 |
| 0375 | Vol 1 143 | 1728 | Vol 2 102 | 2277 | Vol 1 115 | 3336 | Vol 2 24 - 28 | 3920 | Vol 1 180 | 4800 | Vol 2 421 | 5496 | Vol 1 392 | 5970 | Vol 1 410 |
| 0376 | Vol 1 142 | 1729 | Vol 2 108 | 2282 | Vol 1 114 | 3350 | Vol 2 32 | 3925 | Vol 1 180 | 4801 | Vol 2 421 | 5497 | Vol 1 392 | 5972 | Vol 1 410 |
| 0377 | Vol 1 142 | 1730 | Vol 2 102 | 2288 | Vol 1 114 | 3353 | Vol 2 32 | 3930 | Vol 1 180 | 4802 | Vol 2 421 | 5500 | Vol 1 399 | 5975 | Vol 2 186 - 240 |
| 0378 | Vol 1 143 | 1732 | Vol 2 108 | 2292 | Vol 2 171 | 3360 | Vol 2 34 | 3935 | Vol 1 180 | 4803 | Vol 2 421 | 5505 | Vol 1 399 | 5977 | Vol 2 186 - 240 |
| 0700 | Vol 1 429 | 1735 | Vol 2 102 | 2298 | Vol 2 171 | 3363 | Vol 2 34 | 4057 | Vol 2 428 | 4804 | Vol 2 420 | 5510 | Vol 1 399 | 5979 | Vol 2 186 - 240 |
| 0712 | Vol 1 429 | 1737 | Vol 2 108 | 2330 | Vol 1 222 | 3500 | Vol 2 80 | 4062 | Vol 2 428 | 4805 | Vol 2 420 | 5515 | Vol 1 399 | 5981 | Vol 2 187 - 240 |
| 0720 | Vol 2 311 | 1740 | Vol 2 102 | 2331 | Vol 1 222 | 3503 | Vol 2 80 | 4067 | Vol 2 428 | 4810 | Vol 2 420 | 5520 | Vol 1 198 | 5983 | Vol 2 187 - 240 |
| 0721 | Vol 2 311 | 1742 | Vol 2 108 | 2332 | Vol 1 222 | 3505 | Vol 2 80 | 4072 | Vol 1 232 - Vol 2 428 | 4811 | Vol 2 420 | 5525 | Vol 1 198 | 5985 | Vol 2 187 - 240 |
| 0820 | Vol 1 204 | 1745 | Vol 2 102 | 2333 | Vol 1 222 | 3508 | Vol 2 80 | 4077 | Vol 1 232 - Vol 2 428 | 4812 | Vol 2 420 | 5580 | Vol 1 362 | 5987 | Vol 2 241 |

| Model | Vol | Page | Model | Vol | Page | Model | Vol | Page | Model | Vol | Page |
|-------|-------|-----------------|-------|-------|-----------------|-------|-------|---------------|-------|-------|------|
| 5989 | Vol 2 | 241 | 6474 | Vol 1 | 88 | 7310 | Vol 1 | 72 | A361 | Vol 1 | 50 |
| 5991 | Vol 2 | 241 | 6476 | Vol 1 | 88 | 7313 | Vol 1 | 72 | A362 | Vol 1 | 50 |
| 5993 | Vol 2 | 241 | 6500 | Vol 1 | 259 - Vol 2 143 | 7316 | Vol 1 | 72 | A363 | Vol 1 | 50 |
| 5995 | Vol 2 | 241 | 6504 | Vol 1 | 259 - Vol 2 143 | 7320 | Vol 1 | 73 | A364 | Vol 1 | 50 |
| 6006 | Vol 1 | 433 | 6510 | Vol 1 | 259 - Vol 2 143 | 7323 | Vol 1 | 73 | A365 | Vol 1 | 50 |
| 6007 | Vol 1 | 433 | 6514 | Vol 1 | 259 - Vol 2 143 | 7326 | Vol 1 | 73 | A366 | Vol 1 | 50 |
| 6011 | Vol 1 | 433 | 6520 | Vol 1 | 259 - Vol 2 143 | 7338 | Vol 1 | 387 | A367 | Vol 1 | 50 |
| 6012 | Vol 1 | 433 | 6524 | Vol 1 | 259 - Vol 2 143 | 7339 | Vol 1 | 387 | A368 | Vol 1 | 50 |
| 6040 | Vol 2 | 306 | 6525 | Vol 1 | 259 - Vol 2 143 | 7348 | Vol 1 | 387 | A369 | Vol 1 | 50 |
| 6041 | Vol 2 | 306 | 6528 | Vol 1 | 259 - Vol 2 143 | 7350 | Vol 1 | 73 | A370 | Vol 1 | 50 |
| 6045 | Vol 2 | 306 | 6529 | Vol 1 | 259 - Vol 2 143 | 7353 | Vol 1 | 73 | A371 | Vol 1 | 50 |
| 6046 | Vol 2 | 306 | 6530 | Vol 1 | 259 - Vol 2 143 | 7356 | Vol 1 | 73 | A372 | Vol 1 | 50 |
| 6095 | Vol 2 | 200 | 6534 | Vol 1 | 259 - Vol 2 143 | 7360 | Vol 1 | 78 | A373 | Vol 1 | 50 |
| 6100 | Vol 2 | 200 | 6538 | Vol 1 | 259 - Vol 2 143 | 7361 | Vol 1 | 78 | A374 | Vol 1 | 50 |
| 6105 | Vol 2 | 200 | 6540 | Vol 1 | 258 - Vol 2 145 | 7363 | Vol 1 | 78 | A375 | Vol 1 | 50 |
| 6160 | Vol 1 | 104 | 6542 | Vol 1 | 258 - Vol 2 145 | 7364 | Vol 1 | 78 | A376 | Vol 1 | 50 |
| 6165 | Vol 1 | 104 | 6560 | Vol 1 | 263 - Vol 2 147 | 7365 | Vol 1 | 78 | A377 | Vol 1 | 50 |
| 6200 | Vol 1 | 346 | 6561 | Vol 1 | 263 - Vol 2 147 | 7366 | Vol 1 | 78 | A378 | Vol 1 | 50 |
| 6205 | Vol 1 | 346 | 6570 | Vol 1 | 263 - Vol 2 147 | 7368 | Vol 1 | 78 | A379 | Vol 1 | 50 |
| 6210 | Vol 1 | 346 | 6571 | Vol 1 | 263 - Vol 2 147 | 7369 | Vol 1 | 78 | A380 | Vol 1 | 50 |
| 6215 | Vol 1 | 346 | 6575 | Vol 1 | 262 - Vol 2 146 | 7375 | Vol 1 | 387 | A381 | Vol 1 | 50 |
| 6220 | Vol 1 | 346 | 6576 | Vol 1 | 262 - Vol 2 146 | 7376 | Vol 1 | 387 | A382 | Vol 1 | 50 |
| 6225 | Vol 1 | 346 | 6580 | Vol 1 | 263 - Vol 2 147 | 7378 | Vol 1 | 387 | A383 | Vol 1 | 50 |
| 6230 | Vol 1 | 346 | 6581 | Vol 1 | 263 - Vol 2 147 | 7379 | Vol 1 | 387 | A384 | Vol 1 | 50 |
| 6235 | Vol 1 | 346 | 6583 | Vol 1 | 263 - Vol 2 147 | 7400 | Vol 1 | 458 | A385 | Vol 1 | 50 |
| 6240 | Vol 1 | 346 | 6584 | Vol 1 | 263 - Vol 2 147 | 7402 | Vol 1 | 458 | A386 | Vol 1 | 50 |
| 6245 | Vol 1 | 346 | 6586 | Vol 1 | 263 - Vol 2 147 | 7404 | Vol 1 | 458 | A387 | Vol 1 | 50 |
| 6250 | Vol 1 | 347 | 6587 | Vol 1 | 263 - Vol 2 147 | 7415 | Vol 2 | 298 | A388 | Vol 1 | 50 |
| 6255 | Vol 1 | 347 | 6590 | Vol 1 | 262 - Vol 2 146 | 7450 | Vol 1 | 31 | A389 | Vol 1 | 50 |
| 6260 | Vol 1 | 347 | 6591 | Vol 1 | 262 - Vol 2 146 | 7455 | Vol 1 | 31 | A390 | Vol 1 | 50 |
| 6265 | Vol 1 | 347 | 6600 | Vol 2 | 152 | 7460 | Vol 1 | 31 | A391 | Vol 1 | 50 |
| 6270 | Vol 1 | 347 | 6604 | Vol 2 | 152 | 7470 | Vol 1 | 31 | A392 | Vol 1 | 50 |
| 6275 | Vol 1 | 347 | 6610 | Vol 2 | 156 | 7475 | Vol 1 | 31 | A393 | Vol 1 | 50 |
| 6280 | Vol 1 | 347 | 6614 | Vol 2 | 156 | 7480 | Vol 1 | 382 | A414 | Vol 2 | 140 |
| 6285 | Vol 1 | 347 | 6620 | Vol 2 | 160 | 7485 | Vol 1 | 382 | A415 | Vol 2 | 140 |
| 6330 | Vol 2 | 126 - 224 | 6624 | Vol 2 | 160 | 7487 | Vol 1 | 382 | A416 | Vol 2 | 140 |
| 6331 | Vol 2 | 126 - 224 | 6630 | Vol 2 | 156 | 7490 | Vol 1 | 382 | A417 | Vol 1 | 260 |
| 6332 | Vol 2 | 126 - 224 | 6634 | Vol 2 | 156 | 7492 | Vol 1 | 382 | A418 | Vol 1 | 260 |
| 6333 | Vol 2 | 126 - 224 | 6640 | Vol 2 | 160 | 7494 | Vol 1 | 382 | A419 | Vol 1 | 260 |
| 6335 | Vol 2 | 126 - 224 | 6644 | Vol 2 | 160 | 7749 | Vol 2 | 276 | A420 | Vol 1 | 260 |
| 6340 | Vol 2 | 126 - 224 | 6650 | Vol 2 | 152 | 7750 | Vol 2 | 276 | A421 | Vol 1 | 260 |
| 6341 | Vol 1 | 480 | 6654 | Vol 2 | 152 | 7751 | Vol 2 | 276 | A422 | Vol 1 | 260 |
| 6343 | Vol 1 | 480 | 6658 | Vol 2 | 152 | 7752 | Vol 2 | 276 | A423 | Vol 1 | 260 |
| 6346 | Vol 1 | 480 | 6660 | Vol 2 | 156 | 7753 | Vol 2 | 276 | A424 | Vol 1 | 260 |
| 6348 | Vol 1 | 480 | 6664 | Vol 2 | 156 | 7940 | Vol 2 | 318 | A425 | Vol 1 | 260 |
| 6361 | Vol 1 | 480 - Vol 2 224 | 6668 | Vol 2 | 156 | 7942 | Vol 2 | 318 | A439 | Vol 1 | 362 |
| 6363 | Vol 1 | 480 - Vol 2 224 | 6670 | Vol 2 | 160 | A146 | Vol 1 | 54 - Vol 2 60 | A440 | Vol 1 | 362 |
| 6365 | Vol 1 | 480 - Vol 2 224 | 6674 | Vol 2 | 160 | A147 | Vol 1 | 54 - Vol 2 60 | A491 | Vol 2 | 140 |
| 6370 | Vol 1 | 480 - Vol 2 224 | 6678 | Vol 2 | 160 | A352 | Vol 1 | 50 - Vol 2 56 | A492 | Vol 2 | 140 |
| 6414 | Vol 2 | 287 | 6680 | Vol 2 | 156 | A353 | Vol 1 | 50 - Vol 2 56 | A493 | Vol 2 | 140 |
| 6416 | Vol 2 | 287 | 6684 | Vol 2 | 156 | A354 | Vol 1 | 50 - Vol 2 56 | Match | Vol 1 | 168 |
| 6418 | Vol 2 | 287 | 6688 | Vol 2 | 156 | A355 | Vol 1 | 50 - Vol 2 56 | | | |
| 6434 | Vol 1 | 84 | 6690 | Vol 2 | 160 | A356 | Vol 1 | 50 - Vol 2 56 | | | |
| 6436 | Vol 1 | 84 | 6694 | Vol 2 | 160 | A357 | Vol 1 | 50 - Vol 2 56 | | | |
| 6438 | Vol 1 | 84 | 6698 | Vol 2 | 160 | A358 | Vol 1 | 50 | | | |
| 6444 | Vol 2 | 283 | 6700 | Vol 2 | 166 | A359 | Vol 1 | 50 | | | |
| 6446 | Vol 2 | 283 | 6702 | Vol 2 | 166 | A360 | Vol 1 | 50 | | | |

CO Arquitectura and Altointeriorismo
(Page 8, 44, 58)

Photography: Alejandra Urquiza
(Page 9, 145)

Photography: Matej Hakár
(Page 10)

Architecture: César Béjar
(Page 10)

Photography: Fernando Guerra
(Page 17)

Fieldwork Design
Photography: Jeremy Bittermann / JBSA
(Page 22)

CO Arquitectura and Altointeriorismo
(Page 44, 58)

Photography: Alex Bagué
(Page 47)

@ceramicasantagostino
(Page 48)

Photography: @fotografadearquitectura
Architecture: R21 Arkitekter
@r21arkitekter / Constructor Saulius Balsevicius
@gravitas_bygg_as
(Pg 49)

Photography: Raúl Candales
Project: VIVE ESTUDIO
(Page 58)

Architect: Marià Castelló
(Page 58, 243)

Architecture: b720 Fermín Vázquez
(Page 59)

Architecture: Marià Castelló
@mcastello_arch
(Page 67)

Architecture: © Fran Silvestre Arquitectos
(Page 69)

Architecture firm: DOST
Photography: Andrin Winteler
(Page 69)

Architecture: Inmaculada González,
Harald Schönegger
Photography: Fernando Alda
(Page 70)

Photography: © Pedro Vennucchi
Architecture: David Ito
(Page 91)

Photography: Sandra Rojo
Architecture: Zoga Arquitectura
(Page 93)

Photography: Ricardo Gonçalves
www.ricardogoncalves.pt
Architecture: Aboim Inglez Arquitectos
(Page 108)

Photography: Ricardo Gonçalves
Architecture: Aboim Inglez Arquitectos
(Page 121)

Project: Leman Locke Hotel
Grzywinski+Pons
(Page 128)

Nacho Carbó
Photography: Mariela Apollonio
(Page 137, 369)

Photography: Germán Saíz
Architecture: Estudio Reciente
(Page 147)

VMS Investment Group Headquarters
Aedas Interiors
(Page 162, 165)

Photography: Frank Schinski,
Ostkreuz
www.frankschinski.de
(Page 172)

VSHD Design
Architect: Rania M Hamed
(Page 175)

Showroom: WSA Showroom
(Page 175)

Photography: Andrew Begley
Architecture: EGO Group Interiors:
Davenport Campbell Electrical:
Medland Metropolis
(Page 175)

Showroom: WSA Showroom
(Page 182)

VSHD Design
Architect: Rania M Hamed
(Page 187)

Project: Penthouse / Apartment in Tel Aviv
Photography: Amit Geron
Architecture: Pitsou Kedem Architects
Lighting Design: Orly Avron Alkabes
(Pag 192)

Interior and object consulting:
Christin Kaldma
www.christinkaldma.de
(Page 212)

Photography: Ewout Huibers
Architecture: SevilPeach Architecture + Design
Client: Spaces
(Page 215, 219, 222)

Photography: Adrià Goula
Architect: Gabriel Montañés
(Page 229, 244)

Photography: João Carmo Simões
www.joaocarmosimoes.com
(Page 229)

Photography: @fotografadearquitectura
Architecture: Ramón Esteve Estudio
(Page 244)

Photography: José Losada
@joselosadaphotography
(Page 247)

Studio M
(Page 249)

Photography: Highlite Images
Architecture: YUAN Architects
(Page 257)

Project: Desalto store
(Page 265)

Architect: Cristina Soler from Arquemo
Photography: Enric Badrinas
(Page 269)

Photography: Fernando Alda
Architecture: Inmaculada González,
Harald Schönegger
Project: Private house in Seville.
(Page 290, 313)

Barozzi Veiga
Photography: Mariela Apollonio
(Page 296)

Photography: Filippo Poli
(Page 298)

Photography: Dieter Muenchen
(Page 321)

Architecture: BAAS arquitectura
(Page 322)

Photography: Emily Gilbert
(Page 336)

Architecture: Carles Enrich
Photography: Adrià Goula
(Page 337)

Photography & Architecture:
Simón García
(Page 339)

Bernadí Hub
www.bernadi.es
(Page 356, 359, 360)

DTI Group - Office
Architecture: VEVS Amsterdam
(Rob van Sprang - Martijn d'Herripon)
Photography: Mike Bink
(Pg 409)

Zentrum la Garriga
(Pg 426)

Vibia Lighting, S.L.U.

Spain & Portugal T. +34 934 796 970

International T. +34 934 796 971

hello@vibia.com

www.vibia.com

Atmosphere Design

A space is an ecosystem; a combination of different elements that come together to create an atmosphere. With the right tools, a designer can shape the atmosphere of a space.

What determines our sense of wellbeing is the type of space and how individuals use it; the visual hierarchy and harmony created by the composition and combination of material and spatial elements; and the fusion of different lighting effects as they accompany us throughout the day.

1

PENDANT
PLUSMINUS
FLOOR & TABLE

2

CEILING
WALL
OUTDOOR



VIBIA

A New Approach to Atmosphere Design

A space is an ecosystem; a combination of different elements that come together to create an atmosphere. With the right tools, a designer can shape the atmosphere of a space.



What determines our sense of wellbeing is the type of space and how individuals use it; the visual hierarchy and harmony created by the composition and combination of material and spatial elements; and the fusion of different lighting effects as they accompany us throughout the day.

Designing the perfect atmosphere requires the consideration of **scene composition** and **control system integration** from the beginning of a project.



Lighting Project Design with Scenes

Design by Use & Emotions

Visual Hierarchy

Density of Light

Design by Use & Emotions

Relaxation



Activation



Concentration



Socialisation

Designing by use and emotions involves exploring how individuals might use a space and designing **adaptable scenes** to suit their needs, considering how people might like to feel at **certain times of day** and how the atmosphere of the space might enhance these emotions.

Visual Hierarchy



Considering the key elements of the interior and create visual hierarchy using light to **direct the gaze** and highlight certain aspects of the space. **Light** and **material** elements come together to generate depth and harmony.

Density of Light



The key is to find a balance between soft and more accentuated light through a **unique blend of lighting effects** (direct, indirect and diffuse) and subtle variations in **intensity, tone** and **colour gradient**.

Control System Design

Designing the perfect atmosphere requires designing the control system right from the start of each project.

This facilitates the creation of hybrid scenes that **enhance wellbeing** while **reducing energy consumption and project costs**.

Control System Integration



Our portfolio of products and digital tools are designed to seamlessly integrate with any control systems and Building Management Systems (BMS).

Vibia Product Control Options

Analog (On/Off, Push, Sensor, TRIAC, 1-10V, 0-10V)
Digital (DALI 2, Lutron)
Smart (Casambi, ProtoPixel)

Integration with

Control System (Wired, Wireless)
Building Management Systems (BMS)
Used in large buildings to ensure centralised control and energy savings.

End User Interaction Design

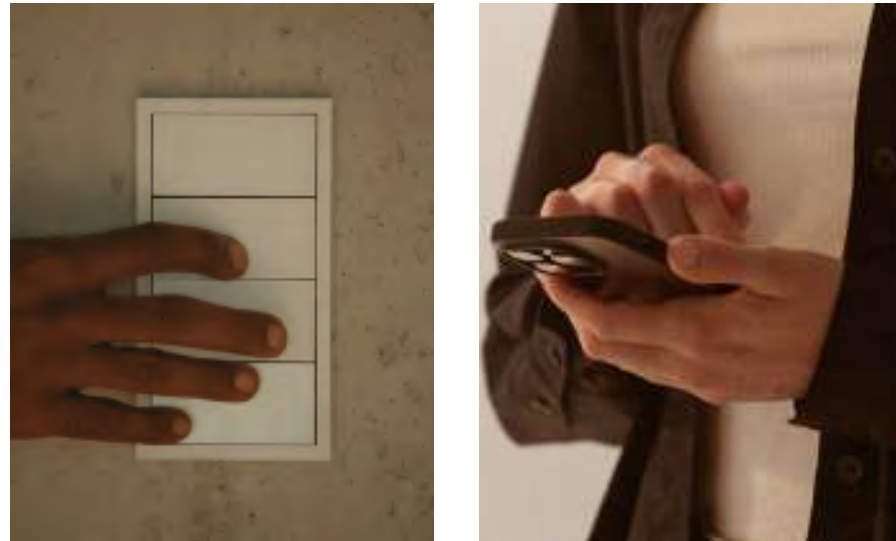

Incorporating end user interaction and automation from the beginning of every lighting project is essential. This ensures that the design is intuitive and responsive to user needs, enhancing the overall experience.

User Interfaces

Switches, apps, and voice assistants for simplified light interaction.

Automation

Use of time control. Smart sensors trigger lighting adjustments automatically.

Scenes & Control System Design Support

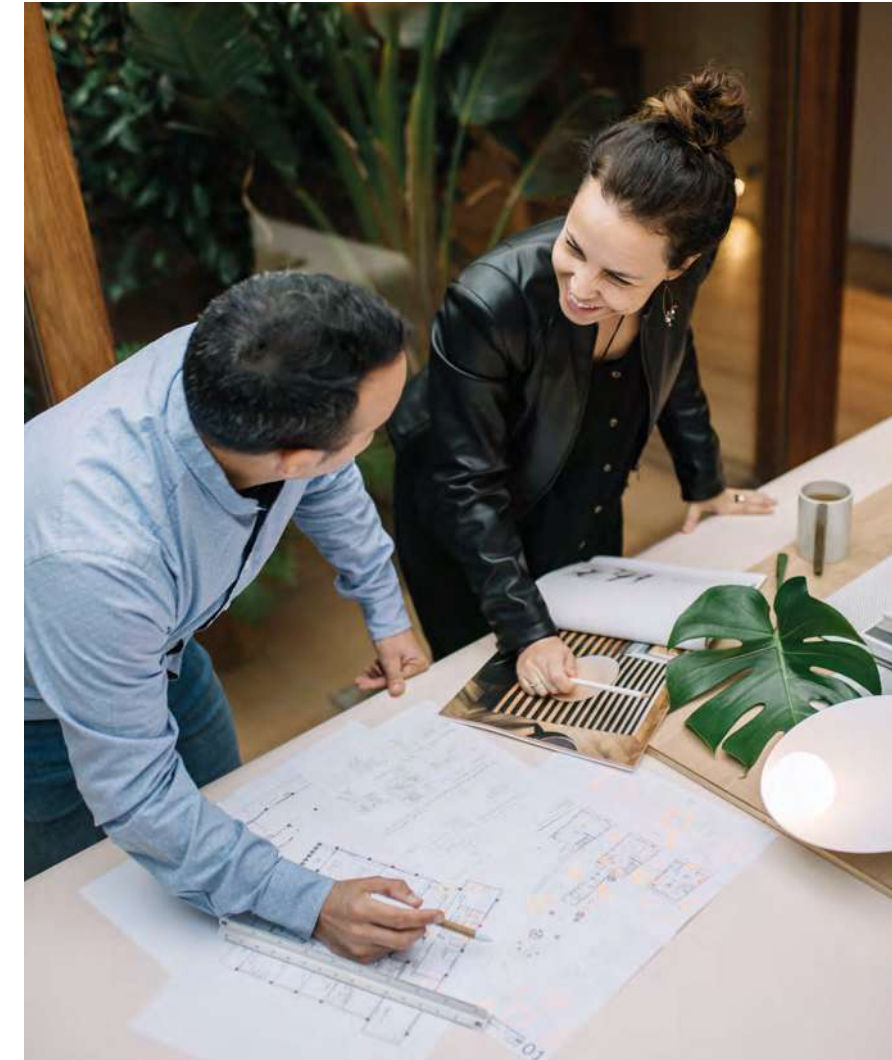

We offer personalised support with **control system approach**, as well as assistance and recommendation when designing an atmosphere of wellbeing.

By Your Side

From Project Support to Usage.

Creating scenes of wellbeing requires guidance and support throughout the entire project journey (end-to-end). From **design** and composition through to **installation** and **end-user interaction**, Vibia's team is prepared to help you with any technical or commercial need you might have.



Volume

1

| | |
|---------------------|-----|
| Pendant | 1 |
| Plusminus | 271 |
| Floor & Table | 355 |
| Lighting Typologies | 486 |
| Support Portfolio | 490 |
| Item index | 492 |
| Acknowledgements | 495 |

Volume

2

| | |
|---------------------|-----|
| Ceiling | 1 |
| Wall | 209 |
| Outdoor | 359 |
| Lighting Typologies | 472 |
| Support Portfolio | 476 |
| Item index | 478 |
| Acknowledgements | 481 |

Collections

Africa

Floor & Table
Vol1 356

Algorithm Free

Pendant
Vol1 200

Algorithm Grid

Pendant
Vol1 206

Alpha

Wall
Vol2 316

Array

Pendant
Vol1 2

Balance

Floor & Table
Vol1 400

Bamboo

Outdoor
Vol2 414

Bigger

Pendant
Vol1 176
Ceiling
Vol2 202

Bind

Pendant
Vol1 240
Ceiling
Vol2 128

Bind Solo

Ceiling
Vol2 148

Break

Outdoor
Vol2 430

Break Plus

Outdoor
Vol2 435

Brisa

Outdoor
Vol2 402

Circle

Ceiling
Vol2 18

Circus

Pendant
Vol1 32
Ceiling
Vol2 42

Circus Solo

Pendant
Vol1 56
Ceiling
Vol2 62

Class

Outdoor
Vol2 456

Cosmos

Pendant
Vol1 160

Dama

Pendant
Vol1 20
Floor & Table
Vol1 364

Dots

Wall
Vol2 242

Dots Glass

Wall
Vol2 252
Outdoor
Vol2 372

Dots Outdoor

Outdoor
Vol2 360

Duo

Ceiling
Vol2 2

Duo Petra

Ceiling
Vol2 12

Empty

Outdoor
Vol2 408

Flamingo

Pendant
Vol1 154

Flamingo Mini

Pendant
Vol1 144

Flat

Pendant
Vol1 94
Floor & Table
Vol1 405
Ceiling
Vol2 68

Funnel

Ceiling
Vol2 172
Wall
Vol2 300

Ghost

Pendant
Vol1 90
Floor & Table
Vol1 438

Guise

Pendant
Vol1 110
Ceiling
Vol2 168
Wall
Vol2 288

Halo

Pendant
Vol1 218
Wall
Vol2 336

Halo Jewel

Pendant
Vol1 224

I.Cono

Floor & Table
Vol1 424
Wall
Vol2 308

Jazz

Floor & Table
Vol1 444

June

Outdoor
Vol2 446

Knit

Pendant
Vol1 26
Floor & Table
Vol1 378

Kontorno

Pendant
Vol1 80
Wall
Vol2 278

Lily

Pendant
Vol1 14
Floor & Table
Vol1 372

Line

Ceiling
Vol2 76

Match

Pendant
Vol1 166

Collections

Mayfair

Pendant
Vol1 194
Floor & Table
Vol1 394

Mayfair Mini

Floor & Table
Vol1 388

Meridiano

Outdoor
Vol2 450

Musa

Floor & Table
Vol1 454
Wall
Vol2 296

North

Pendant
Vol1 264
Floor & Table
Vol1 412
Wall
Vol2 330

Offset

Floor & Table
Vol1 460
Ceiling
Vol2 94
Wall
Vol2 348

Origami

Wall
Vol2 312
Outdoor
Vol2 388

Out

Floor & Table
Vol1 468
Outdoor
Vol2 378

Palma

Pendant
Vol1 170
Ceiling
Vol2 116
Wall
Vol2 256

Palo Alto

Outdoor
Vol2 394

Pin

Floor & Table
Vol1 418
Wall
Vol2 262

Plusminus

Plusminus
Vol1 271

Plusminus Solo

Floor & Table
Vol1 472
Ceiling
Vol2 120
Wall
Vol2 216

Puck

Ceiling
Vol2 192
Wall
Vol2 320

Puck Wall Art

Wall
Vol2 324

Rhythm Horizontal

Pendant
Vol1 182

Rhythm Vertical

Pendant
Vol1 188

Set

Wall
Vol2 274

Skán

Pendant
Vol1 116
Floor & Table
Vol1 434

Slim

Pendant
Vol1 212

Spa

Ceiling
Vol2 182
Wall
Vol2 232

Sticks

Pendant
Vol1 66
Wall
Vol2 340

Sticks Solo

Pendant
Vol1 384
Floor & Table
Vol1 384

Structural

Ceiling
Vol2 176
Wall
Vol2 268

Suite

Floor & Table
Vol1 430
Wall
Vol2 304

Tempo

Pendant
Vol1 234
Wall
Vol2 226

Top

Ceiling
Vol2 36
Wall
Vol2 210

Tube

Pendant
Vol1 106

Tube Free

Pendant
Vol1 100
Ceiling
Vol2 196

Up

Ceiling
Vol2 188

Warm

Pendant
Vol1 122
Floor & Table
Vol1 448

Wind

Pendant
Vol1 230
Outdoor
Vol2 422

Wireflow

Pendant
Vol1 126

Wireflow Chandelier

Pendant
Vol1 140

Wireflow Free

Pendant
Vol1 134

Wireflow Lineal

Pendant
Vol1 130

Ceiling

Ceiling

| | | |
|----------------------|--------------------------|---------------------|
| Bigger 202 | Flat 68 | Puck 192 |
| Bind 128 | Funnel 172 | Spa 182 |
| Bind Solo 148 | Guise 168 | Structural 176 |
| Circle 18 | Line 76 | Top 36 |
| Circus 42 | Offset 94 | Tube Free 196 |
| Circus Solo 62 | Palma 116 | Up 188 |
| Duo 2 | Plusminus Solo 120 | |
| Duo Petra 12 | | |

Duo



Design by Ramos & Bassols.

Duo brings natural warmth to a space. Its gently curved form encases a supple wood-finished interior, lending a soothing sensibility.





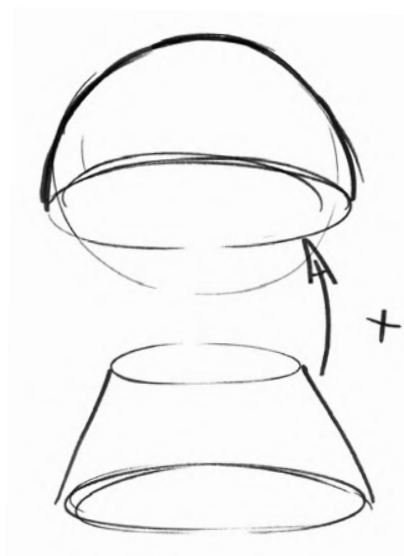

Articulated through simple volumes with a sculptural quality, Duo becomes a focal point without the need for suspension. Crafted in veined oak and matte-lacquered aluminum, its sleek shell and richly textured veneer yield an intriguing material contrast, complemented by a rich, diffuse downlight.





Vibia's general lighting, spot accent and downlight luminaires include the option of tunable white. Combining these zenithal tunable white lights with the rest of the diffused and indirect lighting effects of Vibia's portfolio, you can design the perfect scene for every moment and use.



Tunable White (2200K - 4000K)
Tunable white lighting option allows for comprehensive temperature regulation depending on the atmosphere of every scene.

Static White 2700K; 3500K
You can select the static white option that fits best with the desired ambience.

Contact Vibia Support Service at vibia.com for any kind of assistance or recommendation when designing an atmosphere of wellbeing, or if you require support with control system approach.

“We chose wood because it’s a natural and quality material. It lends warmth and at the same time contrasts with the surrounding meta”

Ramos & Bassols.



4870

Ø 47,5 cm



4872

Ø 78,5 cm



4878

Ø 70 cm



4880

Ø 70 cm



4874

Ø 35 cm



4876

Ø 35 cm



- 18 Graphite (ADAPTA RF9913WX)
- 58 Cream (RAL 7044)
- 93 White (RAL 9016)

Finish customization
(Available options: Vibia colour palette)

Diffuser: PC- Polycarbonate
Main Body: Aluminum
Inner structure: Oak wood

LED Colour Temperature
Static White
2700 K; 3500 K
Tunable White (2200 K - 4000 K)
CRI>90

Control
Analog: Push; 1-10V
Digital: DALI-2; DALI-2 DT8
Smart: Casambi

Duo Petra



Design by Ramos & Bassols.

Duo Petra's slate veneer lends a timeless elegance to the collection. The ceiling lamp's gently curved form encases a velvety slate-finished interior for a sophisticated, natural aesthetic.





Simple volumes meet sculptural quality in Duo Petra, expressly designed for those lower-ceiling rooms where a pendant fitting is not suitable. It stands harmonious and sleek, its satinised diffuser radiating with a soft and general diffuse light.



Vibia's general lighting, spot accent and downlight luminaires include the option of tunable white. Combining these zenithal tunable white lights with the rest of the diffused and indirect lighting effects of Vibia's portfolio, you can design the perfect scene for every moment and use.



Tunable White (2200K - 4000K)
Tunable white lighting option allows for comprehensive temperature regulation depending on the atmosphere of every scene.

Static White 2700K; 3500K
You can select the static white option that fits best with the desired ambience.

Contact Vibia Support Service at vibia.com for any kind of assistance or recommendation when designing an atmosphere of wellbeing, or if you require support with control system approach.

Duo Petra's silky slate-lined interior provides a subtle contrast with its matte aluminum outer shell, a sober and modern aesthetic for an elegant interior style.



4871

Ø 47,5 cm



4873

Ø 78,5 cm



- 18 Graphite (ADAPTA RF9913WX)
- 58 Cream (RAL 7044)
- 93 White (RAL 9016)

Finish customization
(Available options: Vibia colour palette)

Diffuser: PC- Polycarbonate
Main Body: Aluminum
Inner structure: Slate

LED Colour Temperature
Static White
2700 K; 3500 K
Tunable White (2200 K - 4000 K)
CRI>90

Control
Analog: Push; 1-10V
Digital: DALI-2; DALI-2 DT8
Smart: Casambi

4875

Ø 35 cm



4877

Ø 35 cm



4879

Ø 70 cm



4881

Ø 70 cm



Circle

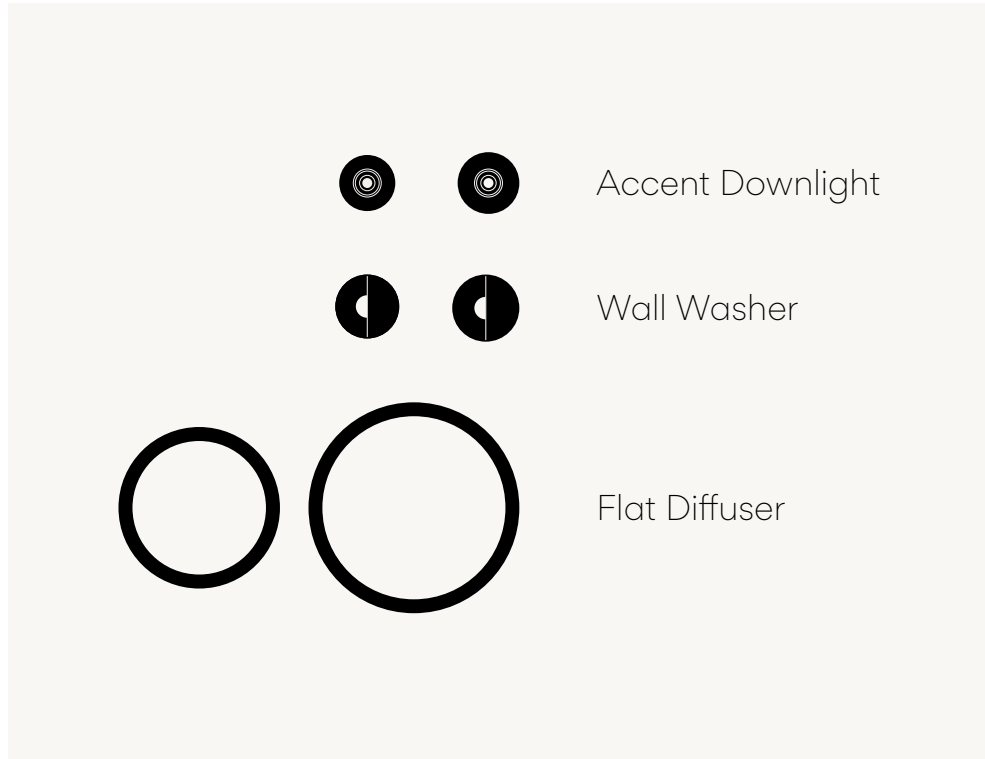

Combining accent, diffuse and general lighting effects with dynamic control and temperature regulation, Circle is a highly-functional complementary product designed to curate a nuanced ambience.

Dynamic light

Dynamic light allows professionals to play with subtle degrees of intensity and colour temperature to recreate a subtle ambience for every scene within a lighting project

Designing an atmosphere of wellbeing is based on two main axes: **space** and **time**. The axis of time implies the concept of dynamic light.

Atmosphere design is intentional, depending on the **design of different scenes according to the specific use of a space** as it evolves throughout the day. Light is dynamic because ambience also depends **on the time of day** and on the influence of the natural light at every moment.



Throughout the day our circadian rhythms respond primarily to light, which regulates our sense of physical and mental wellbeing

Comfortable environments

Vibia's spot accent, downlight and general lighting luminaires include the option of tunable white. Combining these zenithal tunable white lights with the rest of the diffused and indirect lighting effects of Vibia's portfolio, you can design the perfect scene for every moment and use.

Tunable lighting allows for comprehensive temperature regulation and intensity: colour temperature can be precisely tuned depending on the desired atmosphere for every scene.

Static White

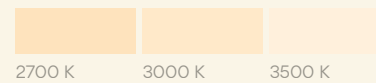

Tunable White

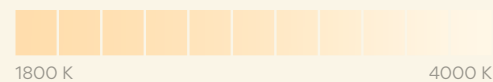

Dim-To-Warm

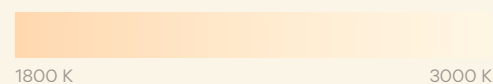

Contact Vibia Support Service at vibia.com for any kind of assistance or recommendation when designing an atmosphere of wellbeing, or if you require support with control system approach.



Scenographic lighting plays a critical role in retail design. Light enhances the expressive capacity of a space, creating visual hierarchy and ensuring a dialogue with customers. Different effects can be used to highlight certain products, draw the eye to particular areas and determine the general atmosphere, strengthening the shopping experience. Diffusers and wall-washers ensure comfortable background lighting, while accent downlights and spots create brilliance and contrast, lifting products out of their setting for dramatic effect.



Accent Downlight - Colour

COLOUR MODELS

A set of minimalist accent downlights in four versatile finishes attracts a relaxed gaze to a specific point of light. The option of a trimless profile offers seamless integration within the surrounding architecture.

- 11 Black (NCS S 8500-N)
- 23 Warm White (NCS S 0502-Y50R)
- 24 Beige M1 (NCS S 2005-Y50R)
- 37 Terra Red (NCS S 4040-Y70R)

Body: Aluminum
Shade: PC- Polycarbonate
Lens: PMMA

LED Colour Temperature

Ø 6 cm; Ø 7 cm

Static White
2700 K - 607 lm
3000 K - 634 lm
3500 K - 657 lm
6,2W

Dim-To-Warm (1800 K - 3000 K)
611 lm 5,8W

Tunable White (1800 K - 4000 K)
308 lm - 504 lm 5,5W

Ø 10 cm; Ø 11 cm

Static White
2700 K - 1256 lm
3000 K - 1313 lm
3500 K - 1360 lm
12,4W

Dim-To-Warm (1800 K - 3000 K)
1258 lm 11,6W

Tunable White (1800 K - 4000 K)
571 lm - 895 lm 8,9W

CRI>90

Control

Analog: On/Off; Push; 1-10V
Digital: DALI-2; DALI-2 DT8
Smart: Casambi

Electrical connection

Built-in (Driver included)
Remote

Visit vibia.com to group several pieces with just one electrical point

Updated detailed spec sheets on vibia.com



↑ IP20
↓ IP40





Accent Downlight - Wood

WOOD MODELS

The collection includes the option of a natural wood in White oak or Walnut. Reflected in its textured surface, warm light bathes the space, producing a rich and restorative atmosphere.

- 82 White oak
- 83 Walnut

Body: Aluminum
Shade: Wood
Lens: PMMA

LED Colour Temperature

Ø 6 cm; Ø 7 cm

Static White
2700 K - 607 lm
3000 K - 634 lm
3500 K - 657 lm
6,2W

Dim-To-Warm (1800 K - 3000 K)
611 lm 5,8W

Tunable White (1800 K - 4000 K)
308 lm - 504 lm 5,5W

Ø 10 cm; Ø 11 cm

Static White
2700 K - 1256 lm
3000 K - 1313 lm
3500 K - 1360 lm
12,4W

Dim-To-Warm (1800 K - 3000 K)
1258 lm 11,6W

Tunable White (1800 K - 4000 K)
571 lm - 895 lm 8,9W

CRI>90

Control

Analog: On/Off; Push; 1-10V
Digital: DALI-2; DALI-2 DT8
Smart: Casambi

Electrical connection

Built-in (Driver included)
Remote

Visit vibia.com to group several pieces with just one electrical point

Updated detailed spec sheets on vibia.com



TRIM



TRIMLESS

3300 Narrow
3303 Medium
3306 Wide

Ø 7 cm



3310 Narrow
3313 Medium
3316 Wide

Ø 6 cm

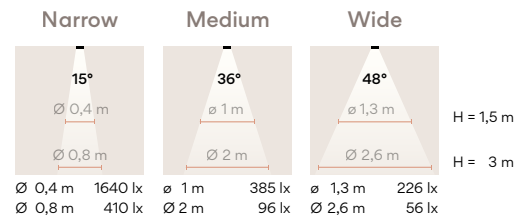

3320 Narrow
3323 Medium
3326 Wide

Ø 11 cm



3330 Narrow
3333 Medium
3336 Wide

Ø 10 cm

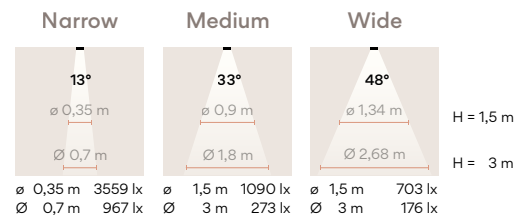

Circle is designed to complement Vibia's wider product range. Its four contemporary tones and trim or trimless profile adapt to both high contrast and subtle design requirements. Especially suited to a natural, rounded aesthetic, the walnut and oak finishes combine well with Dots and Duo.



Wall Washer

A Wall Washer option can be used to illuminate a vertical surface with uniform brightness, to accentuate an entrance or to highlight a specific feature such as a shelving unit. Light reflected from the matte surface of the wall makes the space appear brighter and provides soft, diffuse illumination.

- 11 Black (NCS S 8500-N)
- 23 Warm White (NCS S 0502-Y50R)
- 24 Beige M1 (NCS S 2005-Y50R)
- 37 Terra Red (NCS S 4040-Y70R)

Body: Aluminum
Shade: PC- Polycarbonate
Lens: PMMA

LED Colour Temperature

Static White
2700 K - 914 lm
3000 K - 956 lm
3500 K - 990 lm
7,4W

Dim-To-Warm (1800 K - 3000 K)
1258 lm 11,6W

Tunable White (1800 K - 4000 K)
571 lm - 895 lm 8,9W

CRI>90

Control

Analog: On/ Off; Push; 1-10V
Digital: DALI-2; DALI-2 DT8
Smart: Casambi

Electrical connection

Built-in (Driver included)
Remote

Visit vibia.com to group several pieces with just one electrical point

Updated detailed spec sheets
on vibia.com



Flat Diffuser

Featuring a translucent cover to control the brightness, the Flat Diffuser model provides soft, general lighting for a comfortable atmosphere or effective transitioning between different spaces.

- 11 Black (NCS S 8500-N)
- 23 Warm White (NCS S 0502-Y50R)
- 24 Beige M1 (NCS S 2005-Y50R)
- 37 Terra Red (NCS S 4040-Y70R)

Body: Aluminum
Shade: PC- Polycarbonate
Diffuser: PC- Polycarbonate

LED Colour Temperature

Static White
2700 K; 3000 K; 3500 K
Tunable White (2200 K - 4000 K)
CRI>90

Control

Analog: On/Off; Push
Digital: DALI-2; DALI-2 DT8
Smart: Casambi

Electrical connection

Built-in (Driver included)



3360

Ø 36 cm



3363

Ø 47 cm



↑ IP20
↓ IP40



Top



Design by Ramos & Bassols.

Soft, spherical shapes and a warm luminescence characterize the Top collection. Its glowing epicenter is encircled by a larger ring, framing the light within its pure geometry.

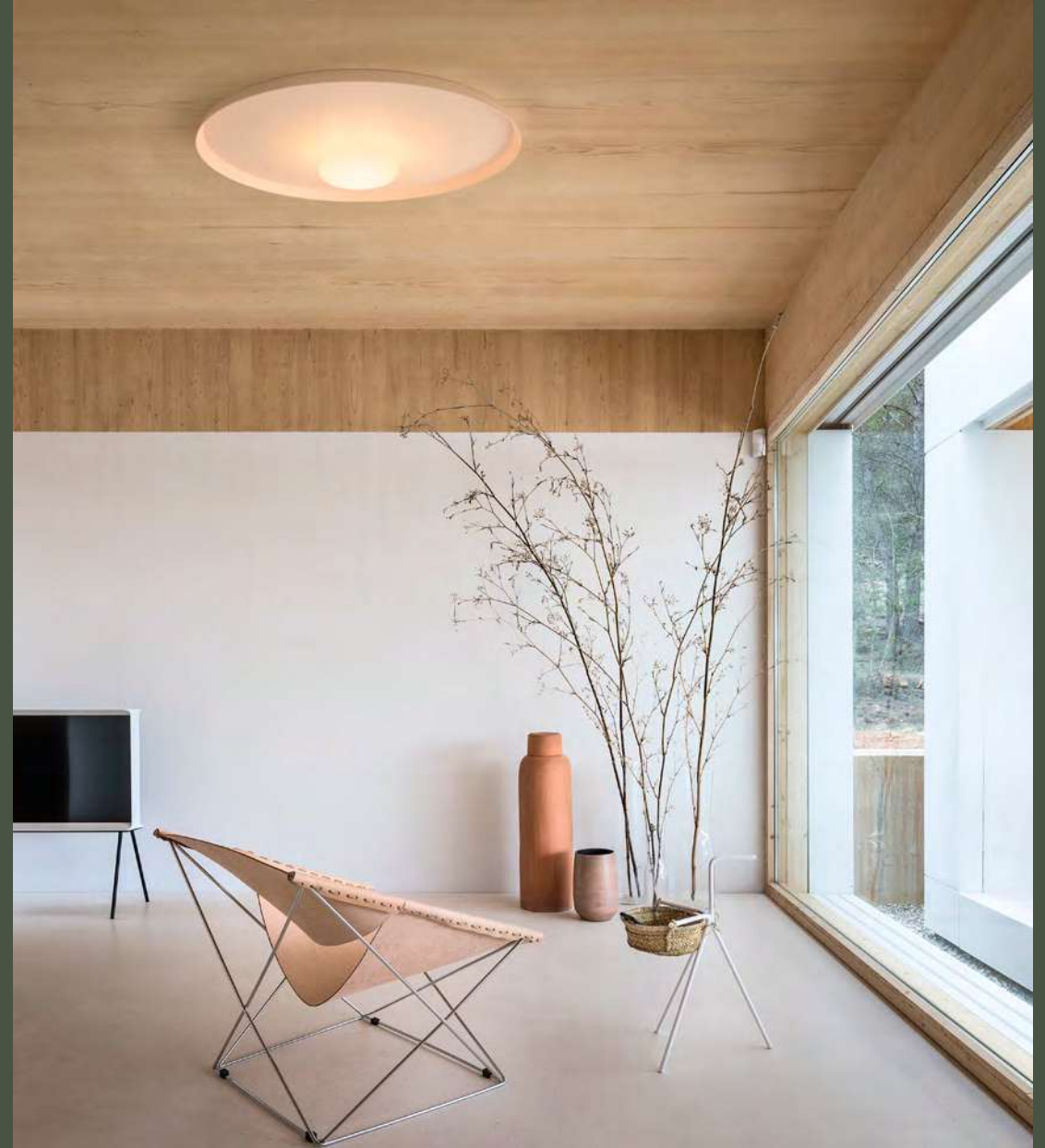

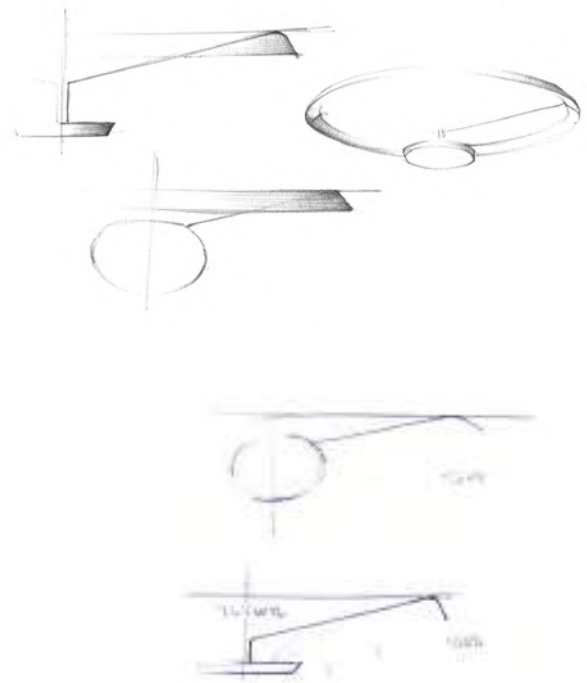

A contemporary take on the traditional rosette motif, Top is defined by a pair of concentric circles that combine to produce a halo of ambient, indirect light.





1160

Ø 60 cm

1170

Ø 90 cm

Top distills the timeless rosette down to its essence. A pair of simple circles creates a pulsing nucleus of LED-powered light overhead. The smaller illuminated sphere projects light outwards towards the larger one, creating a halo of even, indirect light and generating a soothing atmosphere.

- 10 White (NCS S 0300-N)
- 36 Soft Pink (NCS S 1010-Y50R)
- 40 Blue L1 (NCS S 3010-B)
- 47 Green L1 (NCS S 4005-G80Y)

Body: Aluminum
 Ref. 1170
 Diffuser: Triplex Opal Glass

LED Colour Temperature

2700 K; 3500 K
 CRI>90

Control

Analog: Push; 1-10V;
 Digital: DALI-2
 Smart: Casambi

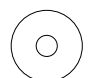

Circus

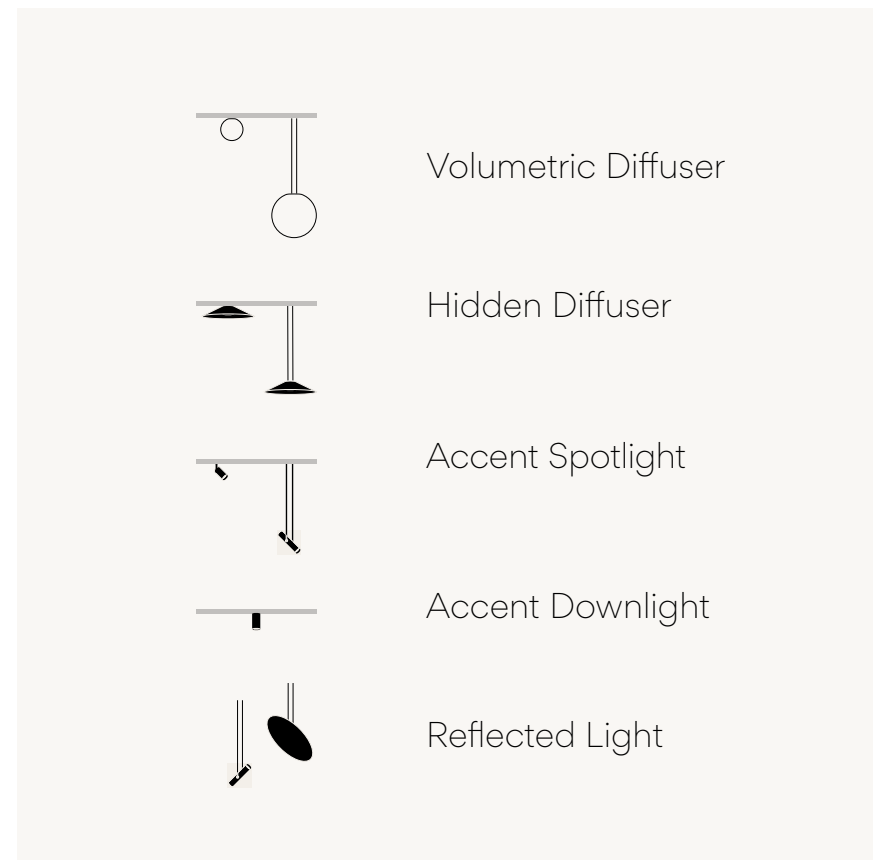

Design by Antoni Arola.

A creative toolkit full of possibilities to explore and enjoy, Circus offers total freedom of composition, multiple components and a myriad of diffuse, accented and reflected lighting effects. Inspired by the tension and dynamics of a trapeze act, the collection is defined by its minimalist structure and signature conductive bar, delicately balanced by opposing elements to create a joyful festival of light.

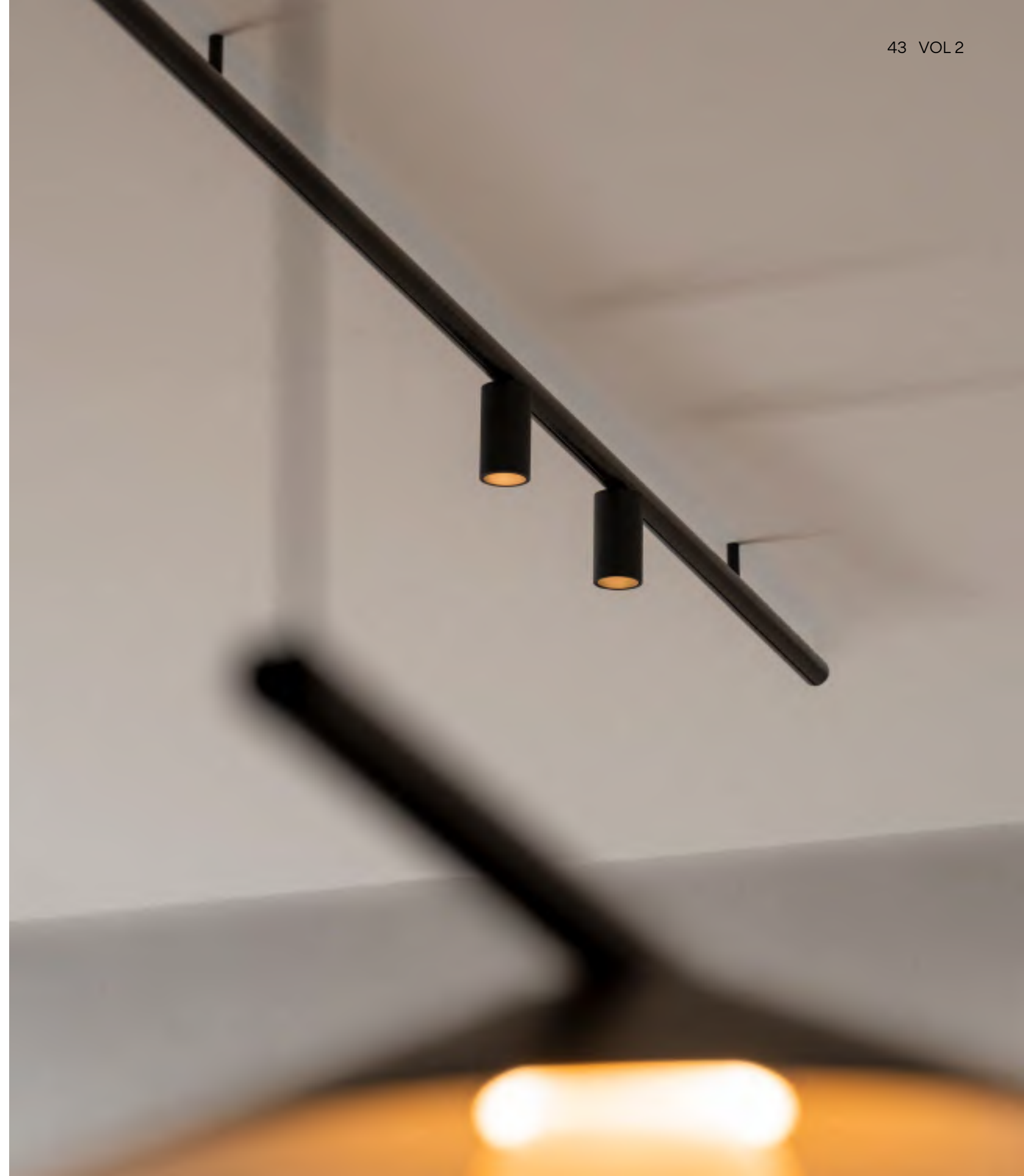

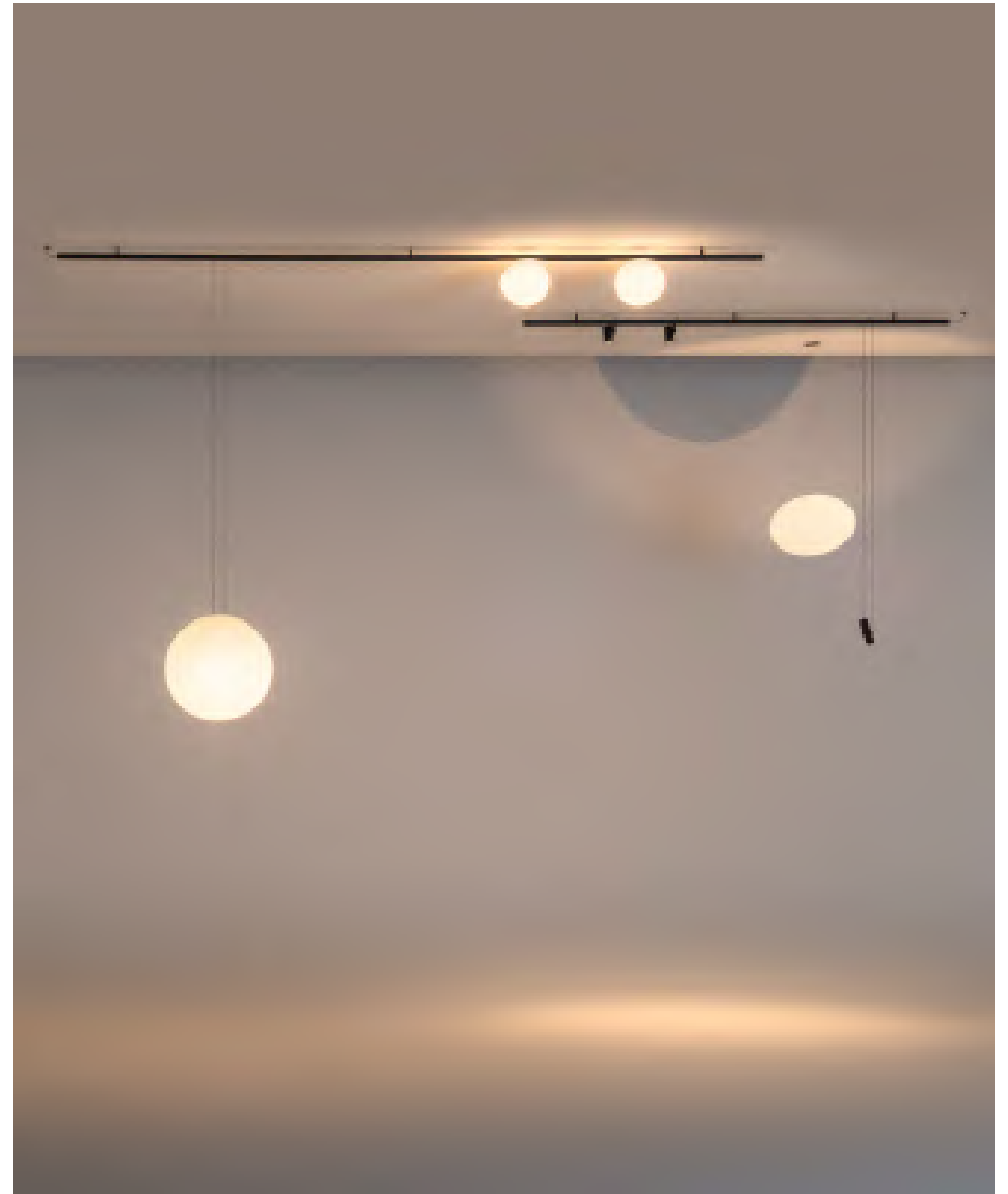



Often considered the heart of any home, the kitchen serves as a space for preparing food, for cooking, and for eating.

But it also transcends its functional purpose.

The act of eating creates an opportunity for people to gather together. It is a social space, a meeting point for the entire family, and a manifestation of cultural traditions.

A good kitchen should combine functionality with aesthetics, embracing the many different uses we have for our kitchens today. Circus allows the designer to play with different lighting effects, introducing a variety of fixtures that can be built into the conductive bar, suspended from a track or hung directly from the surface of the ceiling. Go to vibia.com to find the best solution for your project.

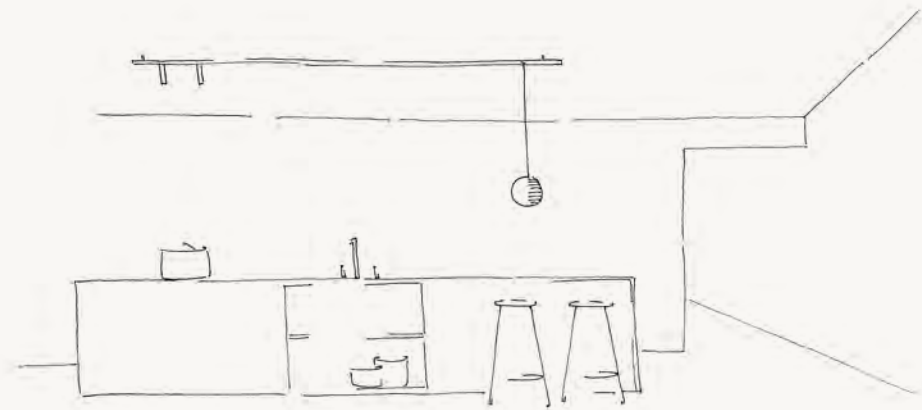



Spots and downlights can be used to play with contrasts, define functional areas or highlight key aspects of a space. Thanks to their capacity for adaptation, rotation, and different degrees of lens aperture, Circus spotlights accommodate different functions. The narrower the beam, the more specular the light becomes, creating dynamic visual hierarchies with darker shadows and intense highlights.

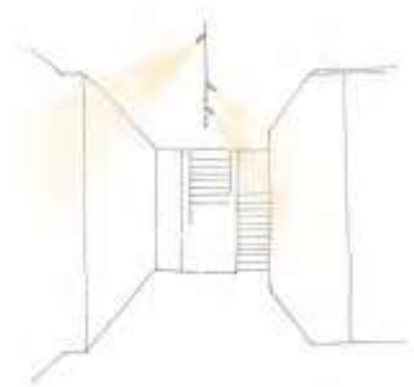

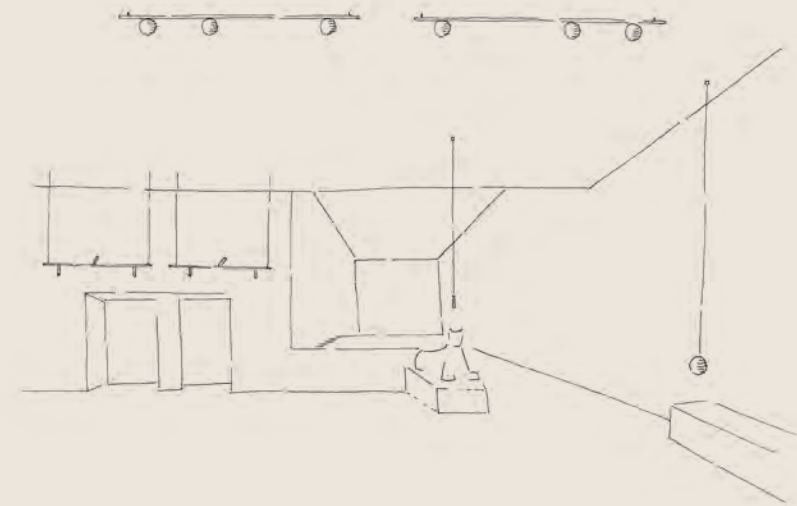

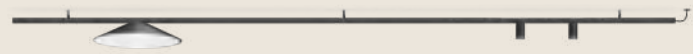



The bar amplifies the possibilities for shaping a space by conducting electricity and transporting light to wherever it is needed, turning the professional into a composer of atmospheres.

The track is available in two sizes and the electrical connection piece is concealed to adapt to all kinds of ceilings. A choice of two versatile finishes ensures the collection adapts to any interior style.

- 11 Black (NCS S 8500-N)
- 24 Beige M1 (NCS S 2005-Y50R)

Electrical connection options



Surface Built-in Remote

Ceiling Tracks

A352 210 cm



A355 300 cm

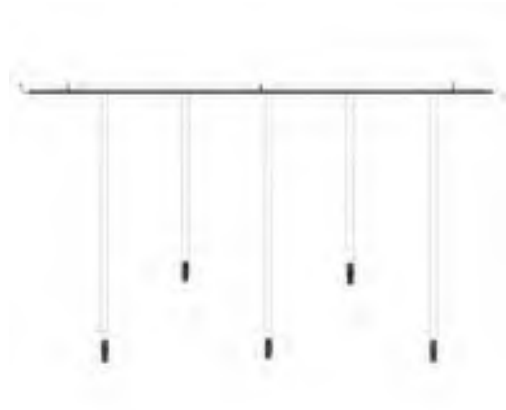

Developed both vertically and horizontally, the system combines spots, reflective discs and a range of striking diffusers to create a perfect synthesis of atmospheres. With a traditional light rail the connection is visible from below, but with Circus, the luminaires are connected to the bar from above and sealed with cover, significantly enhancing the aesthetic purity of the design.

- 11 Black (NCS S 8500-N)
- 24 Beige M1 (NCS S 2005-Y50R)

Volumetric Diffuser

Diffuser: PE- Polyethylene

Hidden Diffuser

Shade: Aluminum

Diffuser: PC- Polycarbonate

Spots / Downlight

Body: Aluminum

Lens: PMMA

Pendant Spot

Body: Zinc Alloy

Lens: PMMA



LED Colour Temperature

Volumetric Diffuser / Hidden Diffuser

Static White

2700 K; 3000 K; 3500 K

Tunable White (1800 K- 4000 K)

Tunable Red (Red - 2700 K)

Spots / Downlight

Static White

2700 K - 680 lm

3000 K - 711 lm

3500 K - 737 lm

7,2W

Only ref. 0136, 0137, 0141,

0142, 0152 and 0153

Tunable White (1800 K - 4000 K)

Smart (P2P)

308 lm - 504 lm 5,5W

Only ref. 0136, 0141 and 0152

Tunable Red (Red - 2700 K)

Smart (P2P)

155 lm - 581 lm 7W

CRI>90

Control

Digital: DALI-2 (P2P)

Smart: Casambi (simultaneous line);

Casambi (P2P); ProtoPixel* (P2P)

*ProtoPixel products are compatible with all other DALI-2 products via a designated gateway (please consult us)

Updated detailed spec sheets on vibia.com

Volumetric Diffuser

PENDANT

0162

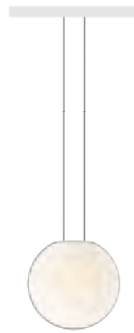

Ø 20 cm

0167



Ø 45 cm

DIRECT TO TRACK

0164



Ø 20 cm

Hidden Diffuser

PENDANT

0155

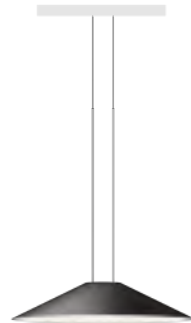

Ø 40 cm

DIRECT TO TRACK

0157



Ø 40 cm

Accent Spotlight

PENDANT

0140 Narrow
0141 Medium
0142 Wide

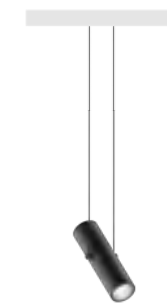

Ø 4 cm

SIDE-SPOTS

0135 Narrow
0136 Medium
0137 Wide



Ø 4 cm

Accent Downlight

DOWNLIGHTS

0151 Narrow
0152 Medium
0153 Wide



Ø 4 cm

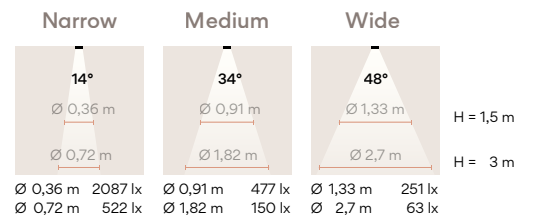

Suspended from the ceiling and positioned at any angle, a range of reflector discs reflect diffuse light from a spot angled towards them. Lustrous and ethereal, they cast a spherical shadow on the adjacent surface like a lunar eclipse.

● 11 Black
(Bottom face: White / Top face: Black)



Reflected Light

LIGHT REFLECTOR

A146



Ø 40 cm L 9 m



A147



Ø 60 cm L 9 m



Dynamic light

Dynamic light allows professionals to play with subtle degrees of intensity and colour temperature to recreate a subtle ambience for every scene within a lighting project

A source of emotion

Static, tunable white and tunable red

Designing an atmosphere of wellbeing is based on two main axes: **space** and **time**. The axis of time implies the concept of dynamic light.

Atmosphere design is intentional, depending on the **design of different scenes according to the specific use of a space** as it evolves throughout the day. Light is dynamic because ambience also depends **on the time of day** and on the influence of the natural light at every moment.

Throughout the day our circadian rhythms respond primarily to light, which regulates our sense of physical and mental wellbeing.

Vibia's approach to coloured light invites the use of colour and intensity to create and experience different atmospheres, making them as natural and subtle as possible.

Colour is a source of emotion, it can instantly set a mood, convey a feeling or generate a sense of wellbeing.



Circus product options offer a range of static white in three different temperatures as well as the option of tunable white. Tunable lighting allows for comprehensive temperature regulation: colour temperature can be precisely tuned depending on the desired atmosphere for every scene.

The **tunable red** option allows you to glide from red to white, exploring a range of relaxing and cosy effects. Tunable white lighting option allows for comprehensive temperature regulation depending on the atmosphere of every scene.

Static White

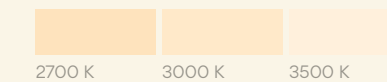

Tunable White

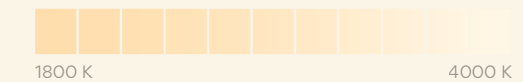

Tunable Red



Contact Vibia Support Service at vibia.com for any kind of assistance or recommendation when designing an atmosphere of wellbeing, or if you require support with control system approach.

Circus Solo

Accent Spotlight

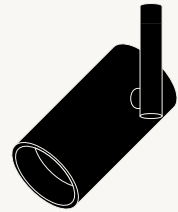

Circus Solo features a remote or built in accent spot that can be used to play with contrasts, define functional areas or highlight key aspects of a space. By mixing accent, reflected and diffuse lighting, the Circus system allows professionals to experiment with light density, creating multiple scenes within a single space.





Accent Spotlight

- 11 Black (NCS S 8500-N)
- 24 Beige M1 (NCS S 2005-Y50R)

Body: Aluminum
Lens: PMMA
Snoot: PC- Polycarbonate

LED Colour Temperature

Static White
2700 K - 680 lm
3000 K - 711 lm
3500 K - 737 lm
7,2W

Only ref. 0172, 0173
Tunable White (1800 K - 4000 K)
Smart
308 lm - 504 lm 5,5W

Only ref. 0172
Tunable Red (Red - 2700 K)
Smart
155 lm - 581 lm 7W

CRI>90

Control

Analogue: On/ Off; Push
Digital: DALI-2*
Smart: Casambi

*DALI-2 products are compatible (via a designated gateway) with all ProtoPixel dynamic-light solution products.

Electrical connection options



Remote Built-in
Micro

Driver included

Visit vibia.com to group several pieces with just one electrical point



SPOTS (REMOTE / BUILT-IN)

0171 Narrow
0172 Medium
0173 Wide

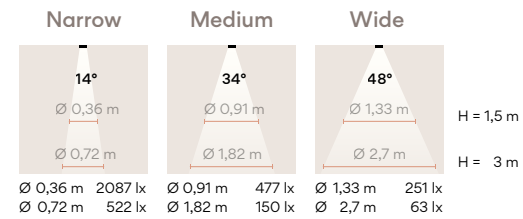
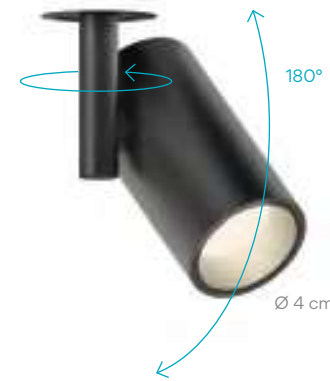
Static,
tunable white
and tunable red

Circus product options offer a range of static white in three different temperatures as well as the option of tunable white. Tunable lighting allows for comprehensive temperature regulation: colour temperature can be precisely tuned depending on the desired atmosphere for every scene.

The **tunable red** option allows you to glide from red to white, exploring a range of relaxing and cosy effects. Tunable white lighting option allows for comprehensive temperature regulation depending on the atmosphere of every scene.

Static White

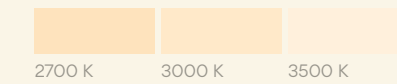

Tunable White

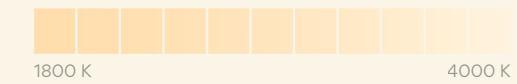

Tunable Red

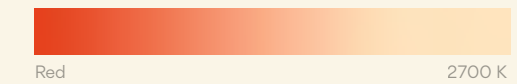

Contact Vibia Support Service at vibia.com for any kind of assistance or recommendation when designing an atmosphere of wellbeing, or if you require support with control system approach.

Flat



Design by Ichiro Iwasaki.

A study in geometry, the Flat collection features distinctive, disc-shaped diffusers that form horizontal planes of light, infusing a space with pools of soft illumination.

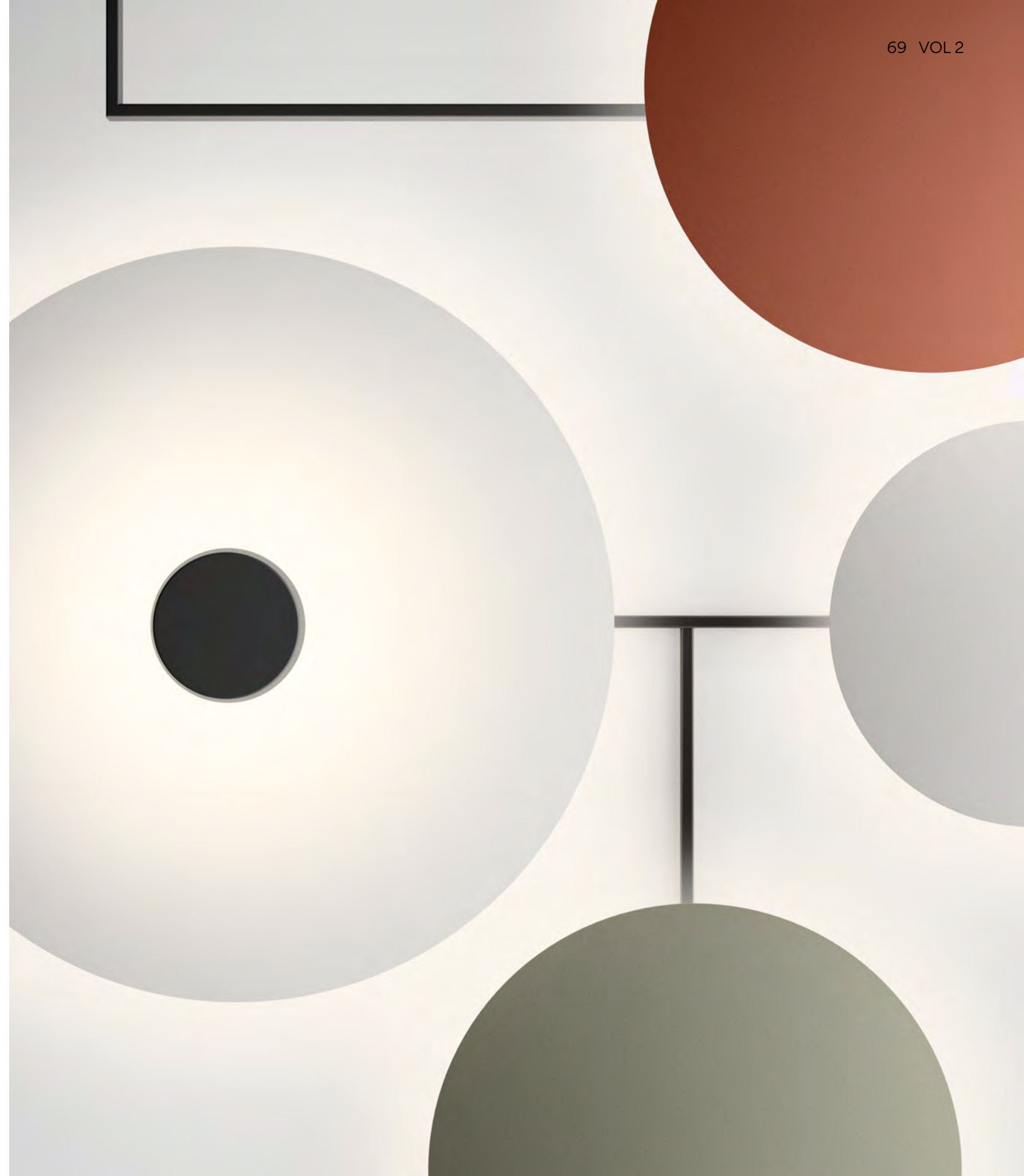





"A reflector lamp collection that connects a floating light source with a linear structure. Minimal reflector discs and linear structure provide simple and powerful universality like alphabets and musical scores".

Ichiro Iwasaki

5920
Ø 40 cm



5915
Ø 55 cm



5926
Ø 90 cm



*5922
178 x 149 cm

*5905
101 x 88 cm



*5924
186 x 149 cm

*5910
106 x 90 cm



Ref. 5922

10 White (NCS S 0300-N)



71 White, Green L1, Off-White
(NCS S 0300-N, NCS S 4005-G80Y,
NCS S 1000-N)

Ref. 5924

10 White (NCS S 0300-N)



72 White, Green L1
(NCS S 0300-N, NCS S 4005-G80Y)



73 White, Off-White
(NCS S 0300-N, NCS S 1000-N)

Ref. 5926, 5915

10 White (NCS S 0300-N)

Ref. 5920

10 White (NCS S 0300-N)

13 Off-White (NCS S 1000-N)

47 Green L1 (NCS S 4005-G80Y)

Shade: Aliminum. Diffuser: PC- Polycarbonate
Structures: Steel. Canopy: Aluminum

LED Colour Temperature

2700 K; 3500 K
CRI>90

Control

Ref. 5920, 5926
Analog: Push; 1-10V
Digital: DALI-2

Ref. 5922, 5924
Analog: Push; 1-10V
Digital: DALI-2
Smart: Casambi

* One electrical connection point

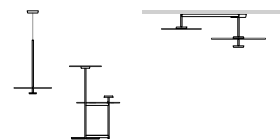

Pg 94/405 VOL 1 Pg 68 VOL 2



Line

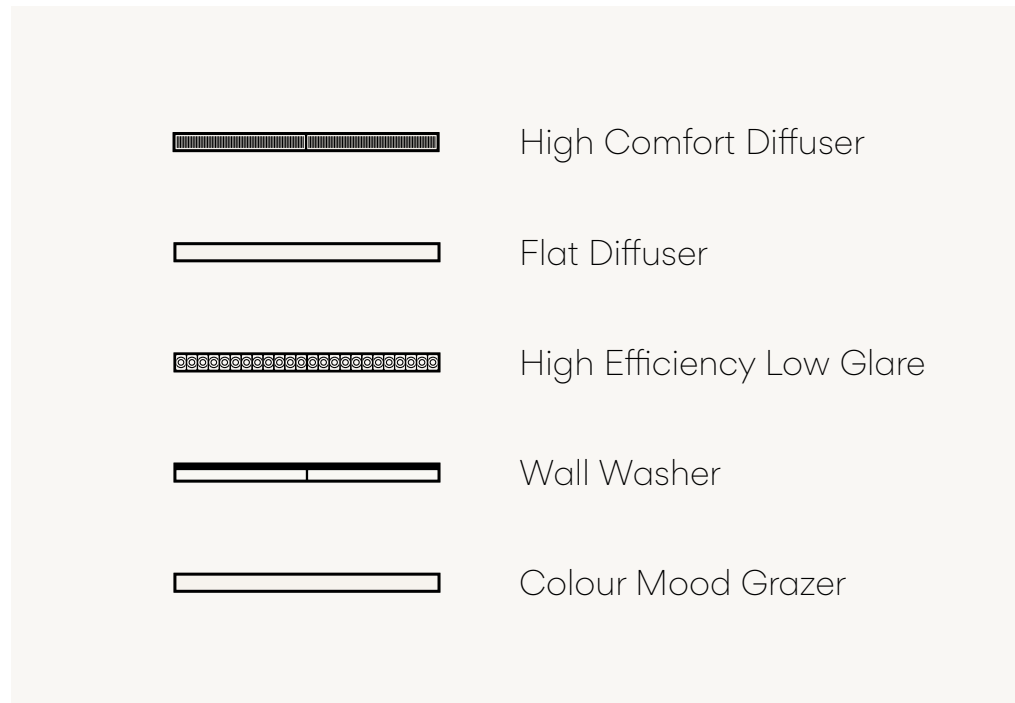

Line consists of a series of simple linear luminaires, each with a distinct lighting effect. Integrating dynamic control and subtle gradients in intensity, tone and colour, the collection complements Vibia's wider product range to curate a subtle atmosphere.

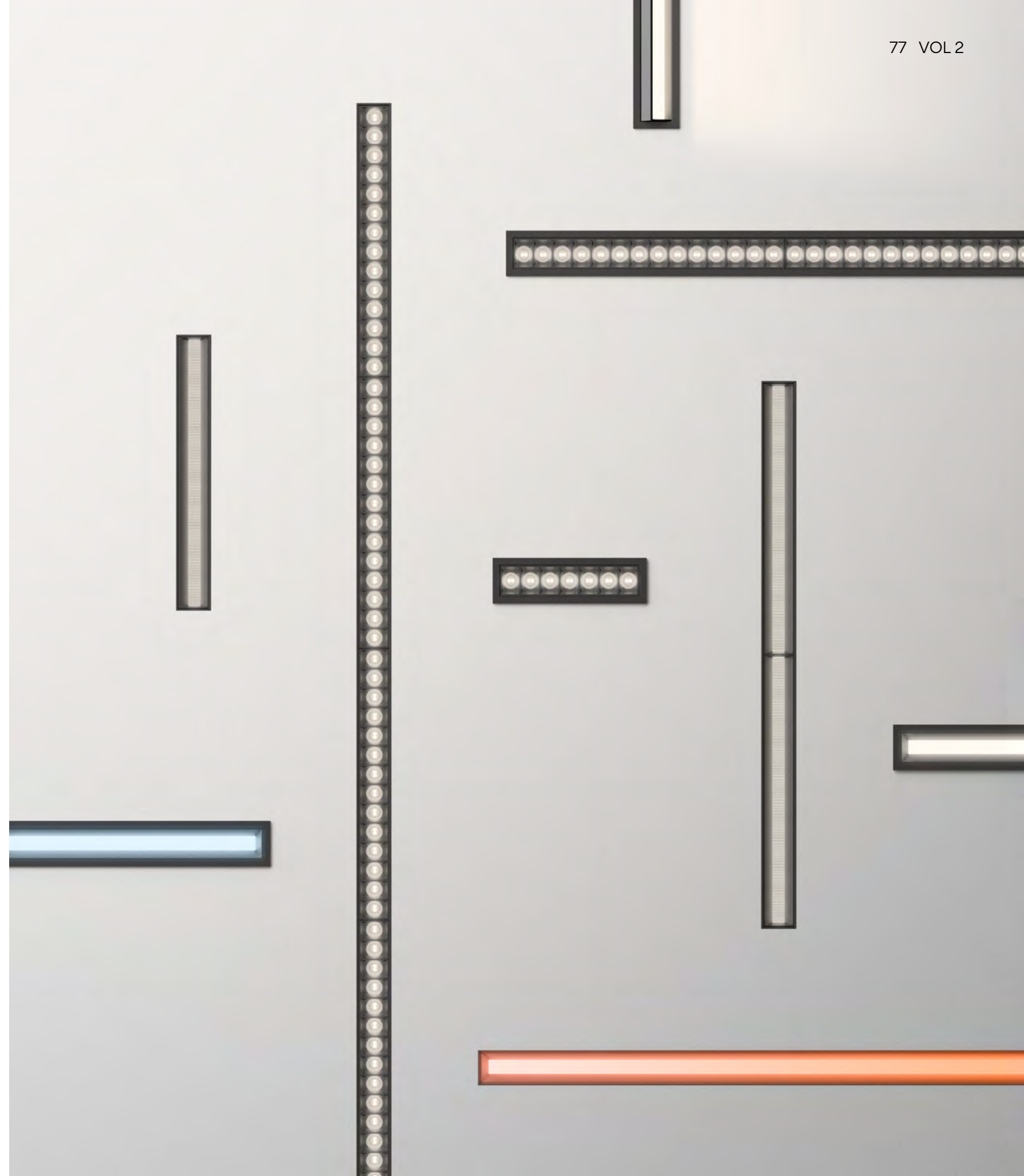

Dynamic light

Dynamic light allows professionals to play with subtle degrees of intensity and colour temperature to recreate a subtle ambience for every scene within a lighting project



Throughout the day our circadian rhythms respond primarily to light, which regulates our sense of physical and mental wellbeing

Comfortable environments

Vibia's spot accent, downlight and general lighting luminaires include the option of tunable white. Combining these zenithal tunable white lights with the rest of the diffused and indirect lighting effects of Vibia's portfolio, you can design the perfect scene for every moment and use.

Tunable lighting allows for comprehensive temperature regulation and intensity: colour temperature can be precisely tuned depending on the desired atmosphere for every scene.

Static White



Tunable White

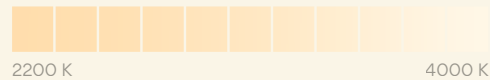

Contact Vibia Support Service at vibia.com for any kind of assistance or recommendation when designing an atmosphere of wellbeing, or if you require support with control system approach.



High Comfort Diffuser

Available in various lengths, with and without trim, and in two modest finishes, Line guarantees subtle integration within the surrounding architecture. The homogeneous quality of light from the High Comfort diffuser is designed to create a peaceful, rich and relaxing ambience, ensuring smooth lighting across the surface of the ceiling.

- 11 Black (NCS S 8500-N)
- 23 Warm White (NCS S 0502-Y50R)

Body: Aluminum / PC- Polycarbonate
 Shade: PC- Polycarbonate
 Diffuser: PE- Polyethylene
 Trimless frame: Aluminum

LED Colour Temperature

Static White
 2700 K; 3000 K; 3500 K
 Tunable White (2200 K - 4000 K)

CRI>90

UGR<21

Control

Analog: On/ Off; Push; 1-10V
 Digital: DALI-2; DALI-2 DT8
 Smart: Casambi

Electrical connection

Built-in (Driver included)

Visit vibia.com to group several pieces with just one electrical point

Updated detailed spec sheets on vibia.com

TRIMLESS

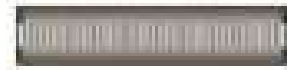

TRIM

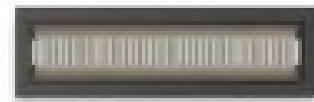

3503 Trimless 13 x 3 cm



3500 Trim 14 x 4 cm



3508 Trimless 27 x 3 cm



3505 Trim 28 x 4 cm



3513 Trimless 53 x 3 cm



3510 Trim 54 x 4 cm



3518 Trimless 102 x 3 cm



3515 Trim 103 x 4 cm





A well-illuminated work space with clearly defined areas of activity can enhance productivity, concentration and dialogue, strengthening the work-day experience and generating a collective sense of well-being. General lighting sets the tone, washing a space with comfortable uniform illumination that brightens the entire area. Task lighting, on the other hand, provides the right kind of light for a specific use. The nature and intensity of the light is determined by the intended purpose, defining clear “activity zones” within a space.

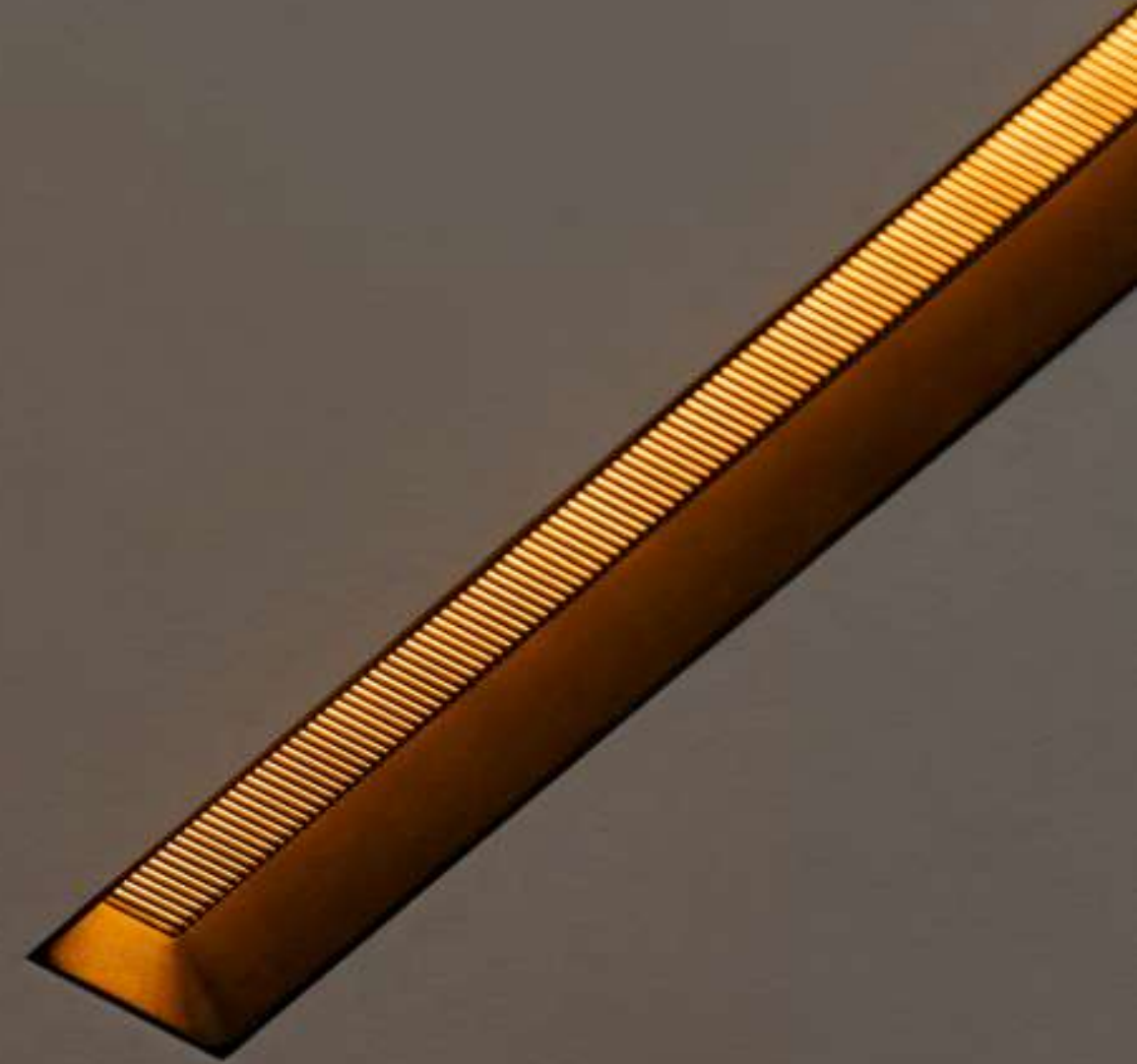

Flat Diffuser

Featuring a translucent cover to control the brightness, the Flat Diffuser creates a comfortable atmosphere by casting a pleasant, uniform light. Designers can experiment with composition, incorporating various lengths for a distinctly linear look.

- 11 Black (NCS S 8500-N)
- 23 Warm White (NCS S 0502-Y50R)

Body: Aluminum
Trimless frame: Aluminum
Diffuser: PC- Polycarbonate

LED Colour Temperature

2700 K; 3000 K; 3500 K
Tunable White (2200 K - 4000 K)
CRI>90

Control

Analog: On/ Off; Push; 1-10V
Digital: DALI-2*; DALI-2 DT8*
Smart: Casambi

*DALI-2 products are compatible (via a designated gateway) with all ProtoPixel dynamic-light solution products.

Electrical connection

Built-in (Driver included)

Updated detailed spec sheets on vibia.com

TRIMLESS



TRIM



3533 Trimless 52 x 3 cm 

3530 Trim 53 x 4 cm 

3538 Trimless 102 x 3 cm 

3535 Trim 103 x 4 cm 

3543 Trimless 202 x 3 cm 

3540 Trim 203 x 4 cm 



High Efficiency Low Glare

Respecting our natural circadian rhythms, the Linear Low-Glare High Efficiency option eliminates unwanted glare, providing soft, general lighting for a comfortable interior or subtle transition between different scenes.

TRIMLESS

TRIM

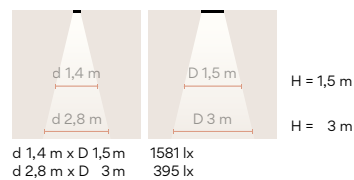
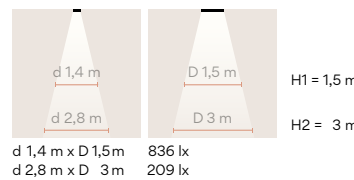
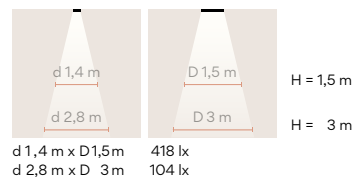
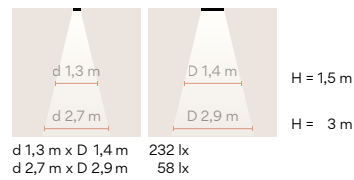
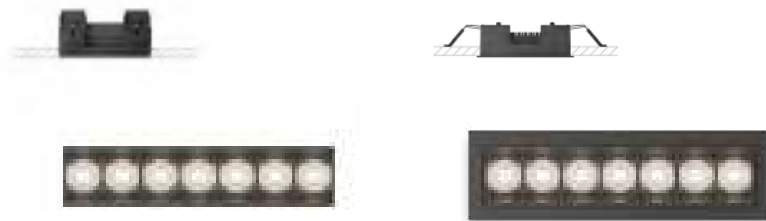

- 11 Black (NCS S 8500-N)
- 23 Warm White (NCS S 0502-Y50R)

Body: Aluminum / PC- Polycarbonate
 Shade: PC- Polycarbonate
 Diffuser: PE- Polyethylene
 Trimless frame: Aluminum

LED Colour Temperature

13 cm; 14 cm
 Static White
 2700 K - 897 lm
 3000 K - 928 lm
 3500 K - 960 lm
 7,4W
 Tunable White (2200 K - 4000 K)
 664 lm - 898 lm 7,2W

26 cm; 27 cm
 Static White
 2700 K - 1674 lm
 3000 K - 1733 lm
 3500 K - 1791 lm
 13,7W
 Tunable White (2200 K - 4000 K)
 1262 lm - 1707 lm 13,7W

51 cm; 53 cm
 Static White
 2700 K - 3348 lm
 3000 K - 3466 lm
 3500 K - 3582 lm
 27,4W
 Tunable White (2200 K - 4000 K)
 2524 lm - 3414 lm 27,4W

102 cm; 104 cm
 Static White
 2700 K - 6696 lm
 3000 K - 6932 lm
 3500 K - 7164 lm
 54,8W
 Tunable White (2200 K - 4000 K)
 5048 lm - 6828 lm 54,7W

CRI>90
 UGR<18

Control

Analog: On/ Off; Push; 1-10V
 Digital: DALI-2; DALI-2 DT8
 Smart: Casambi

Electrical connection

Built-in (Driver included)

Updated detailed spec sheets on vibia.com

Visit vibia.com to group several pieces with just one electrical point

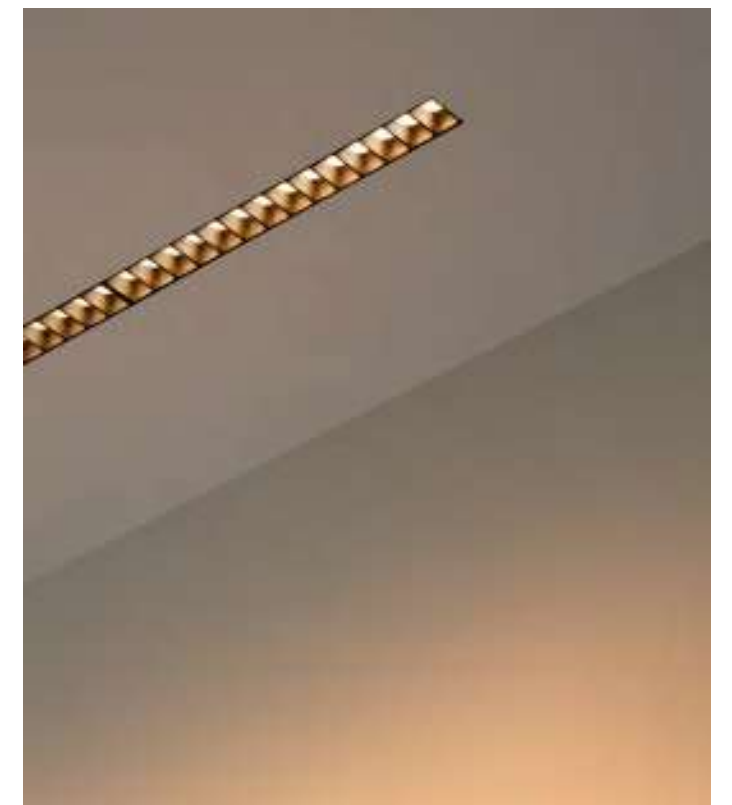

Wall Washer

A Wall Washer can be selected to illuminate a vertical surface with uniform brightness, accentuate an entrance or highlight a specific feature. Light reflected from the matte surface of the wall makes the space appear brighter and provides soft, diffuse illumination.

TRIMLESS

TRIM

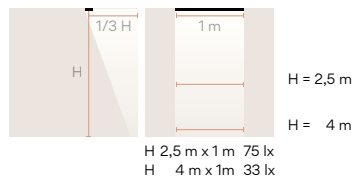
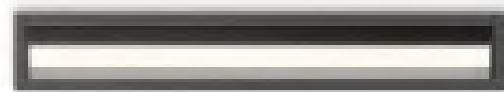

3578 Trimless

26 x 3 cm

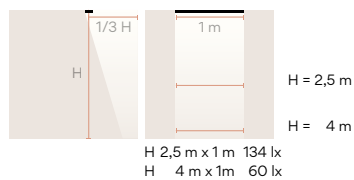

3575 Trim

27 x 4 cm

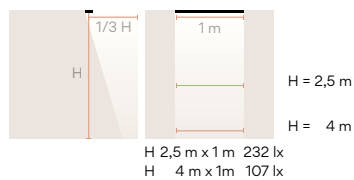

3583 Trimless

51 x 3 cm



3580 Trim

53 x 4 cm



3588 Trimless

102 x 3 cm



3585 Trim

104 x 7 cm



- 11 Black (NCS S 8500-N)
- 23 Warm White (NCS S 0502-Y50R)

Body: Aluminum / PC- Polycarbonate
 Shade: PC- Polycarbonate
 Diffuser: PE- Polyethylene
 Trimless frame: Aluminum

LED Colour Temperature

26 cm; 27 cm

Static White
 2700 K - 1392 lm
 3000 K - 1430 lm
 3500 K - 1455 lm
 13,3W

Tunable White (2200 K - 4000 K)
 764 lm - 849 lm 11,5W

51 cm; 53 cm

Static White
 2700 K - 2784 lm
 3000 K - 2860 lm
 3500 K - 2911 lm
 26,6W

Tunable White (2200 K - 4000 K)
 1528 lm - 1698 lm 23W

102 cm; 104 cm

Static White
 2700 K - 5568 lm
 3000 K - 5721 lm
 3500 K - 5822 lm
 53,2W

Tunable White (2200 K - 4000 K)
 3056 lm - 3396lm 46W

CRI>90

Control

Analog: On/ Off; Push; 1-10V
 Digital: DALI-2; DALI-2 DT8
 Smart: Casambi

Electrical connection

Built-in (Driver included)

Visit vibia.com to group several pieces with just one electrical point

Updated detailed spec sheets on vibia.com



Tunable White lighting allows for comprehensive temperature regulation. By controlling the individual LEDs, you can precisely tune the temperature from warm to cool white, depending on the desired atmosphere.

Tunable White

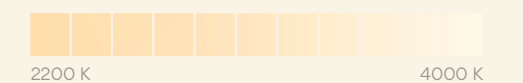

Colour Mood Grazer

Natural light is never mono-tonal. The Colour Mood Grazer is an elegant solution where either Tunable White or Infinite Colour regulation is desired. Infinite Colour incorporates six unique hues, available both as static colours or gradients, each spectrum unique to Vibia and designed to transmit a particular mood. The installer plays a fundamental role in programming the appropriate lighting mode for the space and its desired use.

- 11 Black (NCS S 8500-N)
- 23 Warm White (NCS S 0502-Y50R)

Body: Aluminum / PC- Polycarbonate
 Shade: PC- Polycarbonate
 Diffuser: Polyethylene
 Trimless frame: Aluminum



LED Colour Temperature
 Infinite Colour (TW + RGB)
 CRI>90

Control
 Smart: ProtoPixel*
 *ProtoPixel products are compatible with all other DALI-2 products via a designated gateway (please consult us)

Electrical connection
 Built-in (Driver included)

Updated detailed spec sheets on vibia.com

TRIMLESS

TRIM



3608 Trimless 100 x 3 cm

3605 Trim 103 x 4 cm

3613 Trimless 202 x 3 cm

3610 Trim 203 x 4 cm

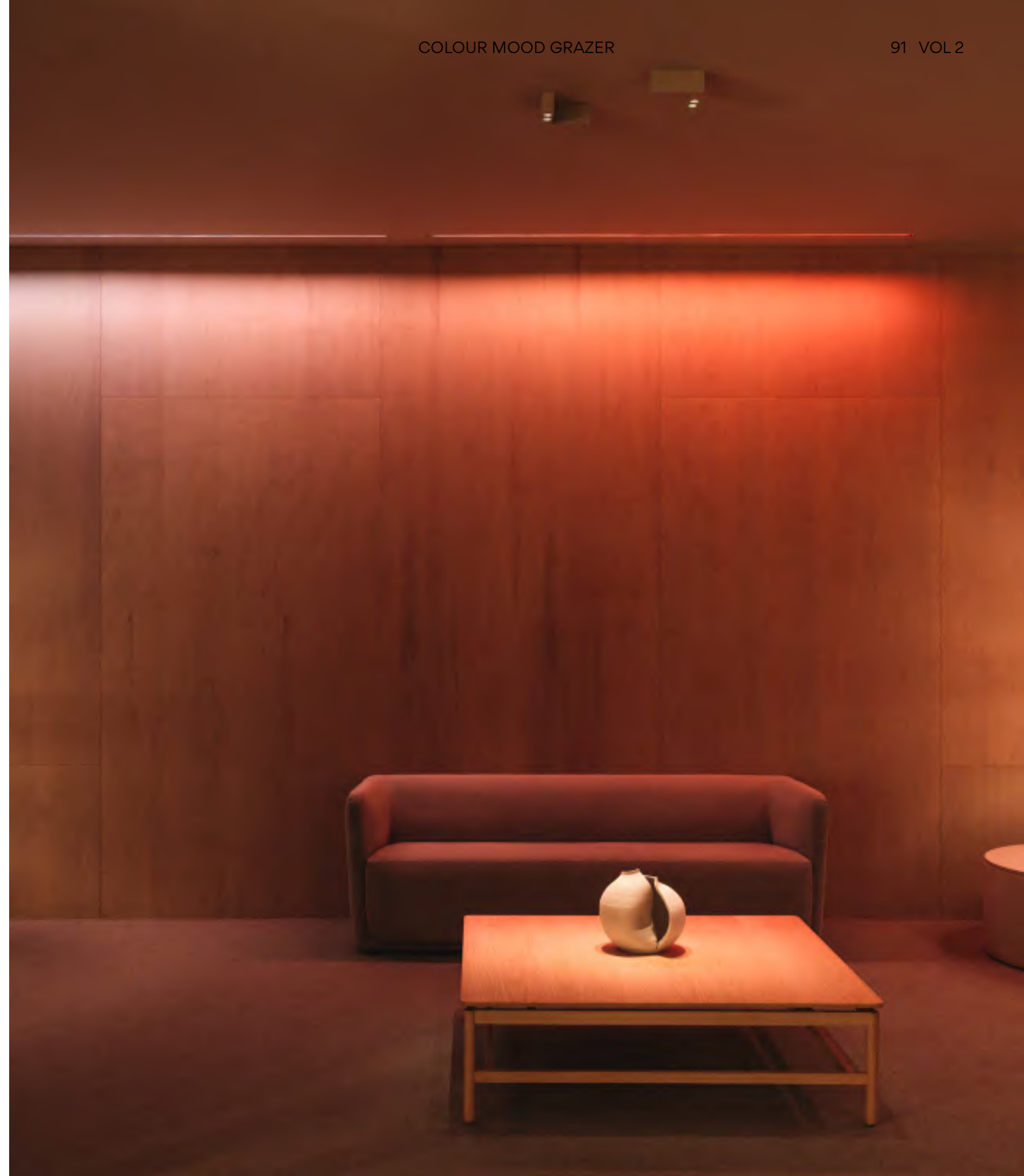

A source of emotion

Colour is a source of emotion it can instantly set a mood, convey a feeling or generate a sense of wellbeing

Vibia's approach to coloured light invites the use of colour and gradients to create and experience different atmospheres, making them as natural and subtle as possible. Natural light is never mono-tonal. Gradients come in infinite colours.

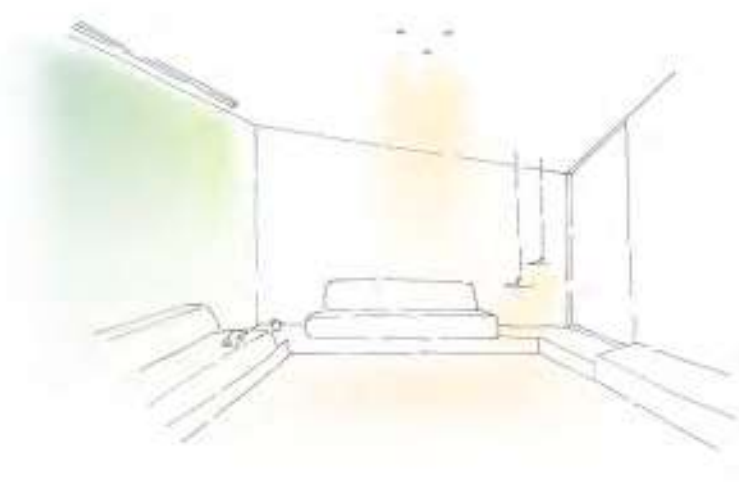

Vibia Chromatica colours of light

Static White

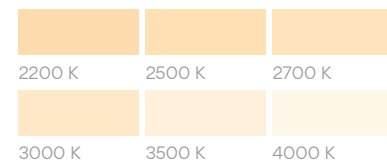



You can integrate your lighting selection into the control system for specific scene design and activate it also using the Vibia App.

Colour Moods

- 

Still - A pale and thin green light, inspired by the very first rays of morning sun
- 

Vivid - A vibrating blue with a hint of pale yellow for a feeling of liveliness
- 

Delicate - A warm and glowing orange-yellow hue, reminiscent of afternoon sun spilling through the window
- 

Cozy - Bringing a glowing warmth, this orange-red hue contains darker, moodier undertones
- 

Intense - A powerful and bold red. Not just a striking colour, but deep and nuanced
- 

Illusive - An alluring and intriguing blue light that lends an energised, almost magical feel to a space

Contact Vibia Support Service at vibia.com for any kind of assistance or recommendation when designing an atmosphere of wellbeing, or if you require support with control system approach.

Still colour mood

Light and airy, with a softness that suggests the quiet moment before a new beginning. A pale and thin green light, inspired by the very first rays of morning light. The gradient has a hint of blue to it.

Offset

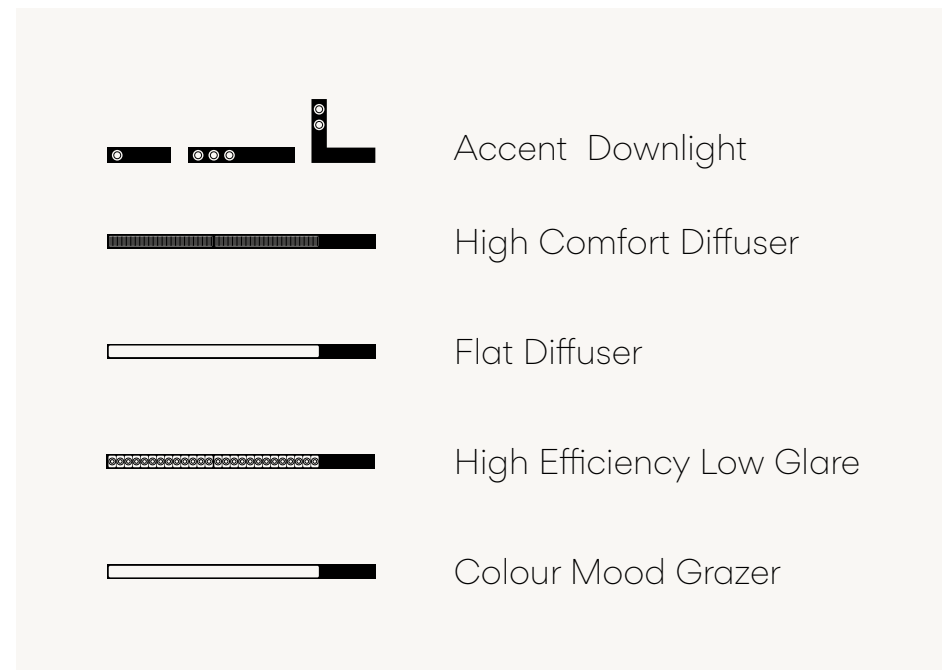

Design by Xuclà.

Offset combines intuitive lighting with an industrial, geometric silhouette. A complementary system of superficial ceiling fixtures, the collection integrates five lighting effects with advanced colour and temperature regulation for a carefully curated atmosphere.



Dynamic light

Dynamic light allows professionals to play with subtle degrees of intensity and colour temperature to recreate a subtle ambience for every scene within a lighting project

Designing an atmosphere of wellbeing is based on two main axes: **space** and **time**. The axis of time implies the concept of dynamic light.

Atmosphere design is intentional, depending on the **design of different scenes according to the specific use of a space** as it evolves throughout the day. Light is dynamic because ambience also depends **on the time of day** and on the influence of the natural light at every moment.

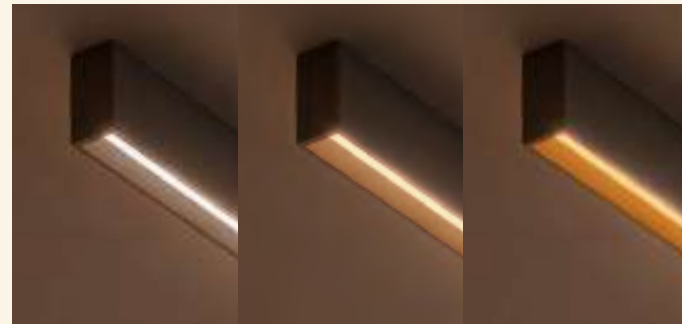

Throughout the day our circadian rhythms respond primarily to light, which regulates our sense of physical and mental wellbeing

Comfortable environments

Vibia's spot accent, downlight and general lighting luminaires include the option of tunable white. Combining these zenithal tunable white lights with the rest of the diffused and indirect lighting effects of Vibia's portfolio, you can design the perfect scene for every moment and use.

Tunable lighting allows for comprehensive temperature regulation and intensity: colour temperature can be precisely tuned depending on the desired atmosphere for every scene.

Static White



Tunable White

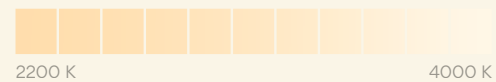

Contact Vibia Support Service at vibia.com for any kind of assistance or recommendation when designing an atmosphere of wellbeing, or if you require support with control system approach.



Accent Downlight

A complementary system of graphic fixtures, Offset accommodates ceilings that don't allow for recessed fittings. Ideal for transitional spaces, the accent downlight is visually compact. Pinpoints of light set into its robust aluminium casing attract a relaxed gaze towards the illuminated surface. Designers can experiment with composition, incorporating various lengths and angles to create a distinctly modular design.

- 11 Black (NCS S 8500-N)
- 23 Warm White (NCS S 0502-Y50R)
- 24 Beige M1 (NCS S 2005-Y50R)

Body: Aluminum

LED Colour Temperature
2700 K; 3000 K; 3500 K
285 lm 2,9W
CRI>90

Control

Analog: Push
Digital: DALI-2
Smart: Casambi; ProtoPixel*

*ProtoPixel products are compatible with all other DALI-2 products via a designated gateway (please consult us)

Electrical connection

Surface (Driver included)

Updated detailed spec sheets on vibia.com

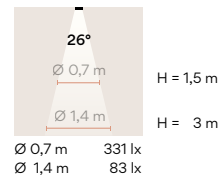

1720
15 x 4 x 7 cm

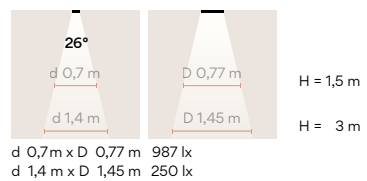

1722
25 x 4 x 7 cm

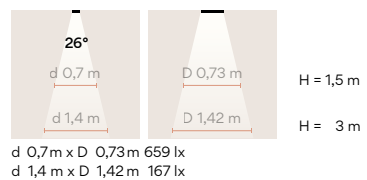

1725
15 x 15 x 7 cm



1727
15 x 15 x 7 cm

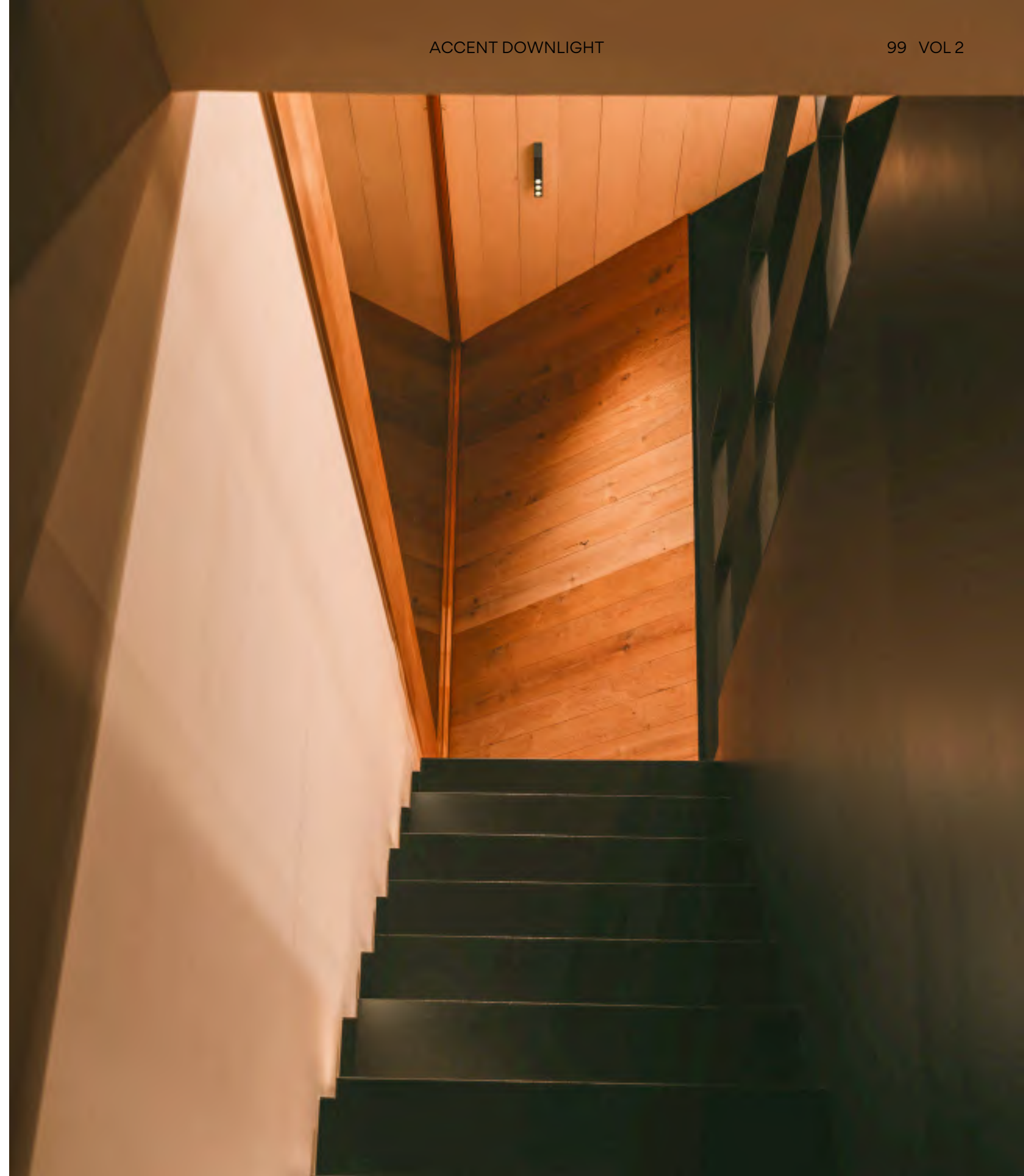



High Comfort Diffuser

Particularly suited to residential hallways or corridors, the High Comfort Diffuser comes in a broad range of lengths. The aluminium frame is fitted with high performance LED strips that provide diffuse, homogeneous illumination for a smooth and relaxed ambience.

- 11 Black (NCS S 8500-N)
- 23 Warm White (NCS S 0502-Y50R)
- 24 Beige M1 (NCS S 2005-Y50R)

Body: Aluminum
Diffuser: PC- Polycarbonate



1728
40 x 4 x 7 cm



1730
65 x 4 x 7 cm



1735
100 x 4 x 7 cm



1740
31 x 15 x 7 cm



1745
31 x 15 x 7 cm

LED Colour Temperature

Static White
2700 K; 3000 K; 3500 K
Tunable White (2200 K - 4000 K)
CRI>90

Control

Analog: Push.
Digital: DALI-2; DALI-2 DT8
Smart: Casambi; ProtoPixel*
*ProtoPixel products are compatible with all other DALI-2 products via a designated gateway (please consult us)

Electrical connection

Surface (Driver included)

Updated detailed spec sheets on vibia.com



Flat Diffuser

The Flat Diffuser guarantees a calm and comfortable atmosphere.

- 11 Black (NCS S 8500-N)
- 23 Warm White (NCS S 0502-Y50R)
- 24 Beige M1 (NCS S 2005-Y50R)

Body: Aluminum
Diffuser: PC- Polycarbonate

LED Colour Temperature

Static White
2700 K; 3000 K; 3500 K
Tunable White (2200 K - 4000 K)
CRI>90

Control

Digital: DALI-2; DALI-2 DT8
Smart: Casambi; ProtoPixel*

*ProtoPixel products are compatible with all other DALI-2 products via a designated gateway (please consult us)

Electrical connection

Surface (Driver included)

Updated detailed spec sheets on vibia.com

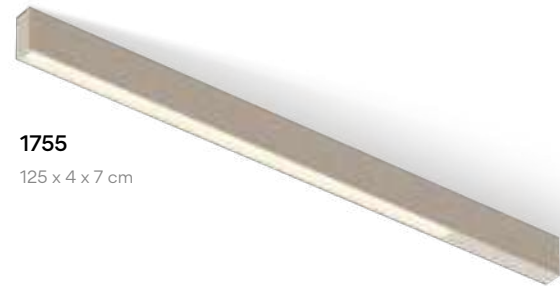

1755

125 x 4 x 7 cm



1757

225 x 4 x 7 cm





Casting a pleasant, uniform, 360° light, the Flat Diffuser ensures a calm and luminous environment

High Efficiency Low Glare

Eliminating unwanted glare, the Low-Glare High-Efficiency model provides comfortable general lighting suitable for transitional spaces and working environments such as libraries or offices.

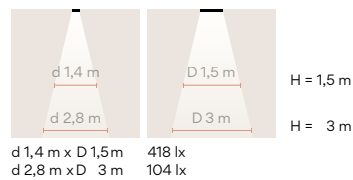
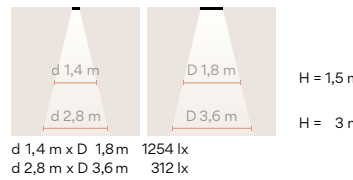
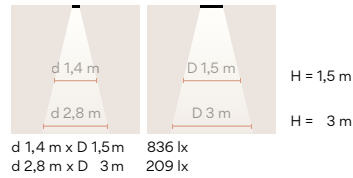
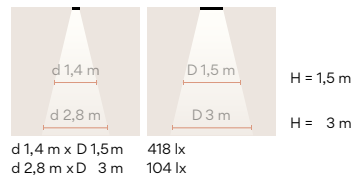

- 11 Black (NCS S 8500-N)
- 23 Warm White (NCS S 0502-Y50R)
- 24 Beige M1 (NCS S 2005-Y50R)

Body: Aluminum
Diffuser: PC- Polycarbonate

LED Colour Temperature

Ref. 1729 and 1732
Static White
2700 K - 3348 lm
3000 K - 3466 lm
3500 K - 3582 lm
20,8W 27,4W
Tunable White (2200 K - 4000 K)
1842 lm - 2150 lm 20,8W

Ref. 1737
Static White
2700 K - 5022 lm
3000 K - 5199 lm
3500 K - 5373 lm
41,1W
Tunable White (2200 K - 4000 K)
2763 lm - 3225 lm 31,2W

Ref. 1742 and 1747
Static White
2700 K - 1674 lm
3000 K - 1733 lm
3500 K - 1791 lm
13,7W
Tunable White (2200 K - 4000 K)
921 lm - 1075 lm 10,4W
CRI>90

Control
Analog: Push.
Digital: DALI-2; DALI-2 DT8
Smart: Casambi; ProtoPixel*
*ProtoPixel products are compatible with all other DALI-2 products via a designated gateway (please consult us)

Electrical connection
Surface (Driver included)

Updated detailed spec sheets on vibia.com

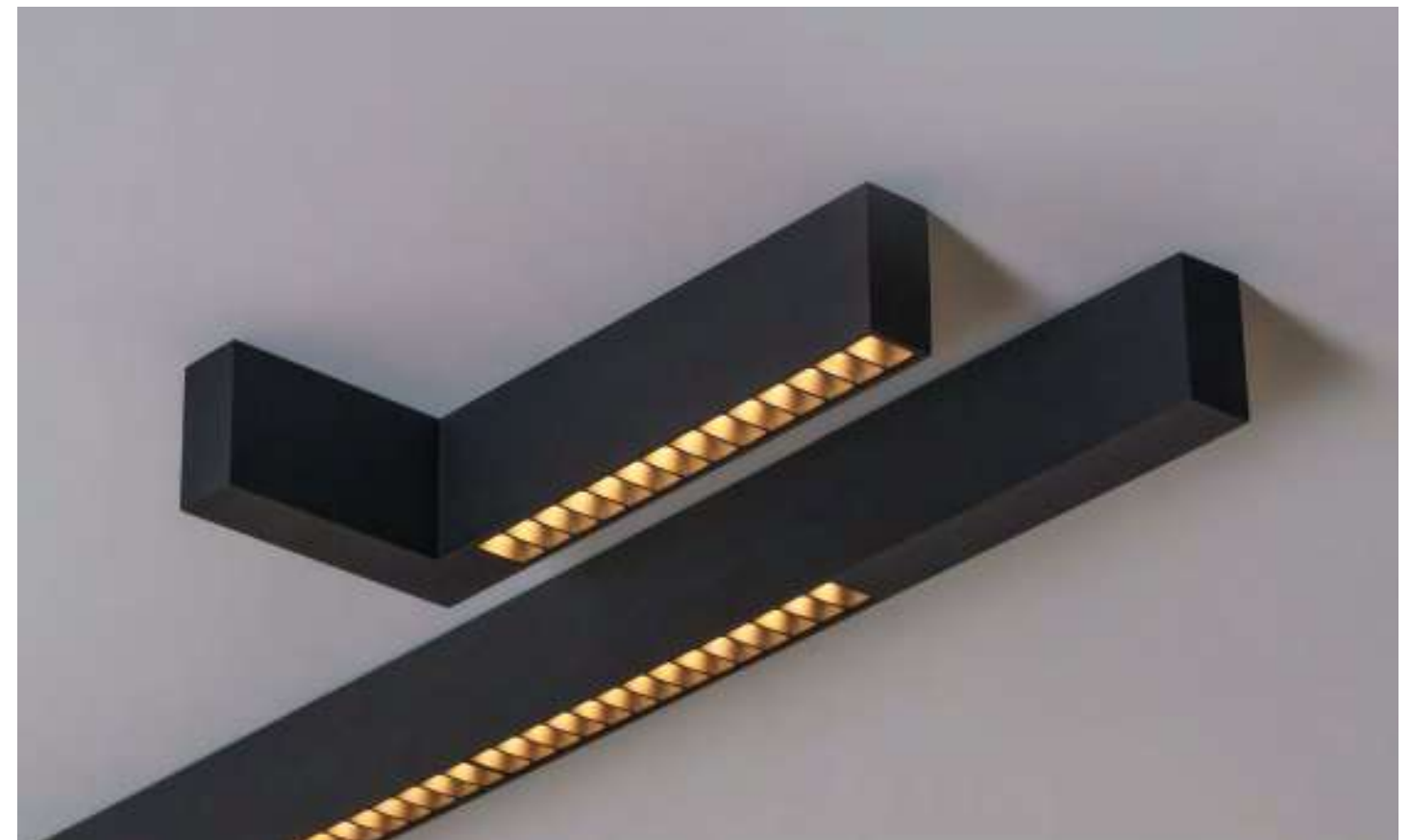



Colour Mood Grazer

Natural light is never mono-tonal. The Colour Mood Grazer is an elegant solution where either Tunable White or Infinite Colour regulation is desired. Infinite Colour incorporates six static colours and six gradients, each spectrum unique to Vibia and designed to transmit a particular kind of sensation or mood. The installer plays a fundamental role in programming the appropriate lighting mode for the space and its desired use.



- 11 Black (NCS S 8500-N)
- 23 Warm White (NCS S 0502-Y50R)
- 24 Beige M1 (NCS S 2005-Y50R)

Diffuser: PC- Polycarbonate
 Lens: PMMA



LED Colour Temperature
 Infinite Colour (TW + RGB)
 CRI >90

Control
 Smart: ProtoPixel*
 *ProtoPixel products are compatible with all other DALI-2 products via a designated gateway (please consult us)

Electrical connection
 Surface (Driver included)

Updated detailed spec sheets on vibia.com



Right Left
1760 1762
 7 x 125 x 5 cm



Right Left
1765 1767
 7 x 225 x 5 cm



Dynamic light
 Like the natural light that ascends gradually at dawn or dusk, following circadian rhythms, our infinite colour gradients add layers of visual depth and emotion, adapting to specific scenes and moods by creating a nuanced atmosphere.



A source of emotion

Colour is a source of emotion it can instantly set a mood, convey a feeling or generate a sense of wellbeing

Vibia's approach to coloured light invites the use of colour and gradients to create and experience different atmospheres, making them as natural and subtle as possible. Natural light is never mono-tonal. Gradients come in infinite colours.



Vibia Chromatica colours of light

Static White

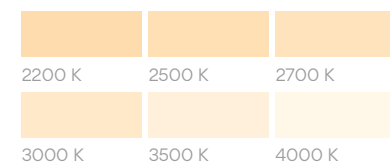

You can select any desired light -white, colour mood or gradient- and intensity manually from the analogic product interface. You can also integrate your selection into the control system for specific scene design and activate it using the Vibia App

Colour Moods

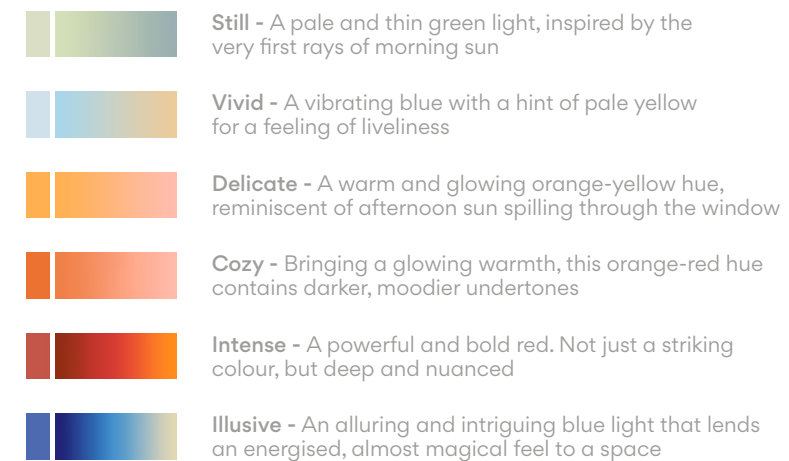

Contact Vibia Support Service at vibia.com for any kind of assistance or recommendation when designing an atmosphere of wellbeing, or if you require support with control system approach.



Palma

Design by Antoni Arola.

Antoni Arola brings an entirely new dimension to the Palma collection with a new ceiling edition. A central aluminium shaft extends vertically into the room, decorated with a choice of either two or four distinctive Palma spheres. Positioned at different heights and angles, they form an organic structure, projecting a warm, diffuse light in all directions.



3760
50 x 61 cm



3764
50 x 74 cm



● 18 Graphite (ADAPTA RF 9913 WX)

Diffuser: Blown-glass
Profile: Aluminum

LED Colour Temperature

2700 K
CRI>90

Control

Analog: Push; 1-10V
Digital: DALI-2
Smart: Casambi

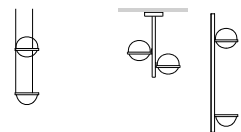

Pg 170 VOL 1 Pg 116/256 VOL 2





Plusminus Solo

Design by Diez Office.

The ceiling range can be mounted as desired, creating visual hierarchy by directing the gaze towards specific features within a space, and combined to form intriguing compositions.

Accent Spotlight



Spot Flat Diffuser

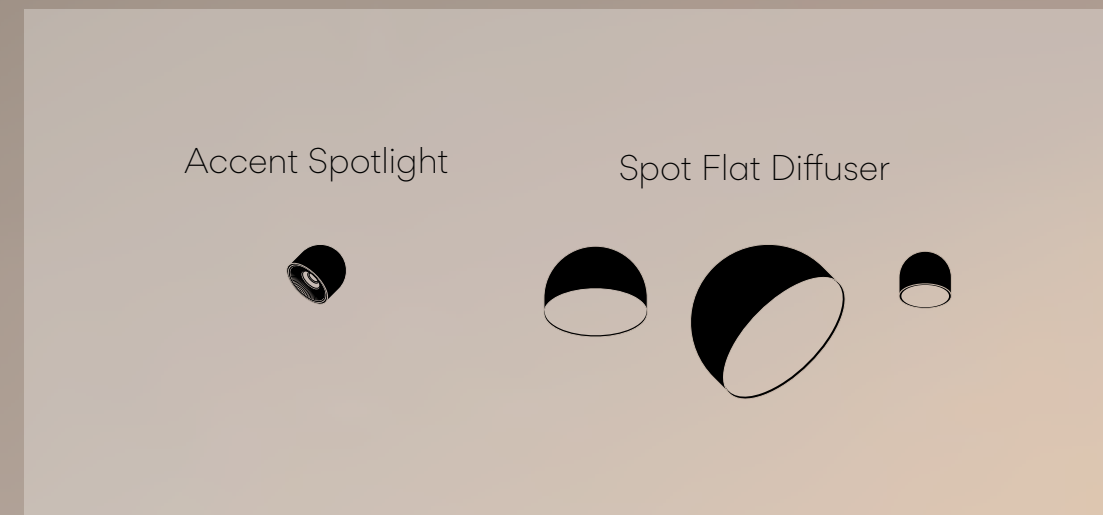



Plusminus Solo expands to include a range of surface mounted semi-spherical ceiling lights. Combining Accent Spotlights with Directed Flat Diffusers, the collection provides comfortable general lighting as well as more pointed illumination. Available in five elegant finishes, the set is designed to adapt to a range of contemporary interior styles.

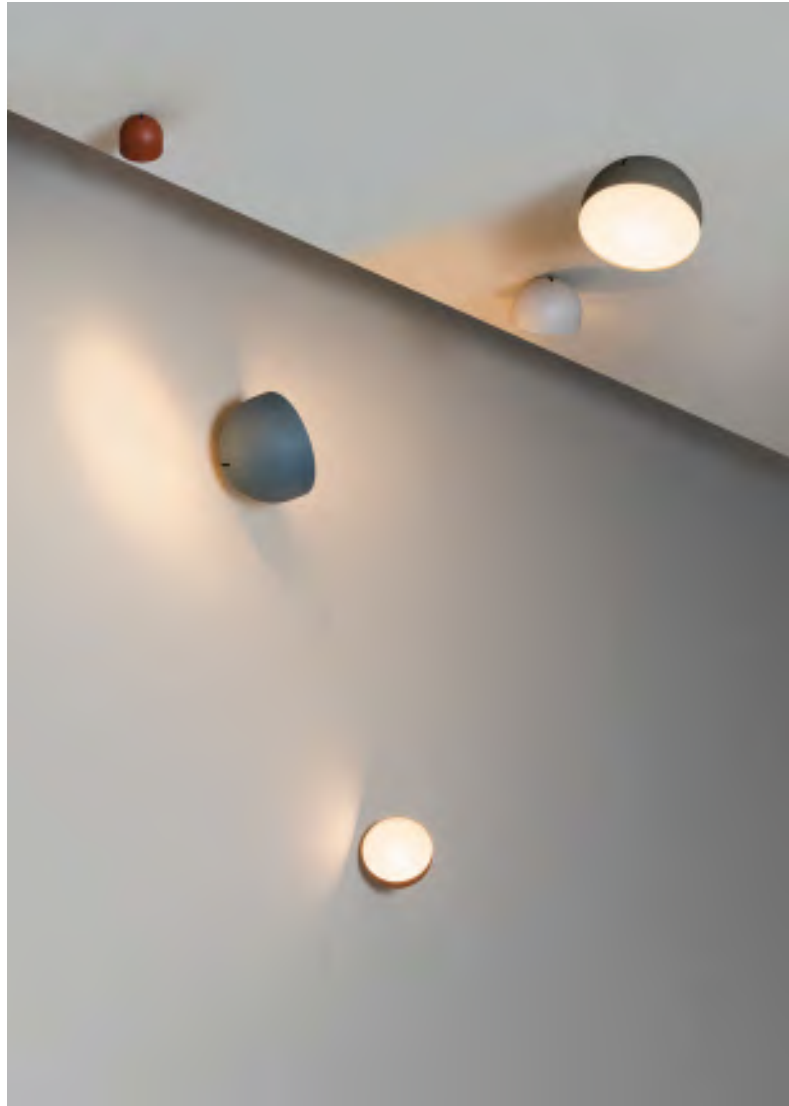

- 11 Black (NCS S 8500-N)
- 24 Beige M1 (NCS S 2005-Y50R)
- 37 Terra Red (NCS S 4040-Y70R)
- 42 Blue M1 (NCS S 5010-B10G)
- 53 Green M1 (NCS S 6005-G80Y)

Body: Aluminum
Diffuser: PC- Polycarbonate

LED Colour Temperature

Accent

2700 K - 941 lm
3000 K - 987 lm
3500 K - 1022 lm
7,9W

CRI>90

Flat diffuser

LED 2700 K; 3000 K; 3500 K

CRI>90

Control

Analog: On/ Off; Push; 1-10V

Digital: DALI-2

Smart: Casambi

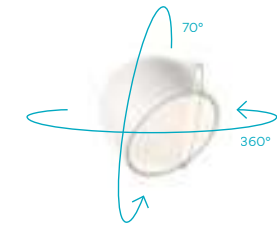

Updated detailed spec sheets on vibia.com

To see Plusminus collection go to page **p. 272 VOL 1**



Remote version Built-in

SPOTLIGHT



Accent

6330 Narrow
6331 Medium
6332 Wide
Ø 10 cm



Flat diffuser

6333
Ø 10 cm

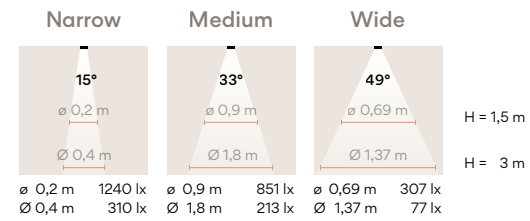

SEMISPHERE



Flat diffuser

6335
Ø 20 cm



Flat diffuser

6340
Ø 30 cm



Bind

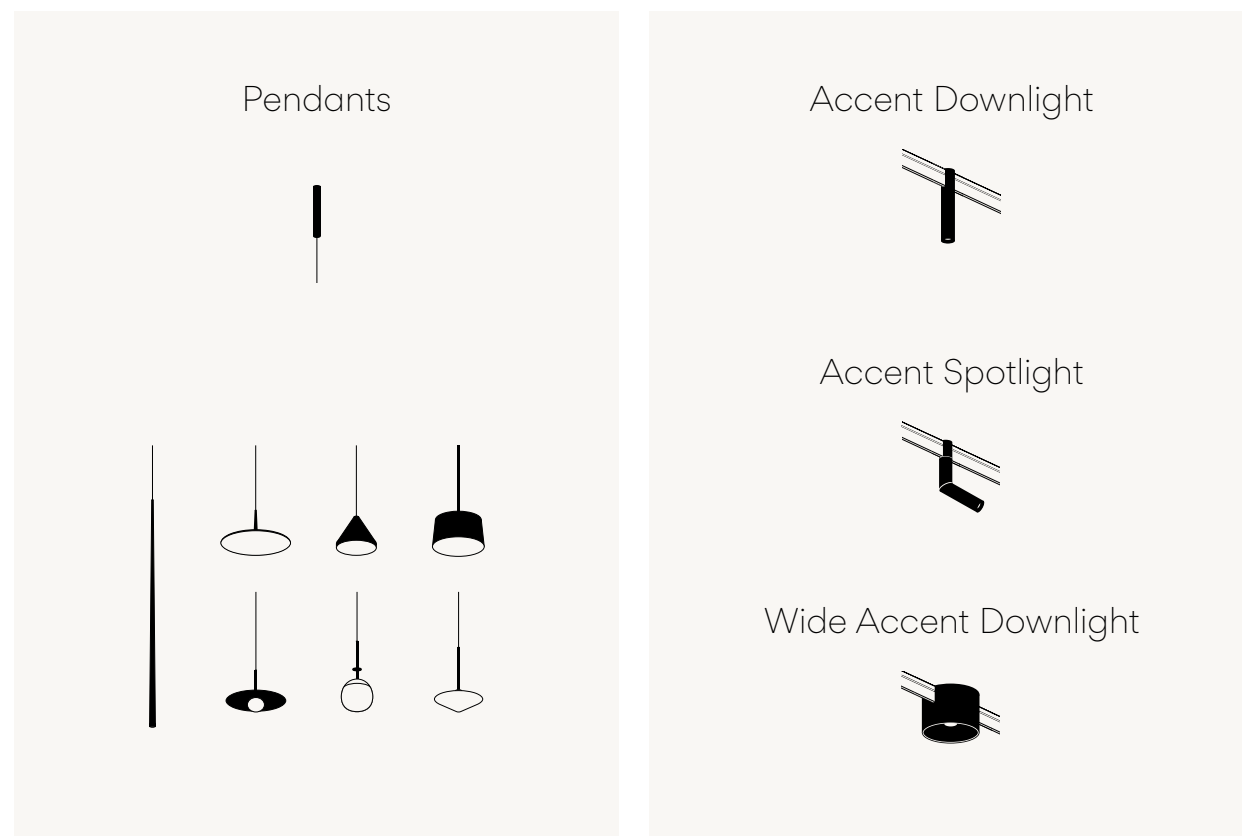

Design by Martín Azúa.

Bind is a hybrid lighting system designed to create multiple atmospheres to suit a range of spaces, uses and moods. It allows professionals to experiment with different lighting typologies and levels of density, modelling a space by generating subtle gradients between soft and more accentuated light.



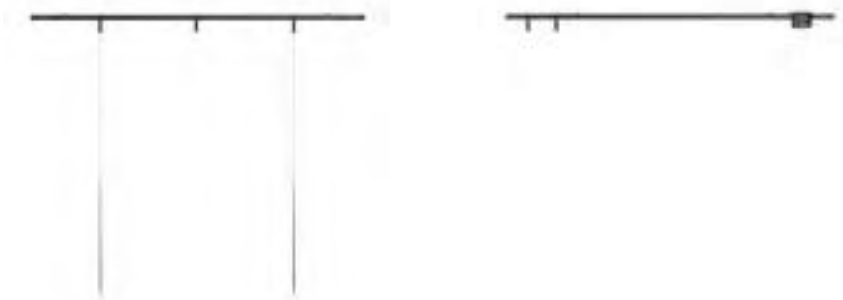



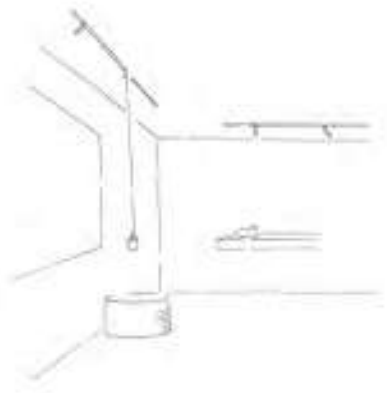
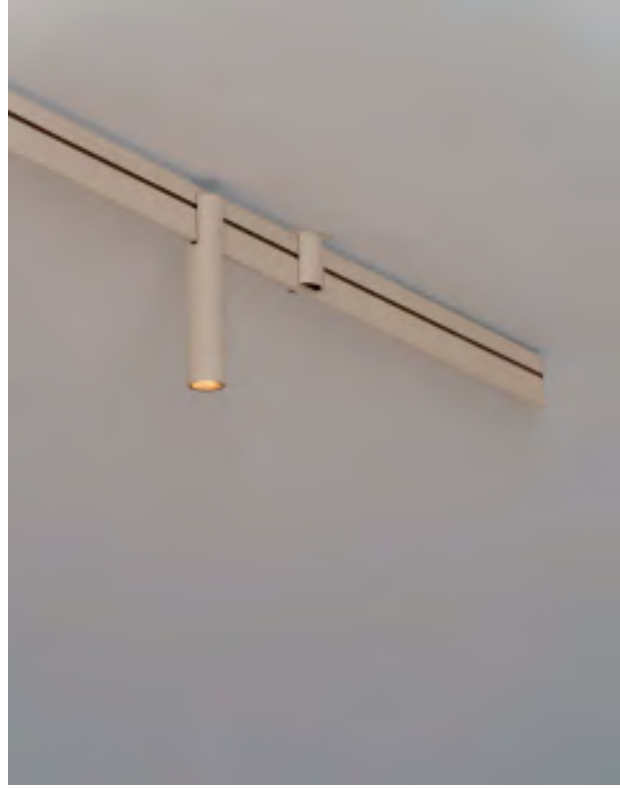



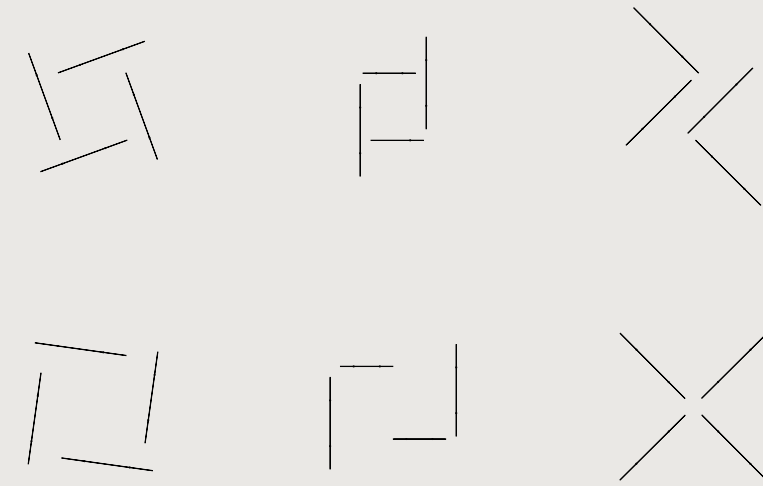

Ceiling Tracks

The Bind collection features ceiling surface track lighting as well as a range of independent elements that can be fitted directly to the ceiling. The connective quality, ease of installation and versatility of this fully modular system facilitates holistic solutions to complex demands.

- 11 Black (NCS S 8500-N)
- 24 Beige M1 (NCS S 2005-Y50R)

Track: Aluminum
Canopy: Aluminum

Electrical connection options



Surface Remote

- A491 120 cm
- A492 210 cm
- A493 300 cm



Dynamic light

Dynamic light allows professionals to play with subtle degrees of intensity and colour temperature to recreate a subtle ambience for every scene within a lighting project

Designing an atmosphere of wellbeing is based on two main axes: **space** and **time**. The axis of time implies the concept of dynamic light .

Atmosphere design is intentional, depending on the **design of different scenes according to the specific use of a space** as it evolves throughout the day. Light is dynamic because ambience also depends on **the time of day** and on the influence of the natural light at every moment.



Throughout the day our circadian rhythms respond primarily to light, which regulates our sense of physical and mental wellbeing

Comfortable environments

Vibia's spot accent, downlight and general lighting luminaires include the option of tunable white. Combining these zenithal tunable white lights with the rest of the diffused and indirect lighting effects of Vibia's portfolio, you can design the perfect scene for every moment and use.

Tunable lighting allows for comprehensive temperature regulation and intensity: colour temperature can be precisely tuned depending on the desired atmosphere for every scene.

Static White

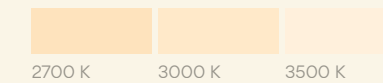

Tunable White

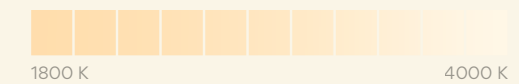

Contact Vibia Support Service at vibia.com for any kind of assistance or recommendation when designing an atmosphere of wellbeing, or if you require support with control system approach..



As a ceiling track, Bind easily integrates within the existing architecture. Multiple fixtures can be connected at any point using a pincer, oriented to direct light in various directions.

- 11 Black (NCS S 8500-N)
- 24 Beige M1 (NCS S 2005-Y50R)

Lens: PMMA
Body: Aluminum

LED Colour Temperature

Ø 3 cm
Static White
2700 K - 451 lm
3000 K - 471 lm
3500 K - 489 lm
4,3W

Ø 4 cm
Static White
2700 K - 530 lm
3000 K - 554 lm
3500 K - 574 lm
5,2W

Only Ref. 6525, 6529, 6534 and 6538
Tunable White (1800 K - 4000 K)
308 lm - 504 lm 5,5W
CRI>90

Control

Analog: On/ Off; 1-10V; Push (simultaneous line)
Digital: DALI-2 (simultaneous line);
Smart: Casambi (simultaneous line);
Casambi (P2P); ProtoPixel* (P2P)

*ProtoPixel products are compatible with all other DALI-2 products via a designated gateway (please consult us)

Updated detailed spec sheets on vibia.com



Accent Downlight

Accent Spotlight

DOWNLIGHT Ø 3 cm

SPOTLIGHT Ø 3 cm

6500 Narrow
6504 Medium

Ø 3 x 15 cm



6510 Narrow
6514 Medium

Ø 3 x 20 cm



Narrow

Medium

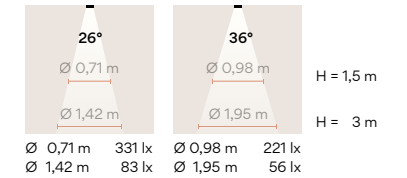

DOWNLIGHT Ø 4 cm

SPOTLIGHT Ø 4 cm

6520 Narrow
6524 Medium
6528 Wide

Ø 4 x 17,5 cm



6530 Narrow
6534 Medium
6538 Wide

Ø 4 x 22,5 cm

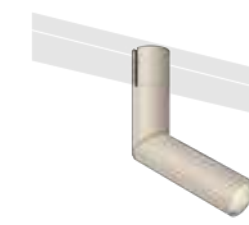

Narrow

Medium

Wide

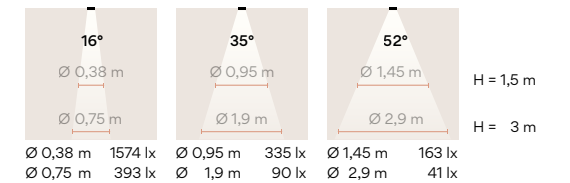

6525 Medium
6529 Wide

Ø 4 x 20 cm

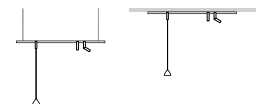



To highlight a particular activity zone or feature, Bind is compatible with a wide accent downlight fixture that provides functional diffuse and accented lighting.

- 11 Black (NCS S 8500-N)
- 24 Beige M1 (NCS S 2005-Y50R)

Lens: PC- Polycarbonate
Body: Aluminum

LED Colour Temperature

Static White
2700 K - 1256 lm
3000 K - 1313 lm
3500 K - 1360 lm
12,4W
Tunable White (1800 K - 4000 K)
Smart (P2P)
571 lm - 895 lm 8,9W
CRI>90

Control

Analog: On/ Off; 1-10V; Push (simultaneous line)
Digital: DALI-2 (simultaneous line)
Smart: Casambi (simultaneous line); Casambi (P2P); ProtoPixel* (P2P)

*ProtoPixel products are compatible with all other DALI-2 products via a designated gateway (please consult us)

Updated detailed spec sheets on vibia.com

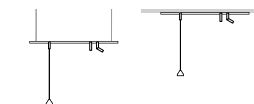

Wide Accent Downlight

6540 Medium
6542 Wide

Ø 18,5 cm

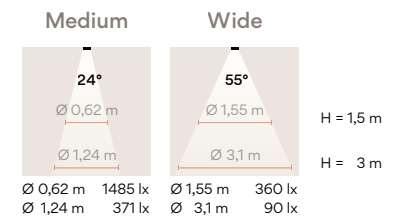

Bind track is compatible with the Skan, Slim, North, Tempo and Tube pendant collections, presenting a range of decorative silhouettes with multiple lighting effects. Single or multiple pendants can be suspended as desired, allowing for the formation of intricate chandeliers created from a compilation of tracks with multiple pendants.

Track adapter: Aluminum

LED Colour Temperature

2700 K; 3000 K; 3500 K
CRI>90

Control

Analog: On/Off; Push; 1-10V (simultaneous line);
Digital: DALI-2 (simultaneous line);
Smart: Casambi (simultaneous line);
Casambi (P2P); ProtoPixel (P2P)

Updated detailed spec sheets on vibia.com

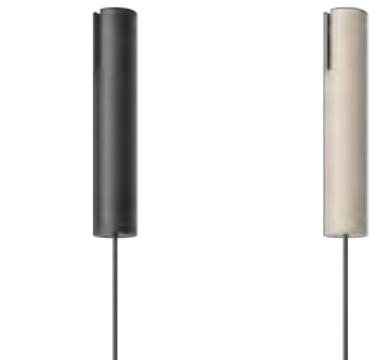

Track adapter

- Black (NCS S 8500-N)
- Beige M1 (NCS S 2005-Y50R)



6560 (Black)
6561 (Beige)

Skan Colours

- 10 White (NCS S 0300-N)
- 11 Black (NCS S 8500-N)
- 24 Beige M1 (NCS S 2500-Y50R)
- 37 Terra Red (NCS S 4040-Y70R)
- 42 Blue M1 (NCS S 5010-B10G)
- 47 Green L1 (NCS S 4005-G80Y)



6570 (Black)
6571 (Beige)

Slim Colours

- 10 White (NCS S 0300-N)
- 11 Black (NCS S 8500-N)
- 24 Beige M1 (NCS S 2500-Y50R)
- 37 Terra Red (NCS S 4040-Y70R)
- 47 Green L1 (NCS S 4005-G80Y)
- 68 Ocre (NCS S 3050-Y30R)



6575 (Black)
6576 (Beige)

North Colours

- 10 White (NCS S 0300-N)
- 11 Black (NCS S 8500-N)
- 24 Beige M1 (NCS S 2500-Y50R)
- 42 Blue M1 (NCS S 5010-B10G)



6590 (Black)
6591 (Beige)

Tube Colours

- 10 White (NCS S 0300-N)
- 15 Grey L2 (NCS S 2500-N)
- 16 Grey M1 (NCS S 4500-N)
- 21 Black Grey (NCS S 7000-N)
- 24 Beige (NCS S 2500-Y50R)
- 37 Terra Red (NCS S 4040-Y70R)



6580 (Black)
6581 (Beige)

Tempo Colours

- 18 Graphite (ADAPTA RF9913WX)
- 37 Terra Red (NCS S 4040-Y70R)
- 58 Cream (RAL 7044)
- 62 Green (NCS S 3010-G20Y)



6583 (Black)
6584 (Beige)

Tempo Colours

- 18 Graphite (ADAPTA RF9913WX)
- 37 Terra Red (NCS S 4040-Y70R)
- 58 Cream (RAL 7044)
- 62 Green (NCS S 3010-G20Y)



6586 (Black)
6587 (Beige)

Tempo Colours

- 18 Graphite (ADAPTA RF9913WX)
- 37 Terra Red (NCS S 4040-Y70R)
- 58 Cream (RAL 7044)
- 62 Green (NCS S 3010-G20Y)

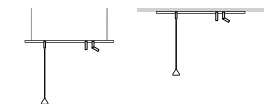

Bind Solo

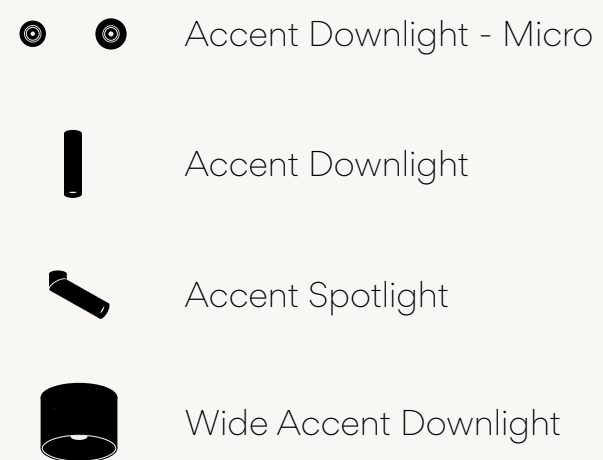

Bind Solo provides a set of tools to play with contrasts, defining functional and transitional areas, as well as hybrid activity zones. The range can be mounted to the ceiling as desired, creating visual hierarchy by directing the gaze towards specific features and combining to form unique compositions overhead.



Dynamic light

Dynamic light allows professionals to play with subtle degrees of intensity and colour temperature to recreate a subtle ambience for every scene within a lighting project

Designing an atmosphere of wellbeing is based on two main axes: **space** and **time**. The axis of time implies the concept of dynamic light.

Atmosphere design is intentional, depending on the **design of different scenes according to the specific use of a space** as it evolves throughout the day. Light is dynamic because ambience also depends **on the time of day** and on the influence of the natural light at every moment.



Throughout the day our circadian rhythms respond primarily to light, which regulates our sense of physical and mental wellbeing

Comfortable environments

Vibia's spot accent, downlight and general lighting luminaires include the option of tunable white. Combining these zenithal tunable white lights with the rest of the diffused and indirect lighting effects of Vibia's portfolio, you can design the perfect scene for every moment and use.

Tunable lighting allows for comprehensive temperature regulation and intensity: colour temperature can be precisely tuned depending on the desired atmosphere for every scene.

Static White

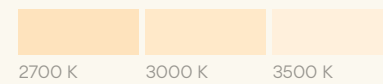

Tunable White

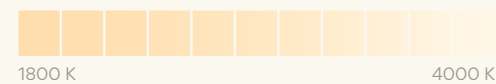

Contact Vibia Support Service at vibia.com for any kind of assistance or recommendation when designing an atmosphere of wellbeing, or if you require support with control system approach.

The simplest and most effective solution for your projects



Accent Downlight - Micro

Bind Solo offers a range of scope apertures to choose from depending on the desired scenography. Thanks to a micro-profile variation, the Accent Downlight offers seamless integration within the surrounding architecture.

- 11 Black (NCS S 8500-N)
- 24 Beige M1 (NCS S 2005-Y50R)

Lens: PMMA
Body: Aluminum

LED Colour Temperature

Ø3 cm

Static White
2700K - 451 lm
3000K - 471 lm
3500K - 489 lm
4,3W

Ø4 cm

Static White
2700 K - 530 lm
3000 K - 554 lm
3500 K - 574 lm
5,2W

Only ref. 6654, 6658
Tunable White (1800 K - 4000 K)
308 lm - 504 lm 5,5W

CRI>90

Control

Analog: On/ Off; Push
Digital: DALI-2*; DALI-2 DT8*
Smart: Casambi

*DALI-2 products are compatible (via a designated gateway) with all ProtoPixel dynamic-light solution products.

Visit vibia.com to group several pieces with just one electrical point

Updated detailed spec sheets on vibia.com



6600 Narrow
6604 Medium

Ø 3 cm

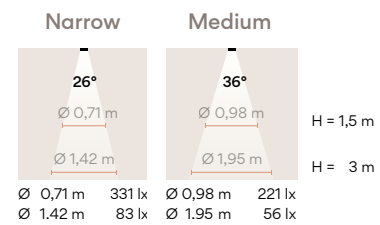

6650 Narrow
6654 Medium
6658 Wide

Ø 4 cm

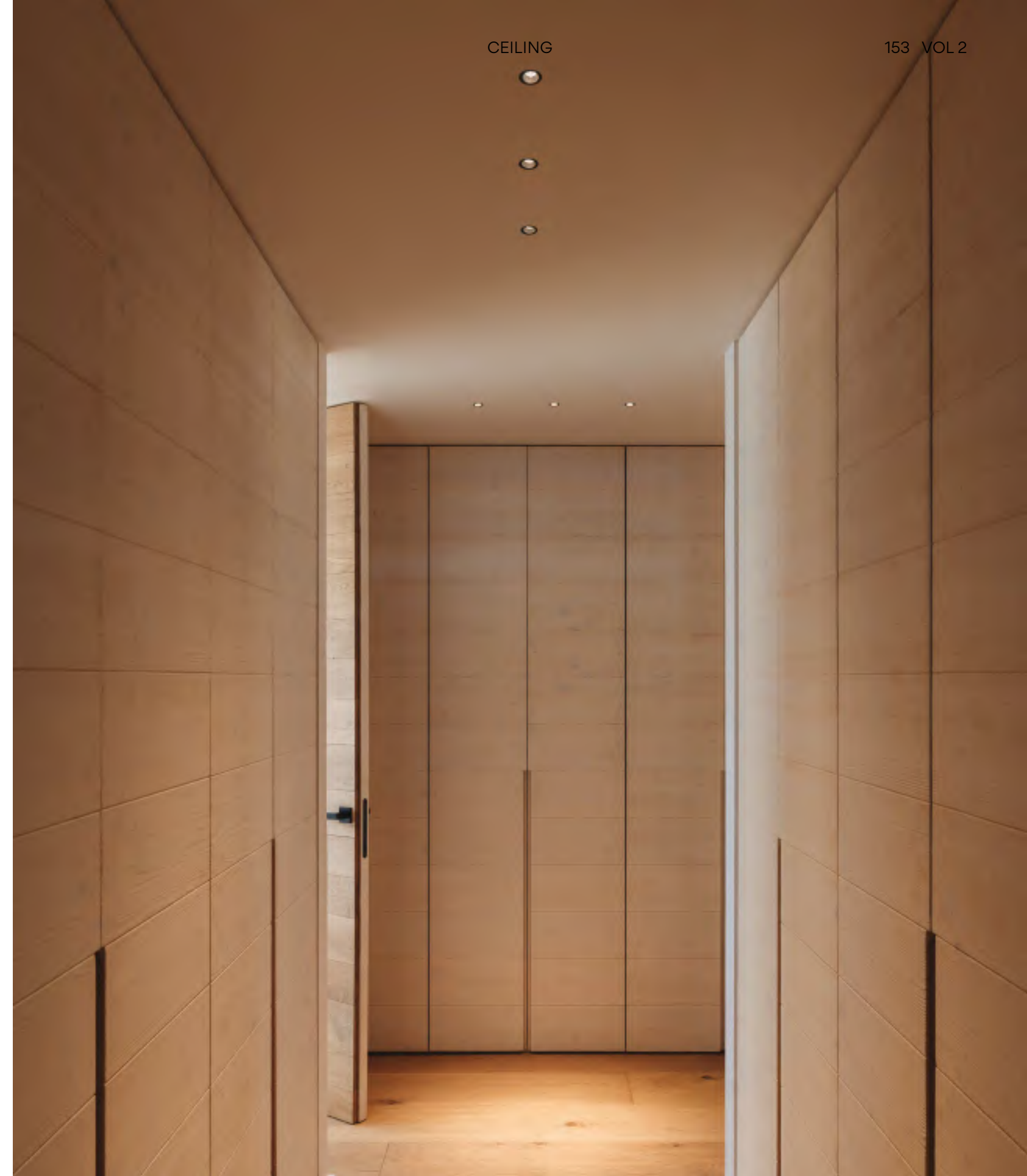
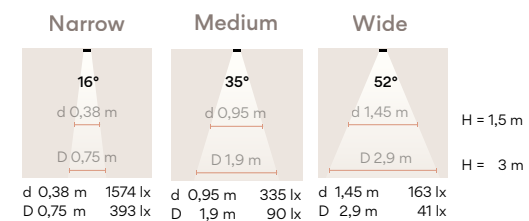



Accent Downlight

For a visually compelling variation, Bind Solo also offers a superficial Accent Downlight in various diameters and lengths. The range of apertures allows for precise modelling of the space using light and shadow.

- 11 Black (NCS S 8500-N)
- 24 Beige M1 (NCS S 2005-Y50R)

Lens: PMMA
Body: Aluminum
Ceiling support: Aluminum

LED Colour Temperature

Ø3 cm

Static White
2700 K - 451 lm
3000 K - 471 lm
3500 K - 489 lm
4,3W

Ø4 cm

Static White
2700 K - 530 lm
3000 K - 554 lm
3500 K - 574 lm
5,2W

Only ref. 6664, 6668, 6684, 6688
Tunable White (1800 K - 4000 K)
308 lm - 504 lm
5,5W

CRI>90

Control

Analog: On/Off; Push
Digital: DALI-2*; DALI-2 DT8*
Smart: Casambi

*DALI-2 products are compatible (via a designated gateway) with all ProtoPixel dynamic-light solution products.

Electrical connection

Remote (Driver included)

Visit vibia.com to group several pieces with just one electrical point

Updated detailed spec sheets on vibia.com



DOWNLIGHT Ø 3 cm

6610 Narrow **6630** Narrow
6614 Medium **6634** Medium

Ø 3 x 4 cm

Ø 3 x 10 cm



Narrow

Medium

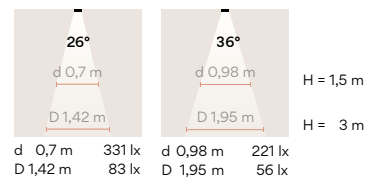

DOWNLIGHT Ø 4 cm

6660 Narrow **6680** Narrow
6664 Medium **6684** Medium
6668 Wide **6688** Wide

Ø 4 x 7 cm

Ø 4 x 10 cm



Narrow

Medium

Wide

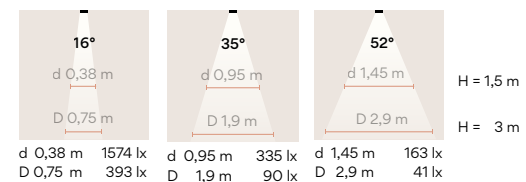

Combining Accent Spotlights with Standard and Wide Accent Downlights, the Bind Solo collection provides comfortable general lighting as well as pointed illumination. Designed to complement Vibia's wider product range, it allows professionals to experiment with light density, combining different lighting typologies to create dynamic and restorative atmospheres.

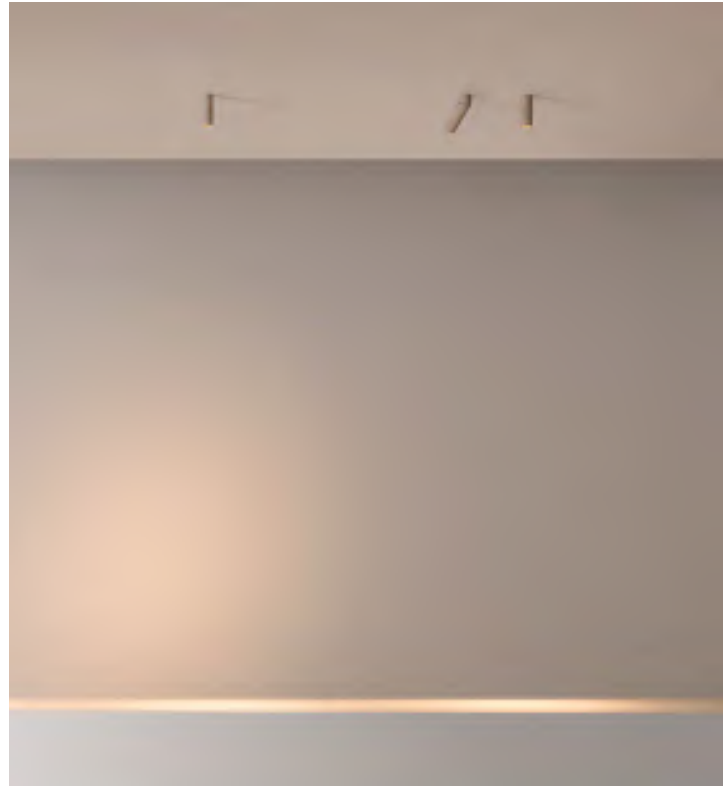
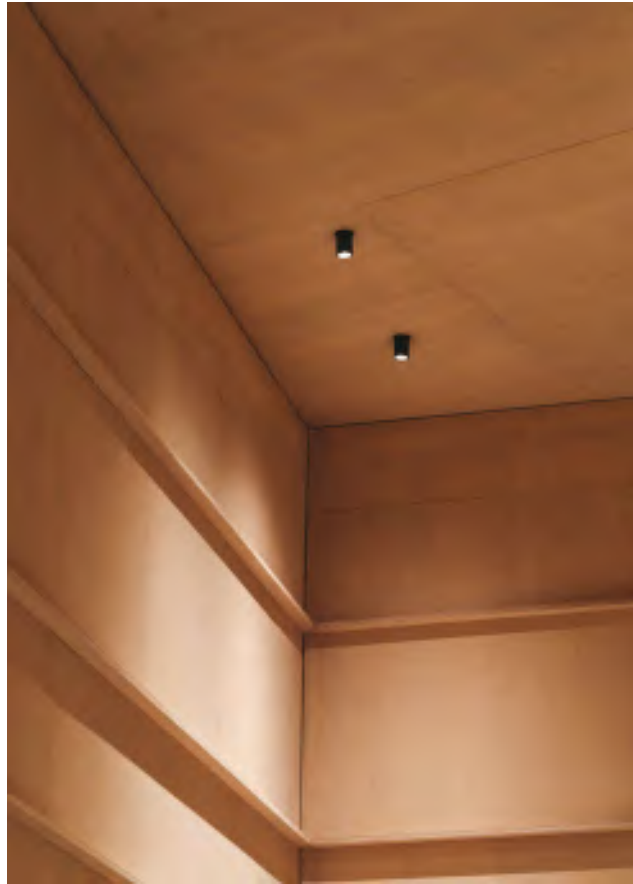

Accent Spotlight

To highlight a particular activity zone or feature, Bind Solo incorporates a series of fixed-angle spots of various lengths.

- 11 Black (NCS S 8500-N)
- 24 Beige M1 (NCS S 2005-Y50R)

Lens: PMMA
 Body: Aluminum
 Ceiling support: Aluminum

LED Colour Temperature

Ø3 cm

Static White
 2700 K - 451 lm
 3000 K - 471 lm
 3500 K - 489 lm
 4,3W

Ø4 cm

Static White
 2700 K - 530 lm
 3000 K - 554 lm
 3500 K - 574 lm
 5,2W

Only ref. 6674, 6678, 6694, 6698
 Tunable White (1800 K - 4000 K)
 308 lm - 504 lm
 5,5W

CRI>90

Control

Analog: On/Off; Push
 Digital: DALI-2*; DALI-2 DT8*
 Smart: Casambi

*DALI-2 products are compatible (via a designated gateway) with all ProtoPixel dynamic-light solution products.

Electrical connection

Remote (Driver included)

Visit vibia.com to group several pieces with just one electrical point

Updated detailed spec sheets on vibia.com

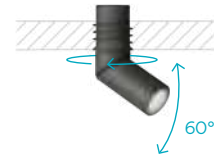

SPOTLIGHT Ø 3 cm

6620 Narrow
 6624 Medium

Ø 3 x 7 cm



6640 Narrow
 6644 Medium

Ø 3 x 11,5 cm



Narrow

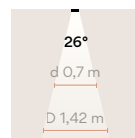

d 0,7 m 331 lx
 D 1,42 m 83 lx

Medium

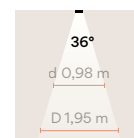

d 0,98 m 221 lx
 D 1,95 m 56 lx

H = 1,5 m

H = 3 m

SPOTLIGHT Ø 4 cm

6670 Narrow
 6674 Medium
 6678 Wide

Ø 4 x 10 cm



6690 Narrow
 6694 Medium
 6698 Wide

Ø 4 x 14 cm



Narrow

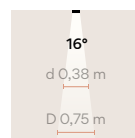

d 0,38 m 1574 lx
 D 0,75 m 393 lx

Medium

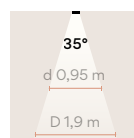

d 0,95 m 335 lx
 D 1,9 m 90 lx

Wide

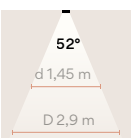

d 1,45 m 163 lx
 D 2,9 m 41 lx

H = 1,5 m

H = 3 m

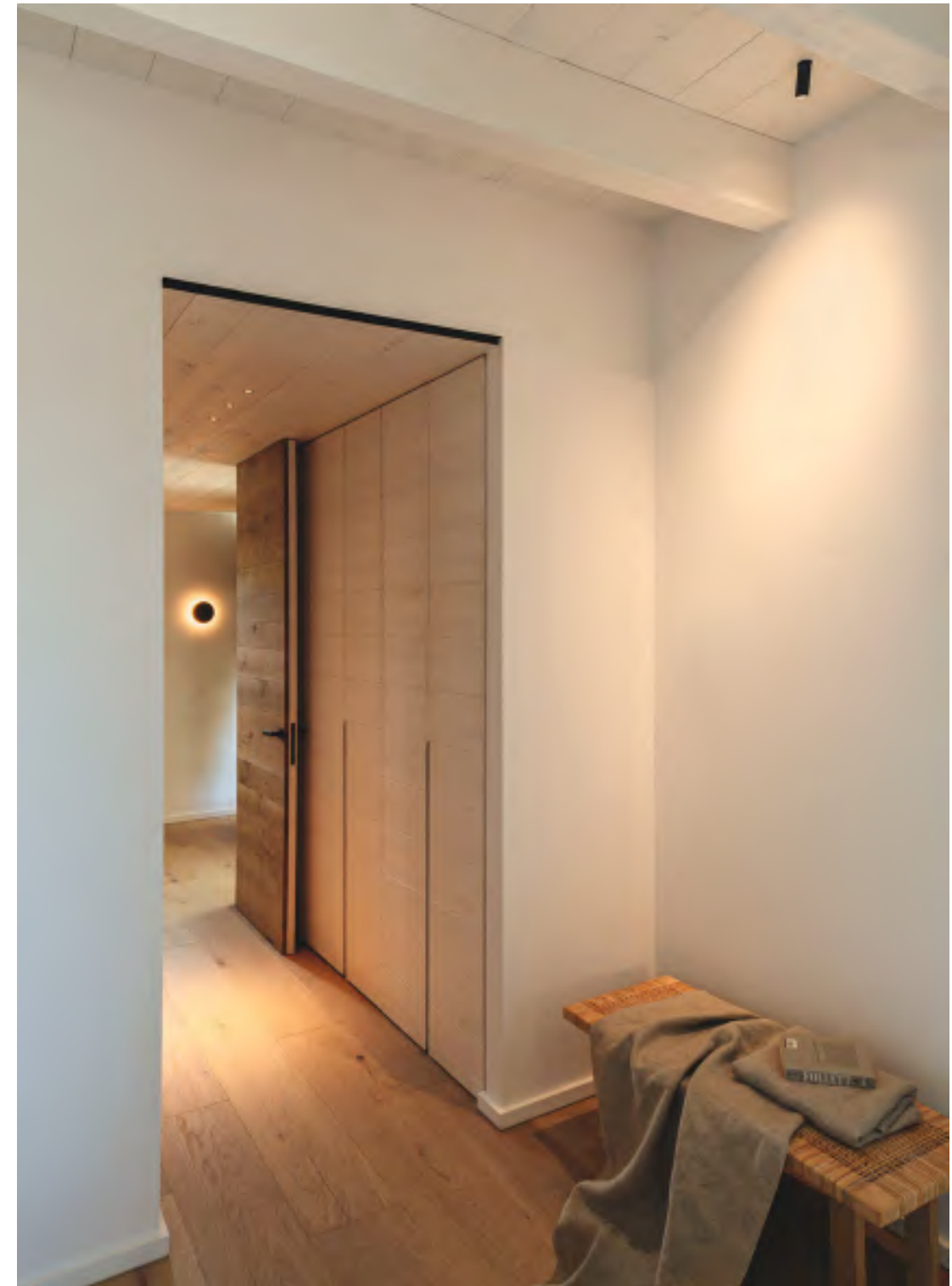



The Bind Solo collection incorporates a range of independent elements that can be fitted directly to the ceiling, including spots, downlights and general lighting fixtures. This combination of functional lighting with decorative pendants means designers can create made-to-measure lighting solutions for moods and uses within the same space.



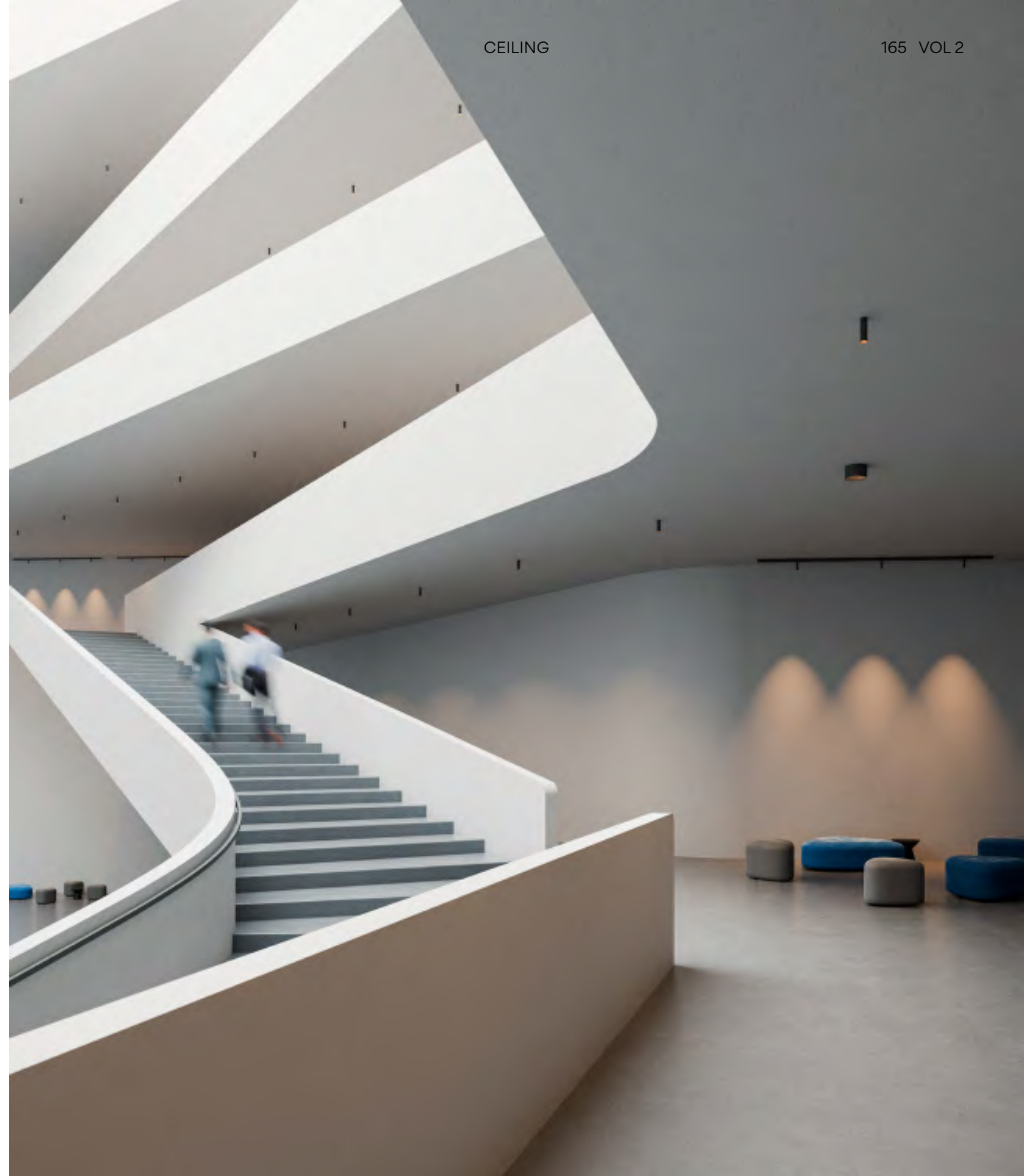

Wide Accent Downlight

For softer contrasts and a more diffuse lighting effect, Bind Solo's Wide Accent Downlight floods the space from above, thanks to a generous diameter and wider gradient of light.

- 11 Black (NCS S 8500-N)
- 24 Beige M1 (NCS S 2005-Y50R)

Lens: PC- Polycarbonate
Body: Aluminum
Ceiling support: Aluminum

LED Colour Temperature

Static White
2700 K - 1256 lm
3000 K - 1313 lm
3500 K - 1360 lm
12,4W

Tunable White (1800 K - 4000 K)
571 lm - 895 lm
8,9W

CRI>90

Control

Analog: Push
Digital: DALI-2*; DALI-2 DT8*
Smart: Casambi

*DALI-2 products are compatible (via a designated gateway) with all ProtoPixel dynamic-light solution products.

Electrical connection

Surface (Driver included)

Updated detailed spec sheets on vibia.com

6700 Medium
6702 Wide

Ø 18,5 cm

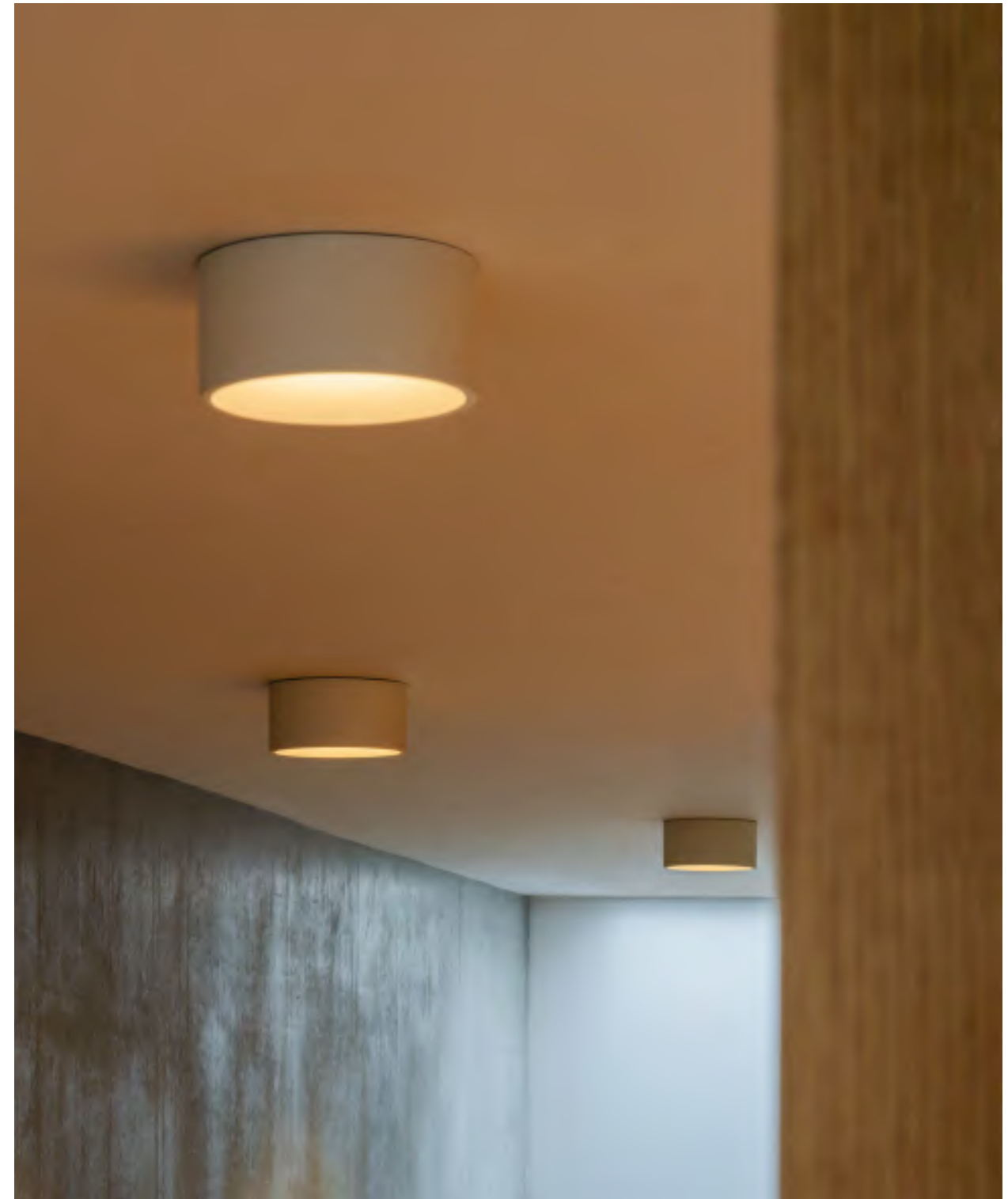
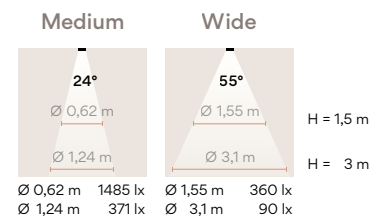

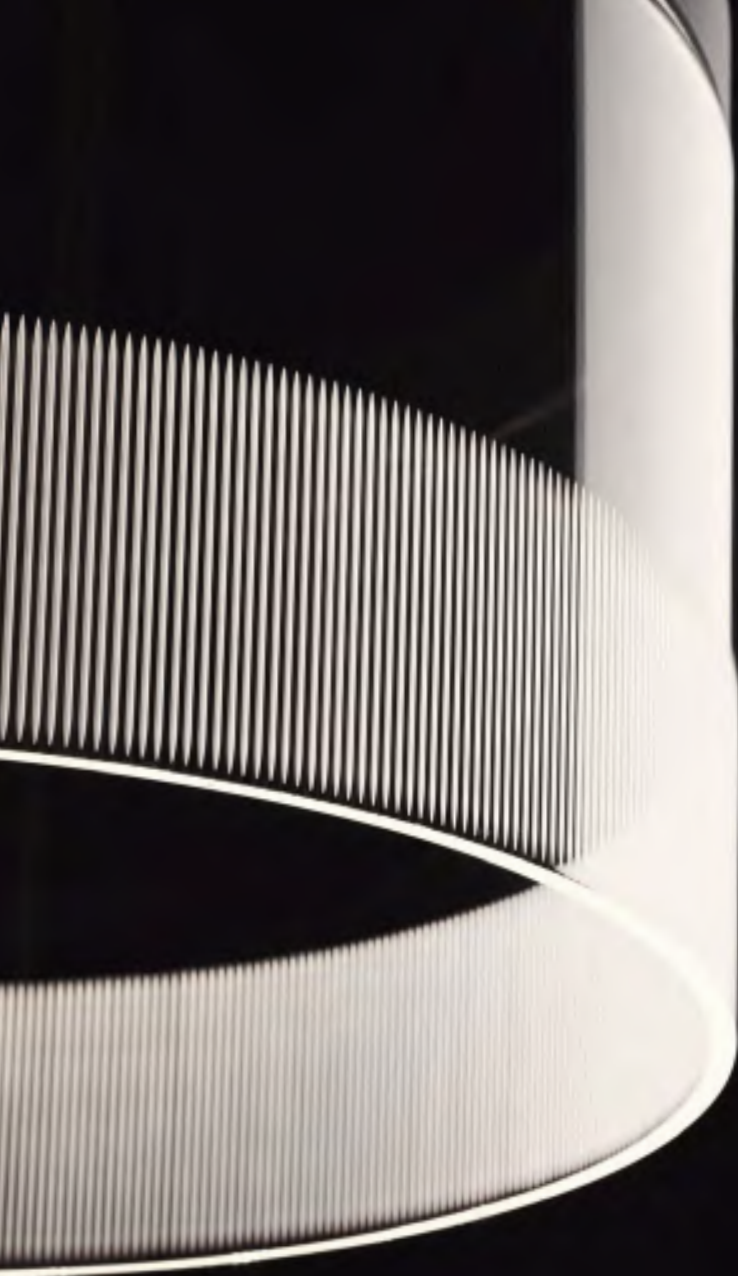

Guise

Design by Diez Office.

Crafted of precision-cut glass and embedded with a row of recessed LEDs, Guise explores the relationship between light and transparency. The light inside the glass appears invisible, while the delicately engraved surface generates a beautiful diffusion.

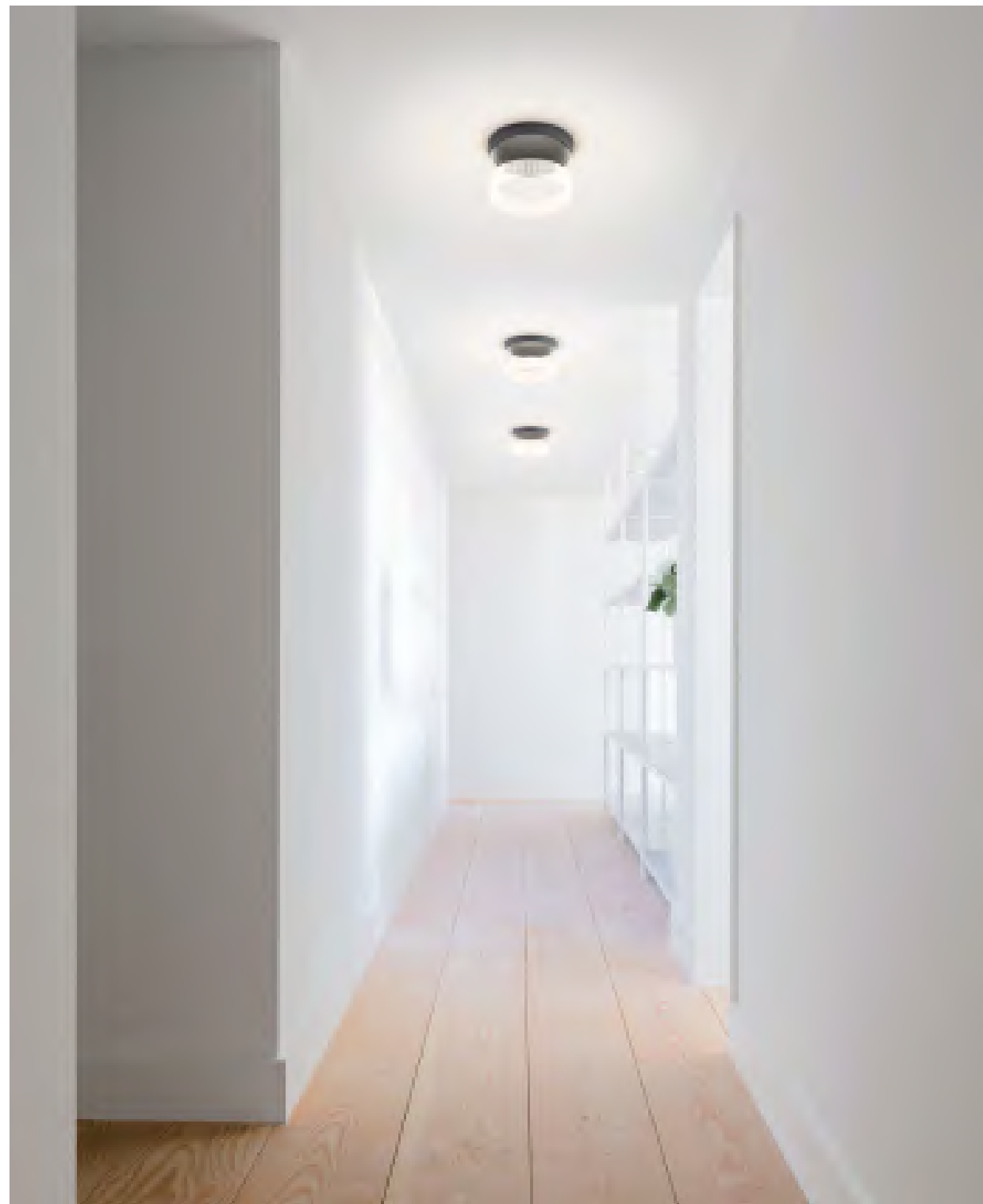



The Guise ceiling light is surface-mounted and available in two sizes. Crafted of precision-cut borosilicate glass, light emanates from the tube while the source remains hidden. When turned on it becomes a luminous hypnotic presence; turned off, the transparent quality of the glass lends an airy sensibility.

● 18 Graphite (ADAPTA RF9913WX)

Diffuser: Borosilicate
Body: Aluminum

LED Colour Temperature
3000 K
CRI>90

Control
Analog: Push; 1-10V
Digital: DALI-2
Smart: Casambi

2292

Ø 25 cm



2298

Ø 40 cm

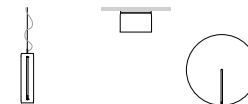
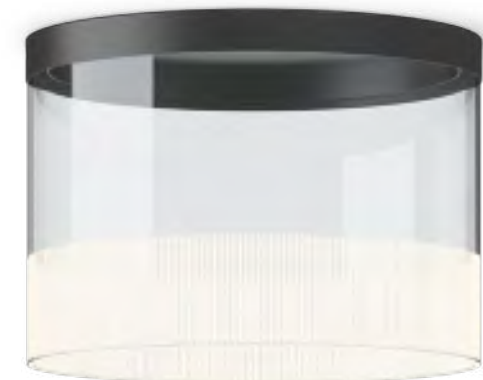

Funnel



A gentle presence with a distinctly sculptural form, Funnel is a study in materiality, light and space.





As its name suggests, light seems to flow freely from the smooth curve of this ceiling fixture. Its sculptural form conceals an LED light source behind the cap. Light is reflected back into the funnel, creating a flood of indirect, ambient illumination. The collection can be mounted individually or as a collection for greater visual impact.

- 10 White (NCS S 0300-N)
 - 36 Soft pink (NCS S 1010-Y50R)
 - 47 Green L1 (NCS S 4005-G80Y)
- Additional finish only for Ref. 2012, 2013
- 51 Gold leaf (Gold)

Shade: Aluminum
 Reflector: Aluminum
 Support: Steel

LED Colour Temperature
 2700 K; 3000 K; 3500 K
 CRI>80; CRI>90

Control
 Analog: On/Off; Push; 1-10V
 Digital: DALI-2
 Smart: Casambi

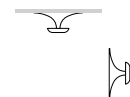

Structural



Design by Arik Levy.

Structural features cubic forms paired with slender metal rods that both join and separate its volumes. Deconstructing the source, it casts light in unexpected places, creating points of light connected in space.





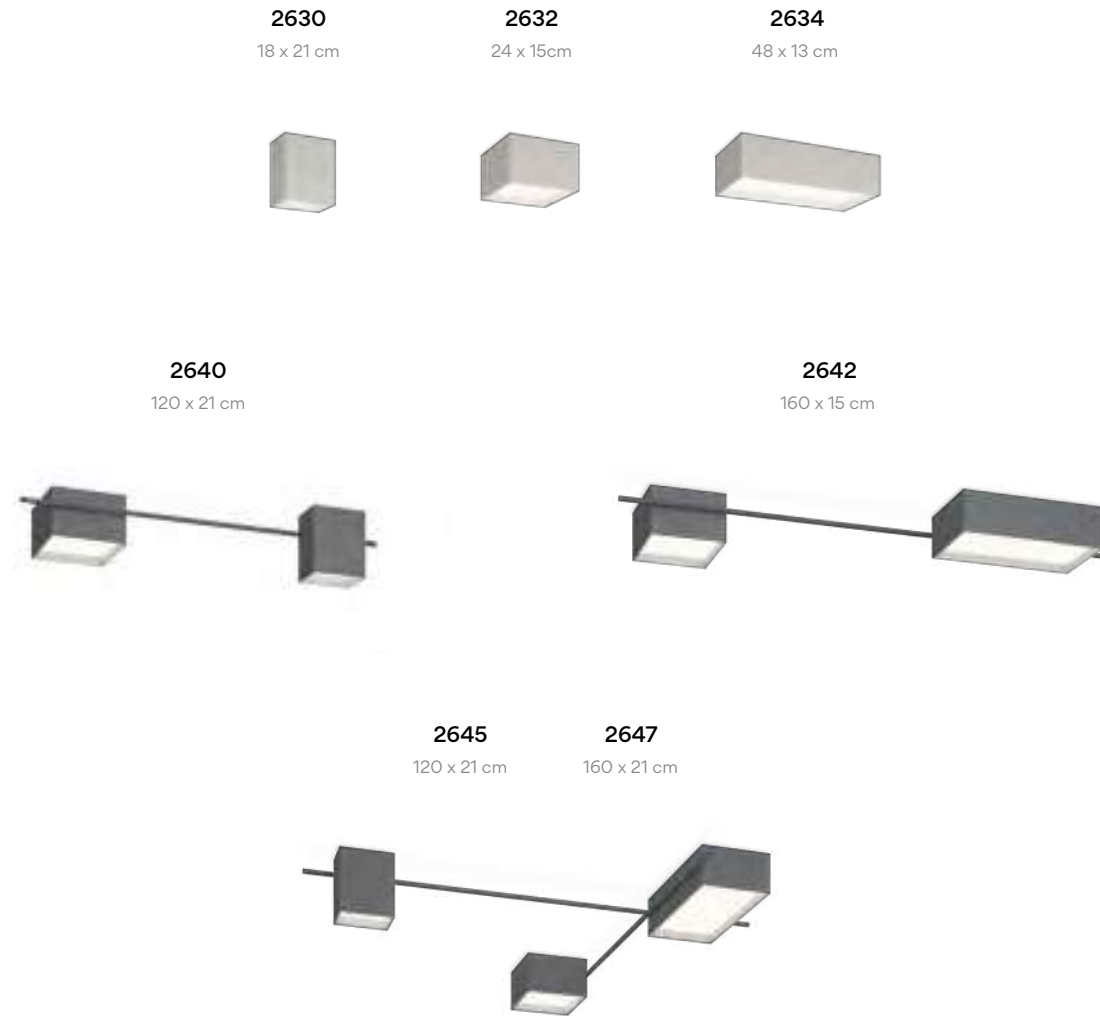

Through the combination of direct and indirect lighting, Structural bathes ceilings with an intense lighting effect. Different cubic volumes meet and expand, its adaptable nature providing flexible solutions while its geometric form maintains a sense of order.

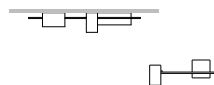

- 15 Grey L2 (NCS S 2500-N)
 - 21 Black Grey (NCS S 7000-N)
- Finish customization
(Available options: Vibia colour palette)
- Diffuser: PC- Polycarbonate
Main body: Aluminum
Structures: Aluminum

LED Colour Temperature
 Static White
 2700 K; 3000 K; 3500 K
 Tunable White (2200 K - 4000 K)
 CRI>90

Control
 Analog: 1-10V
 Digital: DALI-2; DALI-2 DT8
 Smart: Casambi



Vibia's general lighting, spot accent and downlight luminaires include the option of tunable white. Combining these zenithal tunable white lights with the rest of the diffused and indirect lighting effects of Vibia's portfolio, you can design the perfect scene for every moment and use.



Tunable White (2200K – 4000K)
 Tunable white lighting option allows for comprehensive temperature regulation depending on the atmosphere of every scene.

Static White 2700K; 3000K; 3500K
 You can select the static white option that fits best with the desired ambience.

Contact Vibia Support Service at vibia.com for any kind of assistance or recommendation when designing an atmosphere of wellbeing, or if you require support with control system approach.

Spa



Design by Ramos & Bassols.

Spa is the perfect lighting solution for any wellness space. From public dressing rooms, restaurants and spas, to private kitchens, corridors and bathrooms, its graceful simplicity and linear form allow for seamless integration within a variety of humid interiors.

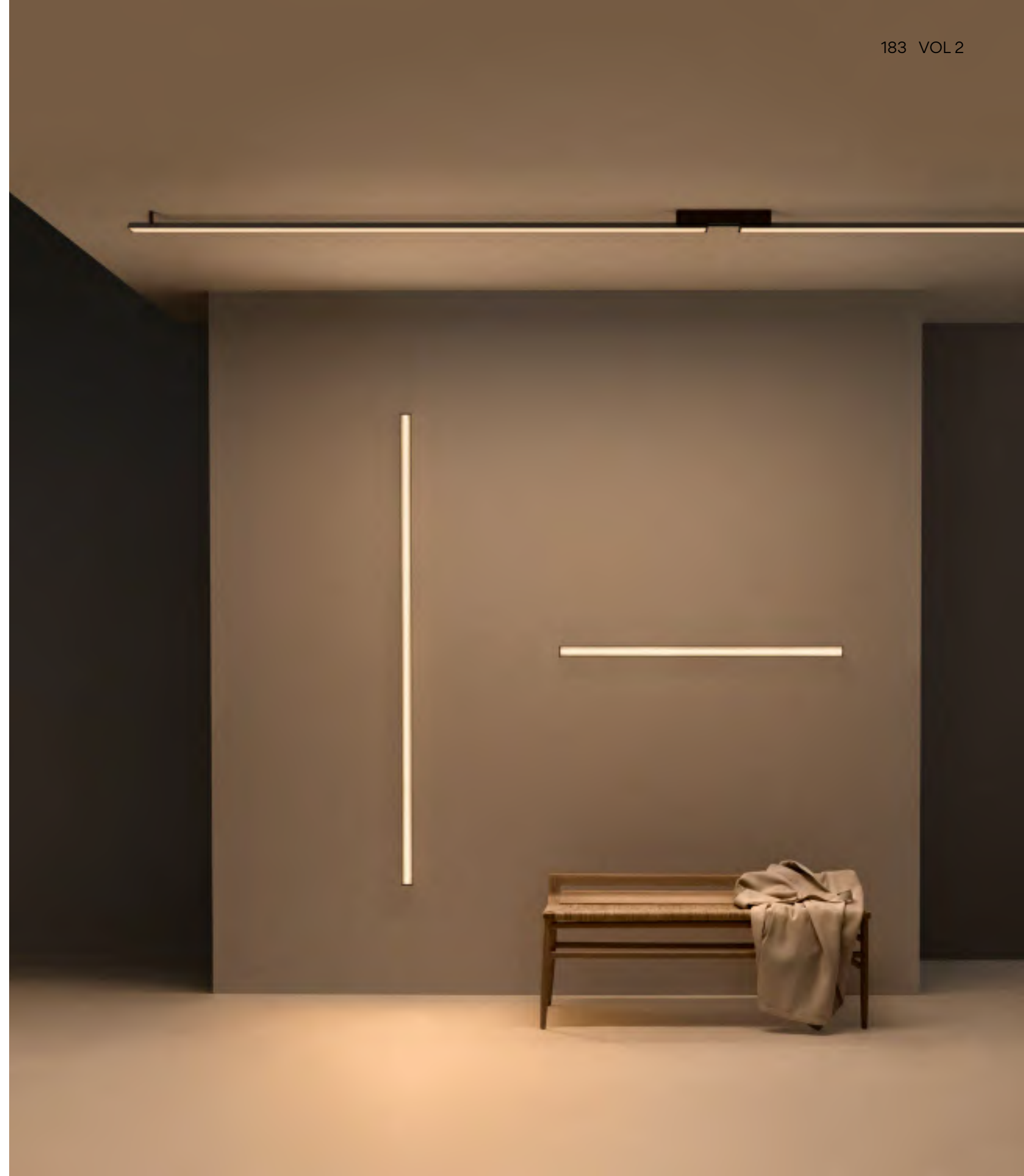

Multiple luminaires can be positioned in a row to illuminate up to six metres of wall or ceiling space from a single point of connection.



WALL & CEILING

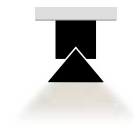

5975

121 x 4,7 x 6,5 cm



5977

201 x 4,7 x 6,5 cm



5979

301 x 4,7 x 6,5 cm



Spa is an adaptable system of linear LEDs that allows for limitless compositional freedom. From intimate corners for personal wellbeing to functional spaces designed for general wellness, Spa's minimalist form and accommodates a range of atmospheres.

- 11 Black (NCS S 8500-N)
- 23 Warm White (NCS S 0502-Y50R)
- 25 Beige D1 (NCS S 4005-Y50R)

Profile and canopy: Aluminum
Diffuser: PMMA



LED Colour Temperature
2700 K; 3500 K
CRI>90

Control
Analog: 1-10V
Digital: DALI-2
Smart: Casambi (Remote)

IP44



WALL & CEILING

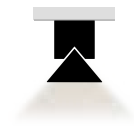

5981

253 x 4,8 x 6,6 cm



5983

413 x 4,8 x 6,6 cm



5985

613 x 4,8 x 6,6 cm



Up



Design by Ramos & Bassols.

Inspired by the neoclassical cornice, Up's geometric form protrudes from the ceiling with a quiet elegance. Its broad flat diffuser and refined rim create the illusion of daylight passing through an opening in the ceiling.



With a depth of merely 7 centimeters, the surface-mounted aluminum fixture adds an understated, yet distinctive design element.

- 18 Graphite (RAL 7016)
- 93 White (RAL 9016)

Finish customization
(Available options: Vibia colour palette)

Diffuser: PC- Polycarbonate
Body: Aluminum
Ceiling support: Steel

LED Colour Temperature

Static White
2700 K
Tunable White (2200K - 4000K)
CRI>90

Control

Analog: Push; 1-10V
Digital: DALI-2; DALI-2 DT8
Smart: Casambi

4440

Ø 50 cm



4442

Ø 77 cm



4460

106 x 106 cm



4452

73 x 121 cm

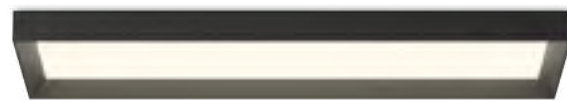

4454

64 x 64 cm

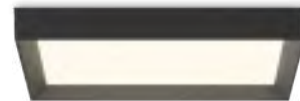

Vibia's general lighting, spot accent and downlight luminaires include the option of tunable white. Combining these zenithal tunable white lights with the rest of the diffused and indirect lighting effects of Vibia's portfolio, you can design the perfect scene for every moment and use.



Tunable White (2200K – 4000K)
Tunable white lighting option allows for comprehensive temperature regulation depending on the atmosphere of every scene.

Static White 2700K

Contact Vibia Support Service at vibia.com for any kind of assistance or recommendation when designing an atmosphere of wellbeing, or if you require support with control system approach.

Puck

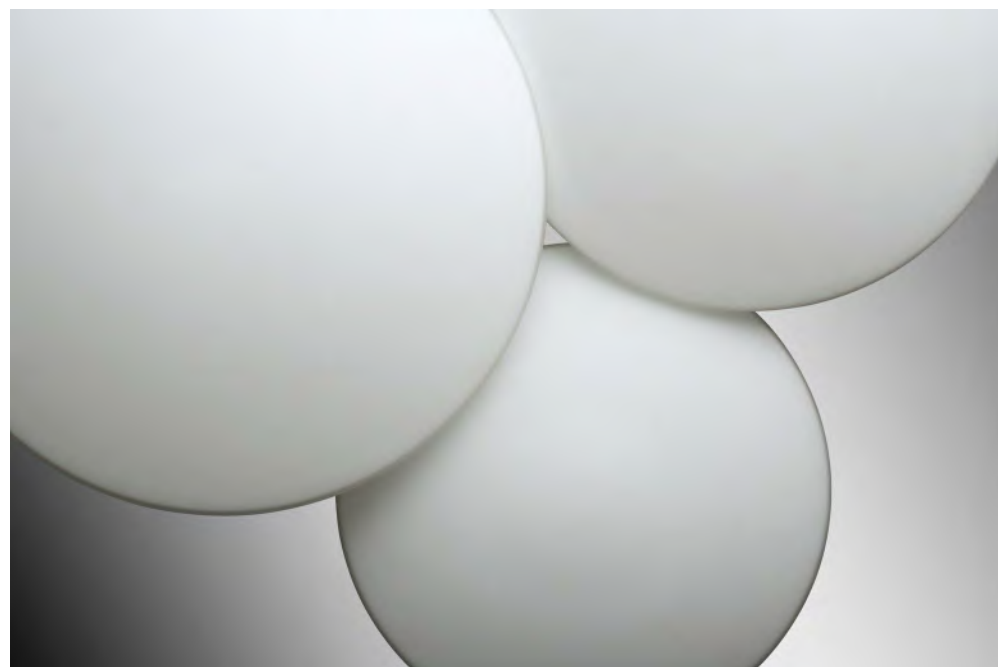

Design by Jordi Vilardell.

Inspired by the iconic circle motif, Puck's simple, spherical forms can be superimposed on top of one another, lending the whole an organic sensibility.





The Puck collection offers users a versatile ceiling light defined by its strong formal expression and warm illumination thanks to its LED light source and blown-glass diffuser. Puck combines a series of models of different compositions, all of which work off a single electrical point connection, using circles as their central leitmotif.

● 03 White (RAL 9016)

Control
Analog: On/ Off

Canopy: Aluminum
Diffuser: Blown-glass

All versions require just one electrical connection.
Surface mounted

LED Colour Temperature

2700 K
CRI>90



5410
24,4 x 6,6 cm



5412
27,2 x 7,7 cm



5430 5432
46,7 x 38 cm



5435 5437
56,8 x 49,2cm

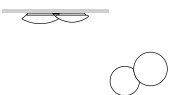

Tube Free



Design by Ichiro Iwasaki.

With the Tube ceiling collection, Ichiro Iwasaki endeavours to create a lighting system capable of forming distinctive expressions by reconfiguring the different constituent parts. By combining three different diameter shades, six colour tones and a rhythm of differing heights, Tube creates a unique landscape of luminaires overhead.





Built-in

6095

Ø 22 cm



6100

Ø 28,5 cm



6105

Ø 41 cm



- 10 White (NCS S 0300-N)
- 15 Grey L2 (NCS S 2500-N)
- 16 Grey M1 (NCS S 4500-N)
- 21 Black Grey (NCS S 7000-N)
- 24 Beige M1 (NCS S 2005-Y50R)
- 37 Terra Red (NCS S 4040-Y70R)

LED Colour Temperature

2700 K; 3000 K; 3500 K
CRI>90

Control

Analog: Push; 1-10V
Digital: DALI-2
Smart: Casambi

Diffuser: PC- Polycarbonate
Led support: Aluminum
Shade: Aluminum
Canopy: Steel

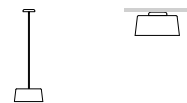

Bigger



Design by La Invisible.

Bigger serves as statement lighting without overbearing the space it occupies. Radiating with profuse light which cascades down from above, its impressive scale and soothing geometry introduce a striking new dimension.





- 23 Beige L1 (NCS S 0502-Y50R)
- 24 Beige M1 (NCS S 2005-Y50R)
- 37 Terra Red (NCS S 4040-Y70R)
- 53 Green M1 (NCS S 6005-G80Y)

Body: Aluminum
Shade: Aluminum
Diffuser: PC- Polycarbonate

LED Colour Temperature

Static White
2700 K; 3500 K
Tunable White (2200K - 4000K)
CRI>90

Control

Analog: Push; 1-10V
Digital: DALI-2; DALI-2 DT8
Smart: Casambi

Updated detailed spec sheets
on vibia.com



Pg 176 VOL 1 Pg 262 VOL 2



Vibia's general lighting, spot accent and downlight luminaires include the option of tunable white. Combining these zenithal tunable white lights with the rest of the diffused and indirect lighting effects of Vibia's portfolio, you can design the perfect scene for every moment and use.

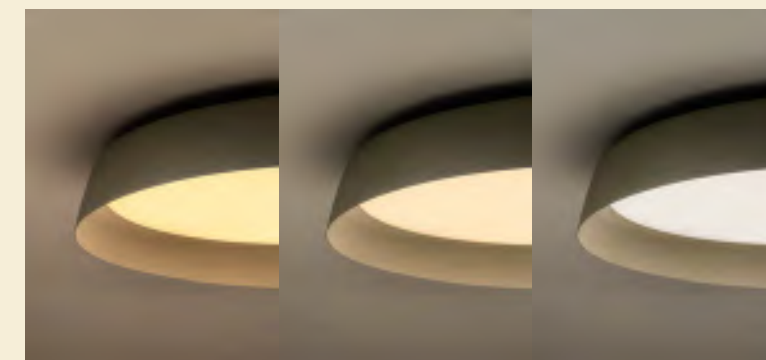

Tunable White (2200K – 4000K)
Tunable white lighting option allows for comprehensive temperature regulation depending on the atmosphere of every scene.

Static White 2700K; 3500K
You can select the static white option that fits best with the desired ambience.

Contact Vibia Support Service at vibia.com for any kind of assistance or recommendation when designing an atmosphere of wellbeing, or if you require support with control system approach.



Wall

Wall

| | | |
|----------------------|--------------------------|-------------------|
| Alpha 316 | North 330 | Set 274 |
| Dots 242 | Offset 348 | Spa 232 |
| Dots Glass 252 | Origami 312 | Sticks 340 |
| Funnel 300 | Palma 256 | Structural 268 |
| Guise 288 | Pin 262 | Suite 304 |
| Halo 336 | Plusminus Solo 216 | Tempo 226 |
| I.Cono 308 | Puck 320 | Top 210 |
| Kontorno 278 | Puck Wall Art 324 | |
| Musa 296 | | |

Top

Design by Ramos & Bassols.

Soft, spherical shapes and a warm luminescence characterize the Top collection. Its glowing epicenter is encircled by a larger ring, framing the light within its pure geometry.







1170
Ø 90 cm



1154
Ø 17 cm



1160
Ø 60 cm



1155
Ø 40 cm

- 10 White (NCS S 0300-N)
- 36 Soft Pink (NCS S 1010-Y50R)
- 40 Blue L1 (NCS S 3010-B)
- 47 Green L1 (NCS S 4005-G80Y)

Body: Aluminum
 Ref. 1170
 Diffuser: Triplex Opal Glass

LED Colour Temperature

2700 K; 3500 K
 CRI>90

Control

Analog: On/ Off; Push; 1-10V
 Digital: DALI-2
 Smart: Casambi

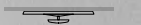

Plusminus Solo

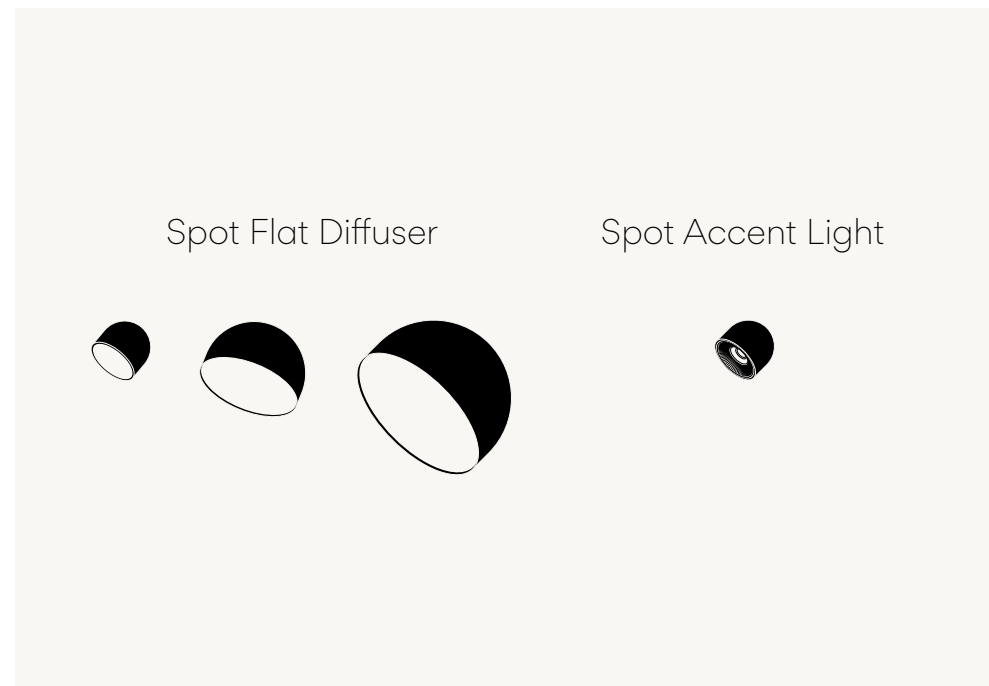

Design by Diez Office.

Plusminus Solo introduces a collection of versatile semi-spherical luminaires that adapt to the surrounding space. Easily adjustable, the Plusminus wall range features semi-spherical directed flat diffusers in different sizes, as well as an accent spotlight for more precise illumination.





To see Plusminus collection
go to page 272 VOL 1



Available in five elegant finishes and mounted as desired, the Plusminus Solo wall range is suitable for functional purposes, such as illuminating a transitional area by bathing a wall with soft light, as well as shaping comfortable scenes through a unique blend of diffuse and accented lighting. Combined with Plusminus Solo floor, table and ceiling luminaires the possibilities are endless.





- 11 Black (NCS S 8500-N)
- 24 Beige M1 (NCS S 2005-Y50R)
- 37 Terra Red (NCS S 4040-Y70R)
- 42 Blue M1 (NCS S 5010-B10G)
- 53 Green M1 (NCS S 6005-G80Y)

Body: Aluminum
Diffuser: PC- Polycarbonate

LED Colour Temperature

Accent
2700 K - 941 lm
3000 K - 987 lm
3500 K - 1022 lm
7,2W

Flat diffuser
LED 2700 K; 3000 K; 3500 K
CRI>90

Control

Analog: On/ Off; Push; 1-10V
Digital: DALI-2
Smart: Casambi

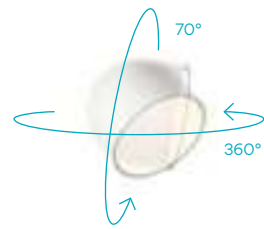

Updated detailed spec sheets on vibia.com

SPOTLIGHT - ACCENT

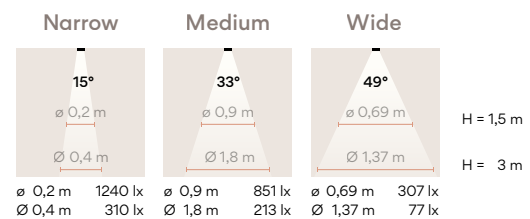

Remote version Built-in

SPOTLIGHT

Accent
6330 Narrow
6331 Medium
6332 Wide
ø 10 cm



Flat diffuser
6333
ø 10 cm



SEMISPHERE

Flat diffuser
6335
ø 20 cm



Flat diffuser
6340
ø 30 cm



Plug version Surface

SPOTLIGHT

Accent
6361 Medium
ø 10 cm



Flat diffuser
6363
ø 10 cm



SEMISPHERE

Flat diffuser
6365
ø 20 cm



Flat diffuser
6370
ø 30 cm

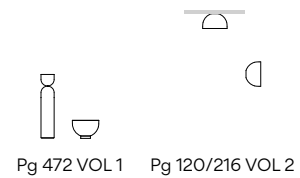

Tempo



Design by Lievore Altherr.

The Tempo collection reclaims our collective memory of light, distilling lighting archetypes into three basic forms: the disc, the diamond and the milk glass oval explore the interplay of opacity, translucence and transparency.





Fusing contemporary style and classic design, the collection is characterised by lean lines and a long adjustable arm that extends out from its vertical base.

The opaline diamond projects a diffused light of a romantic quality, filling a space with its inviting glow. An evolution of the classic bistro globe, the oval diffuser hangs gracefully in the air, its translucency introducing an air of tranquillity. Converting the traditional bulb into a brilliant bubble, the reflector disk embraces an industrial aesthetic. Featuring a flat graphite-coloured plate, light is reflected downwards for a compelling effect.

Ref.
5757, 5759, 5761, 5763,
5765, 5767. Recessed
dimmable driver.

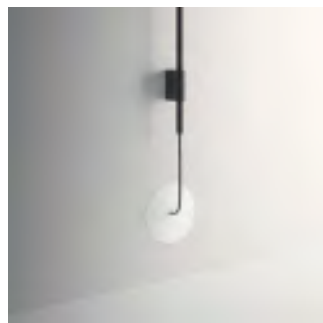

Ref.
5756, 5758, 5760, 5762,
5764, 5766. Push dimmer
on the cable. With plug.

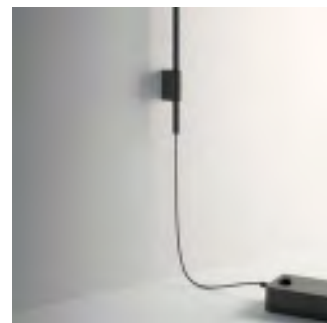



- 18 Graphite (ADAPTA RF 9913 WX)
- 37 Terra Red (NCS S 4040-Y70R)
- 58 Cream (RAL 7044)
- 62 Green (NCS S 3010-G20Y)

Diffuser: Blown-glass
 LED support: Aluminum
 Structures: Steel
 Shade: Aluminum

LED Colour Temperature
 2700 K
 CRI>90

Control
 Analog: Push; 1-10V
 Digital: DALI-2
 Smart: Casambi

5756 5757
 122,5 x 80 cm



5758 5759
 116,5 x 80 cm



5760 5761
 120 x 80 cm



5762 5763
 42,5 x 140 cm



5764 5765
 36,5 x 140 cm



5766 5767
 40 x 140 cm

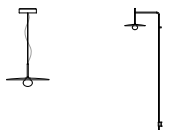

Spa



Design by Ramos & Bassols.

Spa is the perfect lighting solution for any wellness space. From public dressing rooms, restaurants and spas, to private kitchens, corridors and bathrooms, its graceful simplicity and linear form allow for seamless integration within a variety of humid interiors.





The diffuser provides diffuse, glare-free, front lighting, ideal for creating an intimate atmosphere.



Vanity light

Ideal as a bathroom mirror light fixture, Spa can be positioned at an angle to send diffuse, ambient lighting in the desired direction.

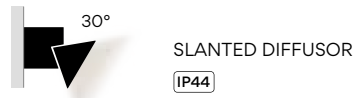

IP44. Spa can be wiped down with a wet cloth for easy maintenance

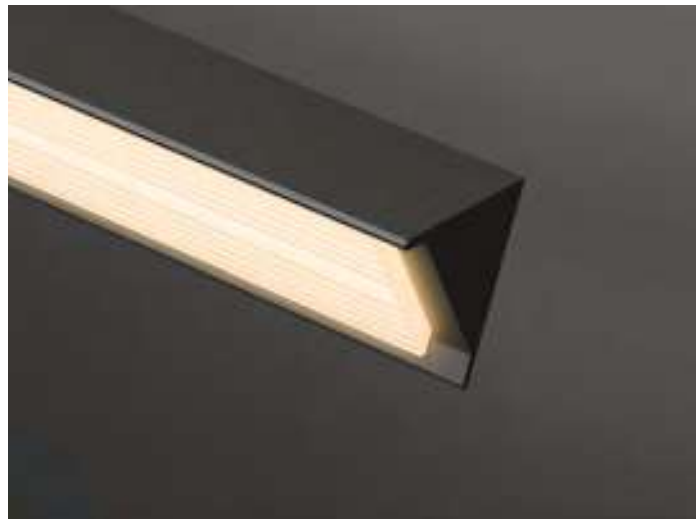

Each luminaire is separated from the wall by a single aluminium support and connects to a simple terminal, invisible from the front, which lends a sense of weightlessness and essentiality to the design.



WALL & CEILING



5975

121 x 4,7 x 6,5 cm



5977

201 x 4,7 x 6,5 cm



5979

301 x 4,7 x 6,5 cm



5981

253 x 4,8 x 6,6 cm



5983

413 x 4,8 x 6,6 cm



5985

613 x 4,8 x 6,6 cm



WALL VANITY LIGHT
(slanted diffusor)



5987

121 x 7,3 x 5,3 cm



5989

201 x 7,3 x 5,3 cm



5991

301 x 7,3 x 5,3 cm



VERTICAL WALL



5995

6,6 x 4,7 x 212 cm



5993

6,6 x 4,7 x 132 cm

- 11 Black (NCS S 8500-N)
- 23 Warm White (NCS S 0502-Y50R)
- 25 Beige D1 (NCS S 4005-Y50R)

Profile and canopy: Aluminum
Diffuser: PMMA

LED Colour Temperature

2700 K; 3500 K
CRI>90

Control

Analog: 1-10V
Digital: DALI-2
Smart: Casambi (Remote)

IP44

Suitable for wet location



Dots



Design by Martín Azúa.

This small scale wall sconce in the form of simple, circular dots delivers high visual impact through a range of lighting effects. Seamlessly connecting a space with an intimate landscape of beams and halos, the collection creates a melody of light like a composition of musical notes in concert with one another.





Its compact shape and coloured lacquer or natural wood finishes mean Dots can be easily integrated into any space.

4662 item with on-off switch on the back plate

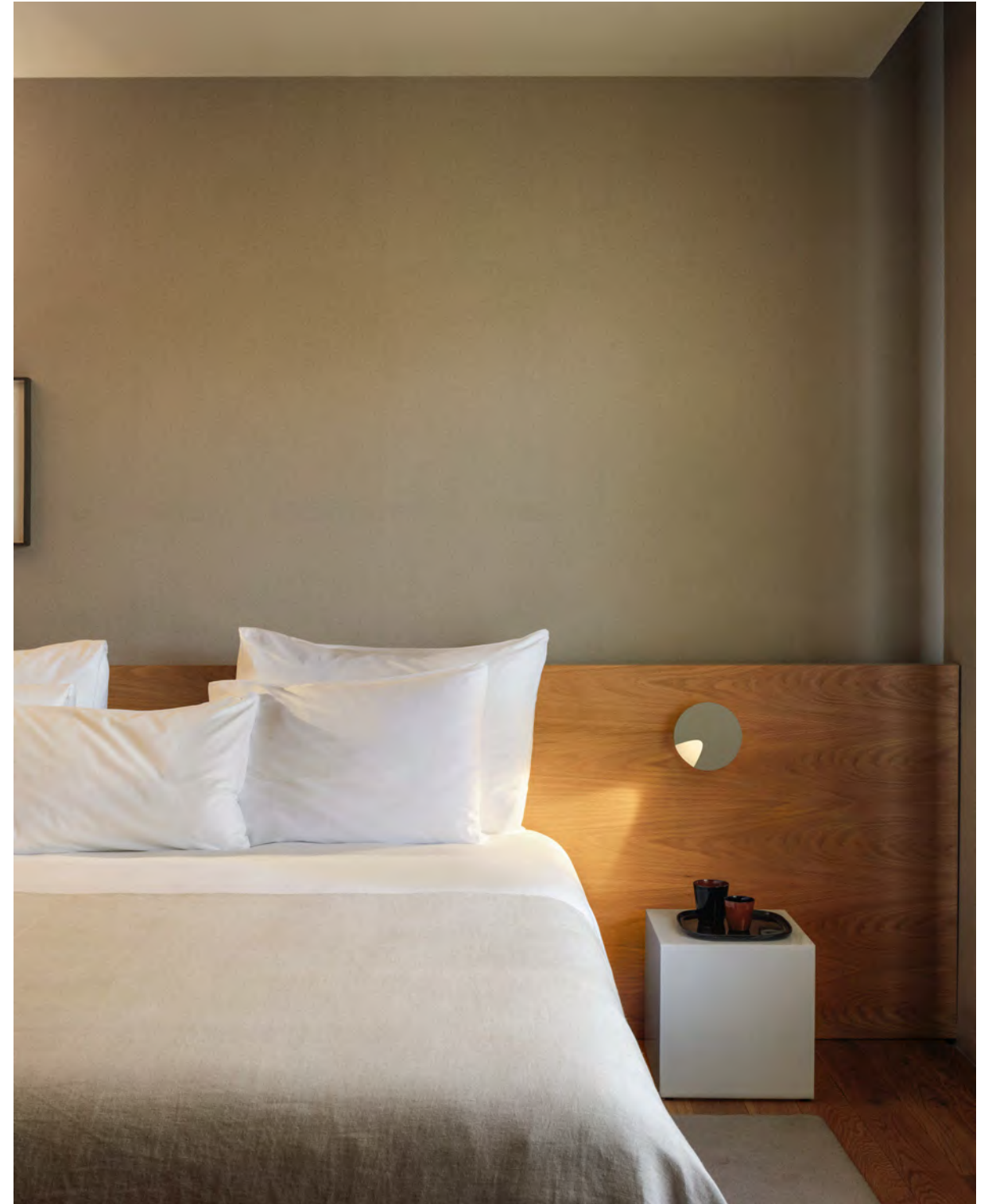





Deployed alone like a sparkling jewel or in combination to create a glowing galaxy, Dots luminaires provide personalised lighting solutions for a range of uses: task lighting, graphic, directional light, and diffuse, ambient illumination.



“Dots is a simple, versatile lighting system that offers many different solutions in one collection. If we forget the idea that wall lamps are boring, we can suddenly start playing with material, colours and lighting effects in group or individually to create comfortable atmospheres”.

Martín Azúa

- 13 Grey L1 (NCS S 1000-N)
- 27 Sand (NCS S 1505-Y50R)
- 37 Terra Red (NCS S 4040-Y70R)
- 47 Green L1 (NCS S 4005-G80Y)
- 82 White oak
- 83 American walnut

Body: ABS or Wood
 Diffuser: PC- Polycarbonate
 Canopy: Aluminum

LED Colour Temperature
 2700 K; 3500 K
 CRI>90

Control
 Analog: On/ Off ; TRIAC; 1-10V
 Digital: DALI-2

360°



Ajustable: 360° turn.
 4662: On-off switch on the back plate.

4660 - 4662
 Ø 17,5 cm



Once installed position is fixed
 and cannot be adjusted.

4665
 Ø 17,5 cm

360°



Ajustable: 360° turn.

4670
 Ø 17,5 cm



4675
 Ø 17,5 cm



Dots Glass



Design by Martín Azúa.

The Dots collection introduces a sleek new diffuser. Sheathed in layers of transparent optical glass, Dots Glass generates a warm, 360-degree glow with a pulsating ambient effect.

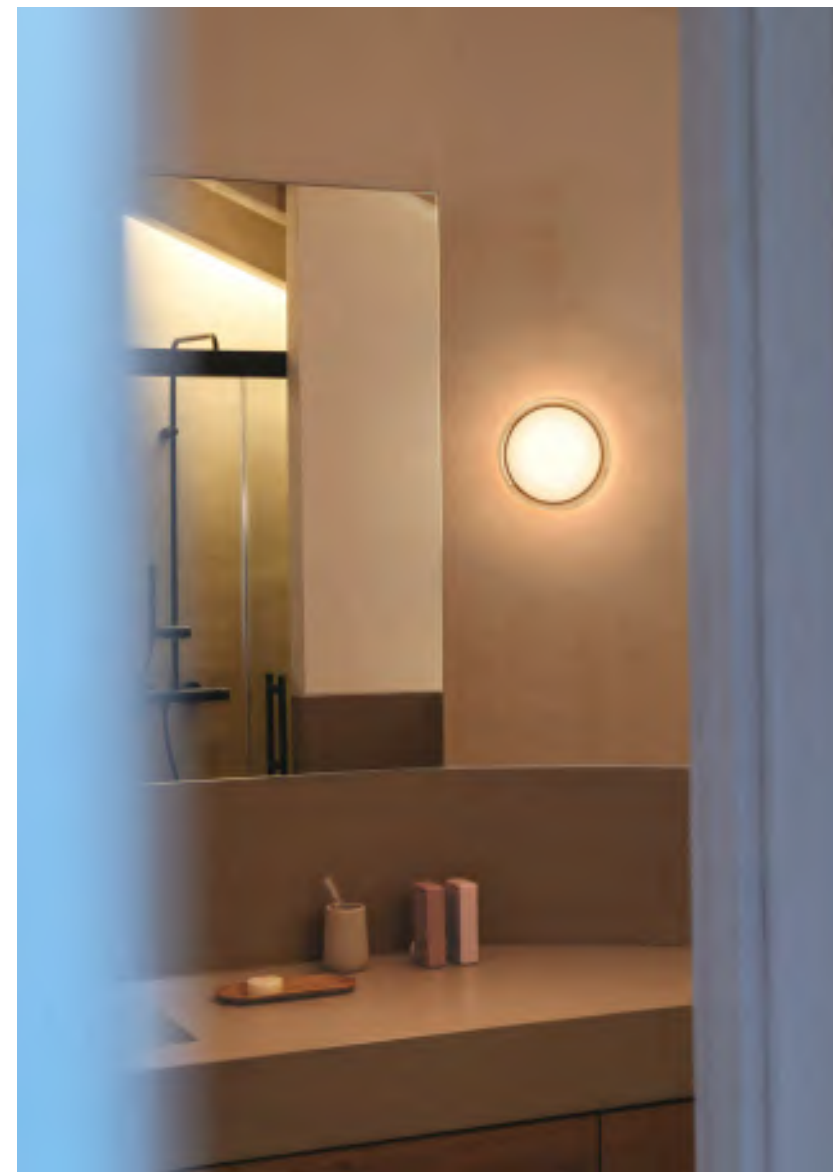



● 10 White (NCS S 0300-N)

Body: Aluminum
Diffuser: Optical Glass

LED Colour Temperature
2700 K; 3500 K
CRI>90

Control
Analog: On/ Off; 1-10V
Digital: DALI-2
Smart: Casambi (Remote)

IP66



4680
Ø 20 cm

Palma



Design by Antoni Arola.

The interior ambience takes on a life of its own with Palma; an unexpected design that accommodates greenery along its axis.





Palma consists of hand blown glass spheres joined together by a contemporary aluminium structure. Available in vertical and horizontal orientations and a choice of one, two or three spheres, the sconces and plantings can be combined in an array of different compositions to span a broad stretch of wall or climb upward towards the ceiling.





3710
22 x 55 x 25 cm

3714
22 x 114 x 26 cm

3716
22 x 114 x 26 cm

3718
22 x 187 x 26 cm

● 18 Graphite (ADAPTA RF 9913 WX)

Diffuser: Blown-glass
Profile: Aluminum
Planter: PMMA

LED Colour Temperature

2700 K
CRI>90

Control

Analog: Push; 1-10V
Digital: DALI-2

3700
55 x 19 x 25 cm

3702
85 x 22 x 25 cm

3704
120 x 22 x 25 cm

3706
195 x 22 x 25 cm



Pin

Design by Ichiro Iwasaki.

A timeless proposal from Japanese designer Ichiro Iwasaki, Pin is both classic and contemporary. Characterised by a graceful stem and subtle, functional expression, it is small in scale but with exceptional lighting efficiency.





As a wall lamp, Pin features a striking interplay of geometric forms. Lean, steel lines extend outward, punctuated by a bold, circular base and aluminum dome shades. Whether displayed individually or in customised combinations, Pin functions as abstract wall art as well as a simple reading light.





1675
Ø 10 cm



1680
25 x 39 cm



1685
30 x 70 x 8 cm



1686
30 x 70 x 8 cm



1690
Ø 10 x 40 x 8 cm



1692
Ø 10 x 70 x 8 cm



1694
70 x 40 x 8 cm

- 11 Black (NCS S 8500-N)
- 23 Warm White (NCS S 0502-Y50R)
- 58 Cream (NCS S 2500-Y20R)
- 62 Green (NCS S 3010-G20Y)

Finish customization
(Available options: Vibia colour palette)

Diffuser: PC- Polycarbonate
Head: Aluminum
Rods: Steel
Base: Zinc Alloy

LED Colour Temperature
2700 K
CRI>90

Control
Analog: On/ Off



Structural



Design by Arik Levy.

Structural features cubic forms paired with slender metal rods that both join and separate its volumes. Deconstructing the source, it casts light in unexpected places, creating points of light connected in space.

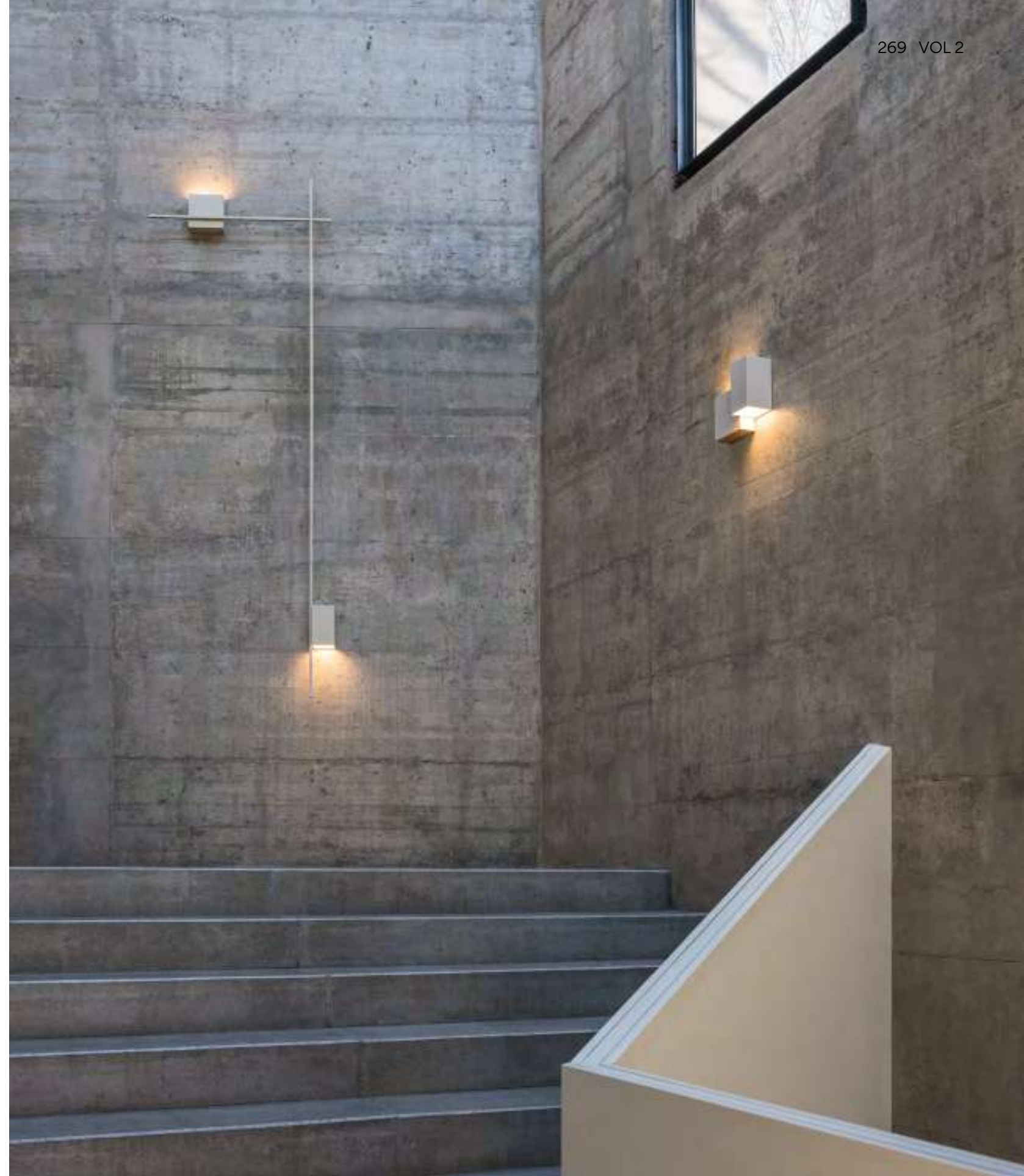





The Structural wall lamp can be combined in various arrangements to integrate with a range of architectural styles and spaces. Marked by lean lines and defined coordinates, it creates glowing sculptural silhouettes. The LED-powered light source is encased in an aluminium box, bathing walls in a bright wash of light without glare.

- 15 Grey L2 (NCS S 2500-N)
- 21 Black Grey D1 (NCS S 7000-N)

Finish customization
(Available options: Vibia colour palette)

Diffuser: PC- Polycarbonate
Main body: Aluminum
Structures: Aluminum

LED Colour Temperature
2700 K; 3000 K; 3500 K
CRI>90

Control
Analog: 1-10V
Digital: DALI-2
Smart: Casambi

2600
16 x 16 cm



2602
26 x 22 cm



2610
120 x 18 x 10 cm

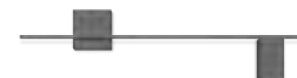

2612
240 x 30 x 10cm



2615
180 x 120 x 10 cm



2617
84 x 240 x 10 cm

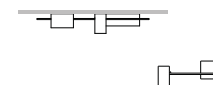

Set

Design by Xuclà.

Set is a new concept of modular wall sconces that composes light as art onto the walls. During the day Set decorates the wall with a pattern of rectangular elements, but once illuminated it creates a surprising play of lights, shadows and volumes.



**7749**

18 x 10 cm

7750

18 x 10 cm

7751

30 x 10 cm

7752

30 x 10 cm

7753

38 x 10 cm

A customised composition of rectangular pieces crafted of an aluminum body and fine borosilicate-glass diffuser, Set both generates and reflects light. It features one fixed component fitted with an LED that casts its light over the other adjustable volumes, each, in turn, emanating elegant rays of light and shadow upwards. The fixture produces an endless array of luminary effects depending on how it's positioned and doubles as dramatic wall art.

- 25 Beige D1 (NCS S 4005-Y50R)
- 93 White (RAL 9003)

Main body: Aluminum
 Diffuser: Borosilicate glass
 Lid: PC- Polycarbonate
 Reflecting bodies: PVC

LED Colour Temperature

2700 K; 3500 K
 CRI>90

Control

Analog: 0-10V



Kontorno



Design by Sebastian Herkner.

Consisting of an elegant linear framework complemented by a cylindrical diffuser or curved reflector, the Kontorno collection envelops the light source it contains, offering diffuse, balanced illumination.





Large-scale glass wall lamp

Pure and refined, Kontorno's cylindrical glass diffuser expresses timeless romanticism with its warm, 360-degree glow.

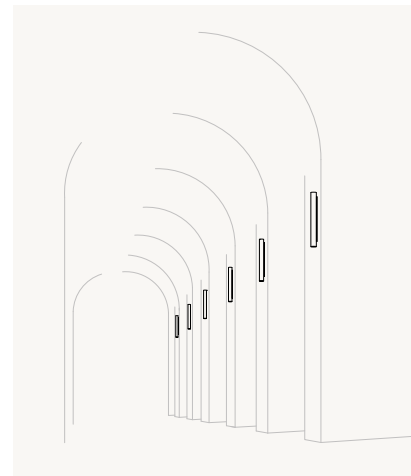

“Kontorno is about simplicity and balance. The light is very poetic and features a frame interacting with different shapes to generate myriad lighting moods and atmospheres.”

Sebastian Herkner.





Glass Shade



6444
19 x 92 cm



6446
19 x 122 cm

● 11 Black (NCS S 8500-N)

Glass shade: Opal triplex
Diffuser: PC- Polycarbonate
Canopy: Aluminum

LED Colour Temperature
2200 K; 2700 K; 3000 K; 3500 K
CRI>90

Control
Analog: Push; 1-10V
Digital: DALI-2
Smart: Casambi

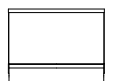



2200 K LED Colour Temperature

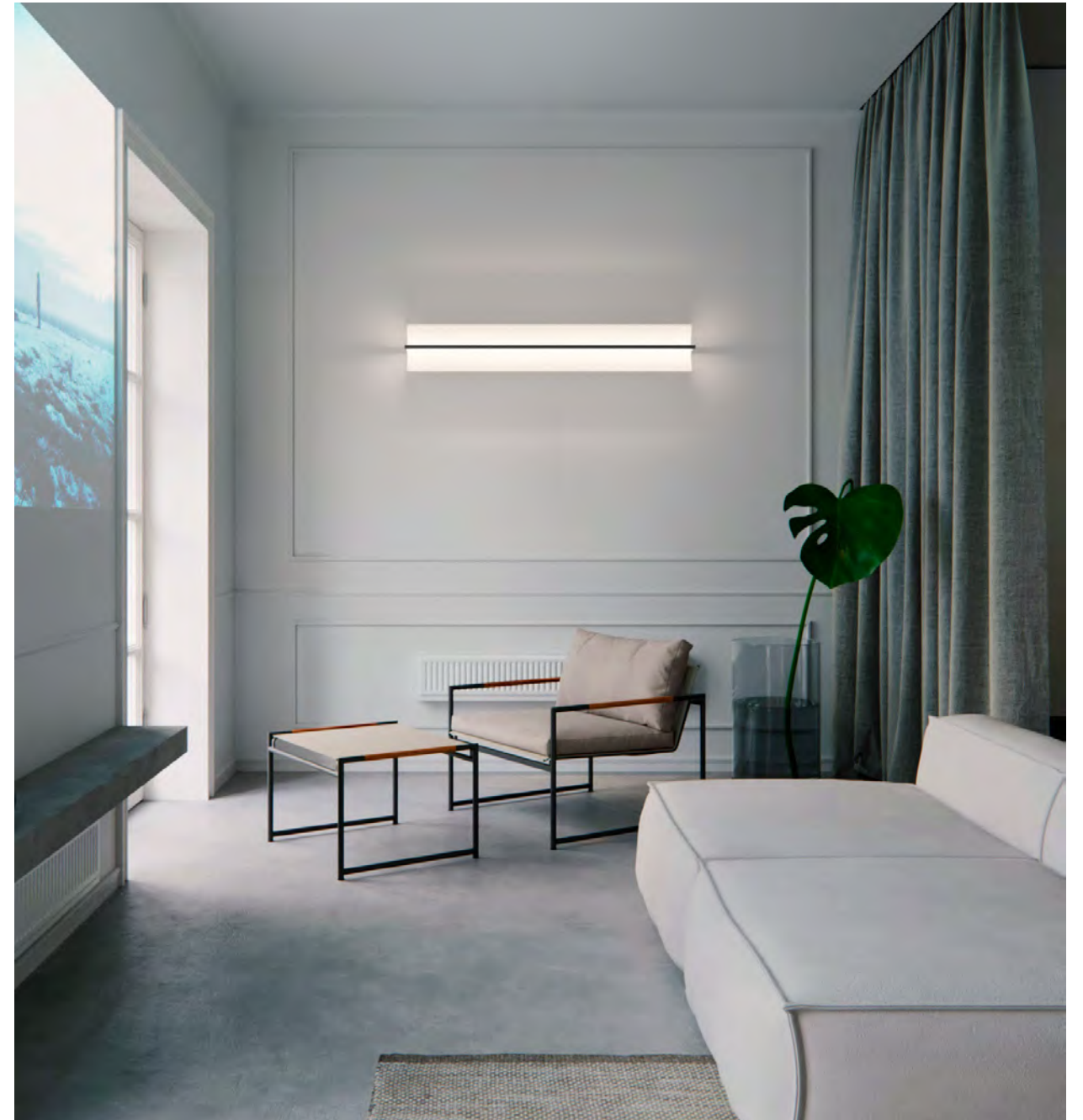
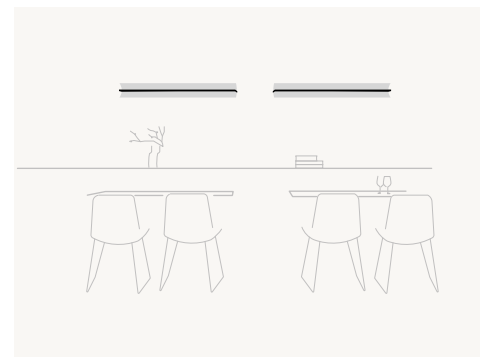

2700 K LED Colour Temperature



Aluminum Shade



6414
20 x 92 cm



6416
20 x 122 cm



6418
20 x 162 cm

● 11 Black (NCS S 8500-N)

Concave shade: Aluminum
Diffuser: PC- Polycarbonate
Structures: Steel
Canopy: Aluminum



LED Colour Temperature
2200 K; 2700 K; 3000 K; 3500 K
CRI>90

Control
Analog: Push; 1-10V
Digital: DALI-2
Smart: Casambi

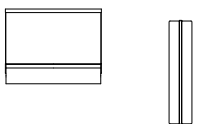

Guise

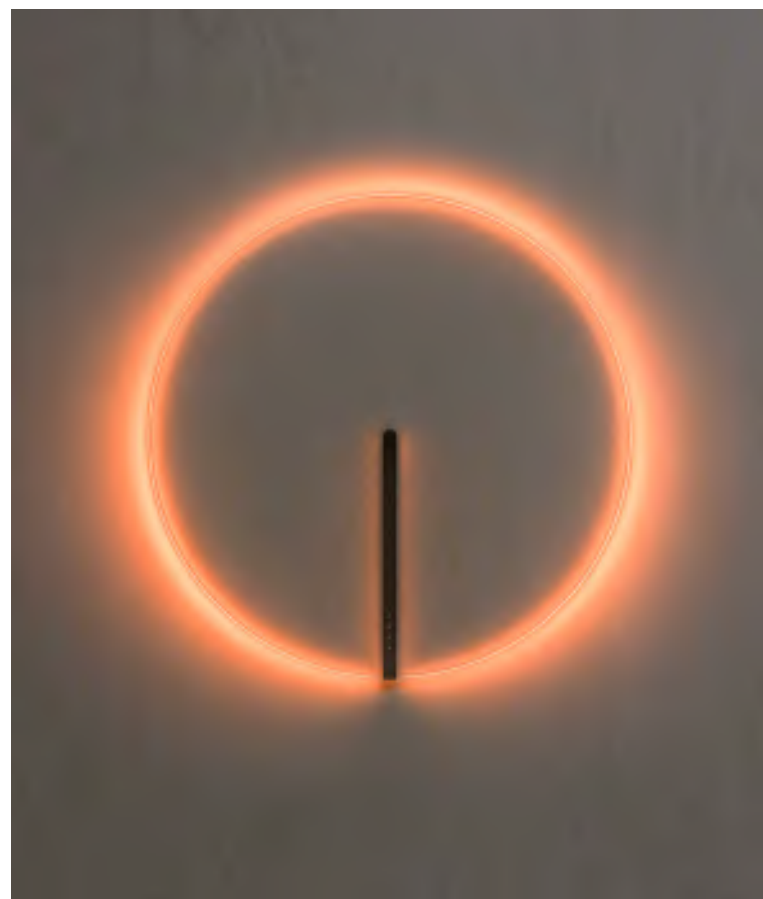

Design by Diez Office.

Crafted of precision-cut glass and embedded with a row of recessed LEDs, Guise explores the relationship between light and transparency. The light inside the glass appears invisible, while the delicately engraved surface generates a beautiful diffusion.



A source of emotion

Colour is a source of emotion it can instantly set a mood, convey a feeling or generate a sense of wellbeing

Vibia's approach to coloured light invites the use of colour and gradients to create and experience different atmospheres, making them as natural and subtle as possible. Natural light is never mono-tonal. Gradients come in infinite colours.



Vibia Chromatica colours of light

Static White

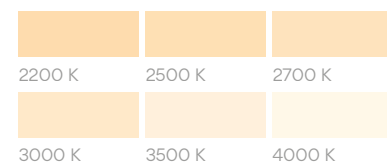

You can select any desired light -white, colour mood or gradient- and intensity manually from the analogic product interface. You can also integrate your selection into the control system for specific scene design and activate it using the Vibia App

Colour Moods

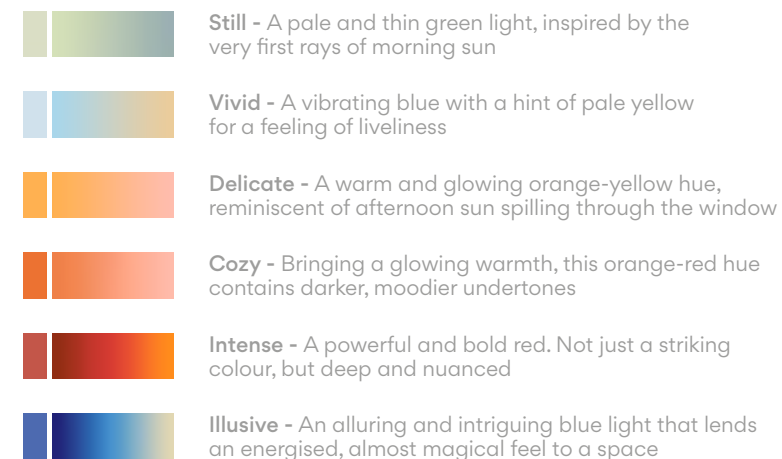

Contact Vibia Support Service at vibia.com for any kind of assistance or recommendation when designing an atmosphere of wellbeing, or if you require support with control system approach.

Cozy colour mood

Bringing warmth and glow, this hue also contains darker, moodier undertones. A deep, burned red tone in the solid colour, while a colder grey-blue tone merges with the red in the gradient.

SURFACE

2260

Ø 54 cm



SURFACE

2262

Ø 92 cm



REMOTE

2263

Ø 92 cm



The Guise wall sconce consists of a glass disk emitting a perimeter glow from a hidden LED light source. When switched on it generates a halo of diffuse light like a solar eclipse; when switched off, the transparent glass and hidden LEDs seem to disappear, hence its enigmatic name.

● 18 Graphite (ADAPTA RF9913WX)

Diffuser: Borosilicate
LED support: Aluminum

LED Colour Temperature

Ref. 2260, 2262

Static White
3000 K

Ref. 2263
Infinite Colour (RGB + TW)

CRI>90

Control

Ref. 2260, 2262

Analog: Optical sensor on the LED support

Ref. 2263

Smart: ProtoPixel* (also with push buttons)



You can select any desired light -white, colour mood or gradient- and intensity manually from the analogic product interface.

*ProtoPixel products are compatible with all other DALI-2 products via a designated gateway (please consult us)

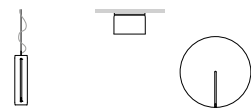

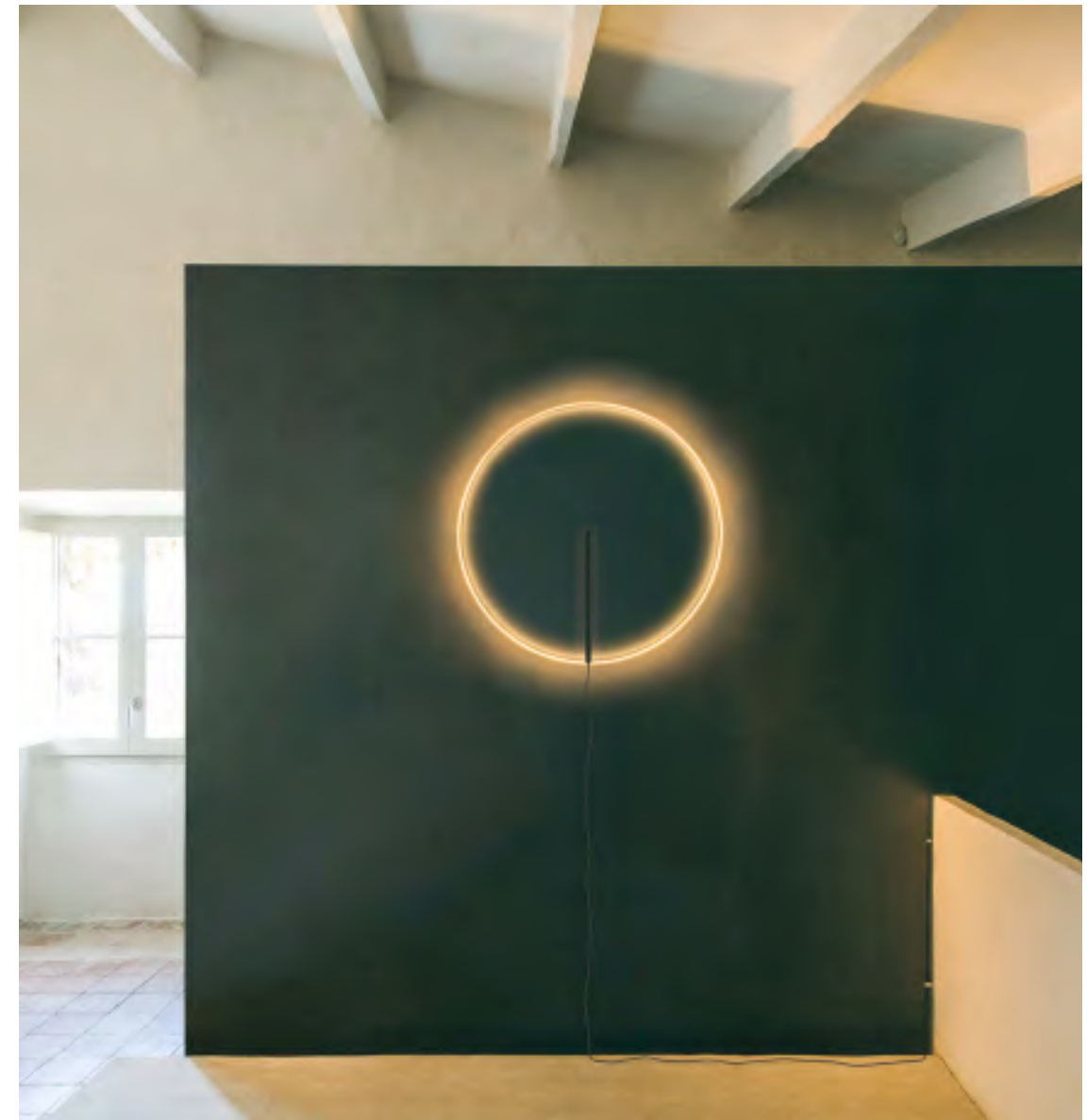

Musa

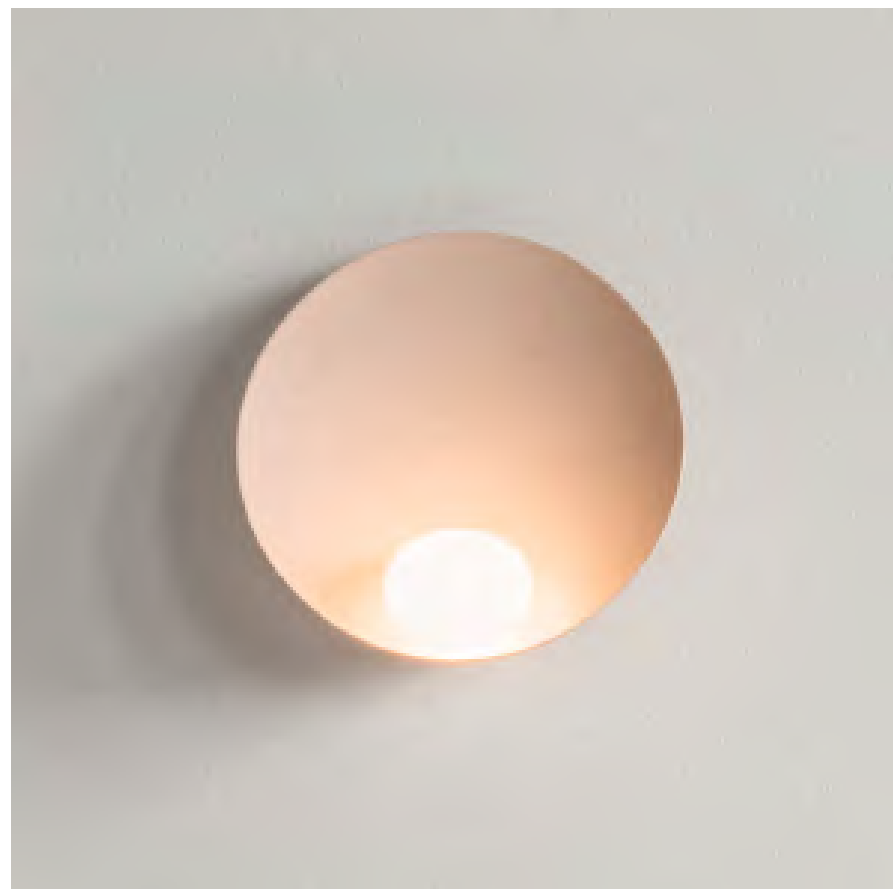

Design by Note Design Studio.

A poetic expression of light, inspired by nature. Cradled by the soft curve of Musa's bowl-shaped diffuser, light is both contained and reflected in its silky veneer.

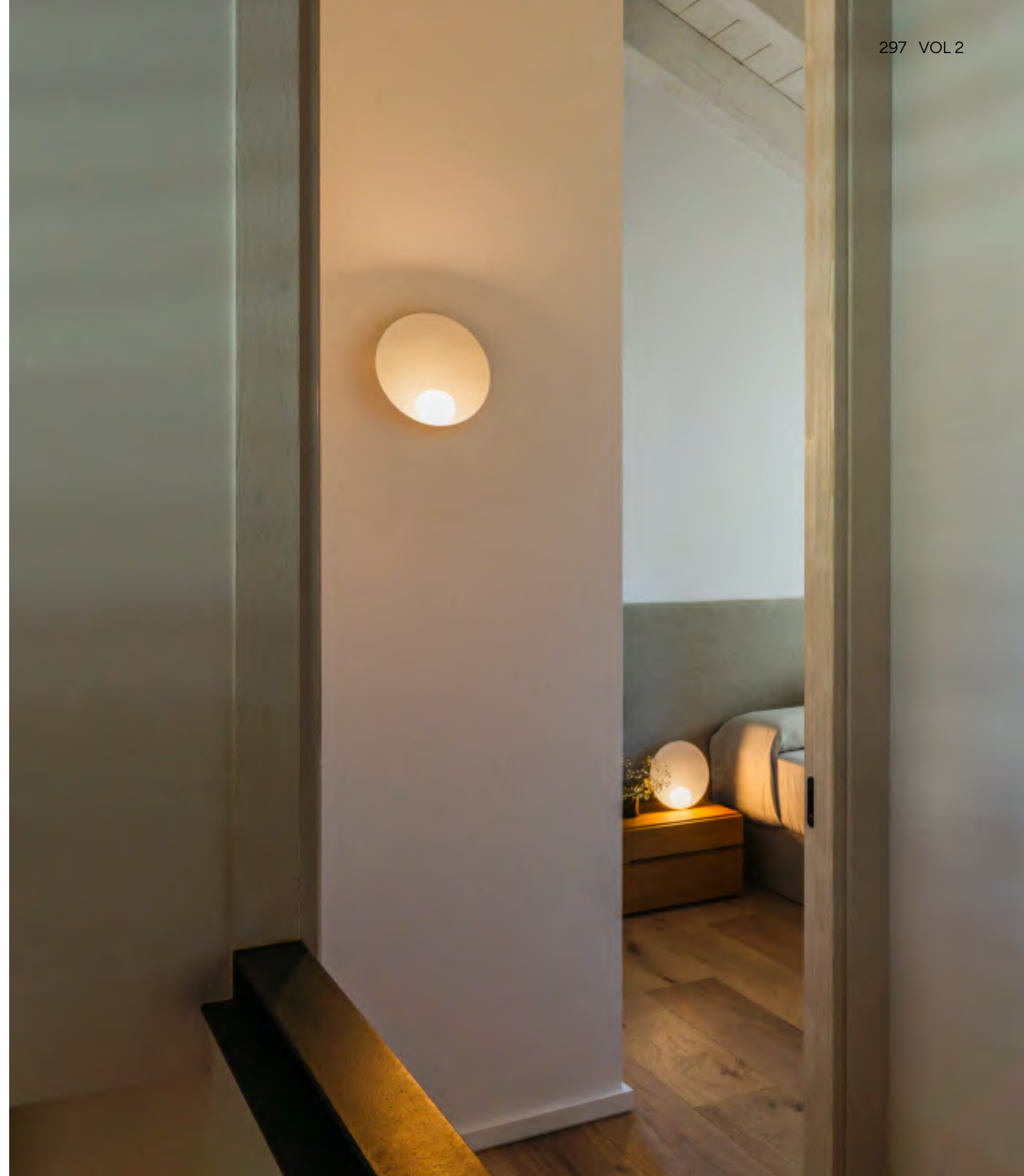



7415

Ø 26 x 10 cm

Musa recalls the organic form of an oyster and pearl. A small, dimmable diffuser nestles at its base, casting a soft glow that spreads across the larger sphere that contains and diffuses it.

- 23 Warm White (NCS S 0502-Y50R)
- 24 Beige M1 (NCS S 2005-Y50R)
- 36 Soft Pink (NCS S 1010-Y50R)

Finish customization
(Available options: Vibia colour palette)

Diffuser: Blown glass
Body: Aluminum

LED Colour Temperature
2700 K
CRI>90

Control
Analog: 1-10V



Funnel



A warm lighting presence with a distinctly sculptural form, Funnel is a study in materiality, light and space.



2012

Ø 22 cm



2013

Ø 35 cm

A fluid design defines this aluminum fixture, a streamlined, funnel-shaped base that flows into a protruding cap. The smooth, sculptural curves conceal a LED light source behind the tip, reflecting light back on the funnel form and creating a flood of indirect, ambient lighting. It can be displayed individually or in a row for greater impact.

- 10 White (NCS S 0300-N)
- 36 Soft pink (NCS S 1010-Y50R)
- 47 Green L1 (NCS S 4005-G80Y)
- 51 Gold leaf (Gold)

Shade: Aluminum
Reflector: Aluminum
Support: Steel

LED Colour Temperature
2700 K; 3000 K; 3500 K
CRI>80; CRI>90

Control
Analog: On/ Off; Push; 1-10V
Digital: DALI-2

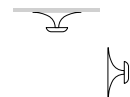
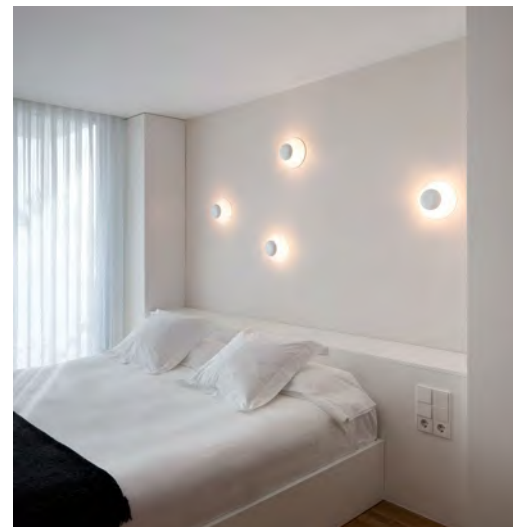

Suite

Design by Jordi Vilardell & Meritxell Vidal.

The Suite wall light doubles up as a convenient storage facility. Depending on the desired effect, the user can choose from a range of different models: a simple shelf, a shelf with a reading lamp, a shelf featuring a luminous object, or an ambient wall sconce. The shelves incorporate an invisible LED tucked underneath, offering an ambient bedside glow.





6046
32 x 29 x 16 cm



6041
32 x 14 x 16 cm



6040
32 x 14 x 16 cm



6045
32 x 29 x 16 cm

- 14 Chocolate (RAL 8019)
- 23 Warm White (NCS S 0502-Y50R)

Finish customization
(Available options: Vibia colour palette)

Diffuser: PC- Polycarbonate / Blown-glass
Shelf: Aluminum
Lid: Steel

LED Colour Temperature
2700 K; 3500 K
CRI>90

Control
Analog: On/ Off

6050
12 x 12 x 10 cm

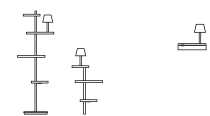
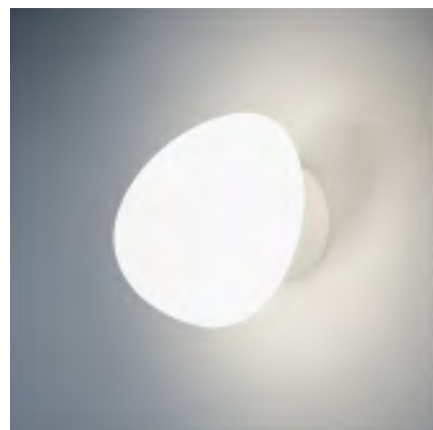

I.Cono



Design by Lievore, Altherr, Molina.

Distinguished by its signature visor-shaped shade, I.Cono presents a poised, Scandinavian presence. The visual purity of its angular shade is matched by a sleek base and complemented by a range of elegant finishes.

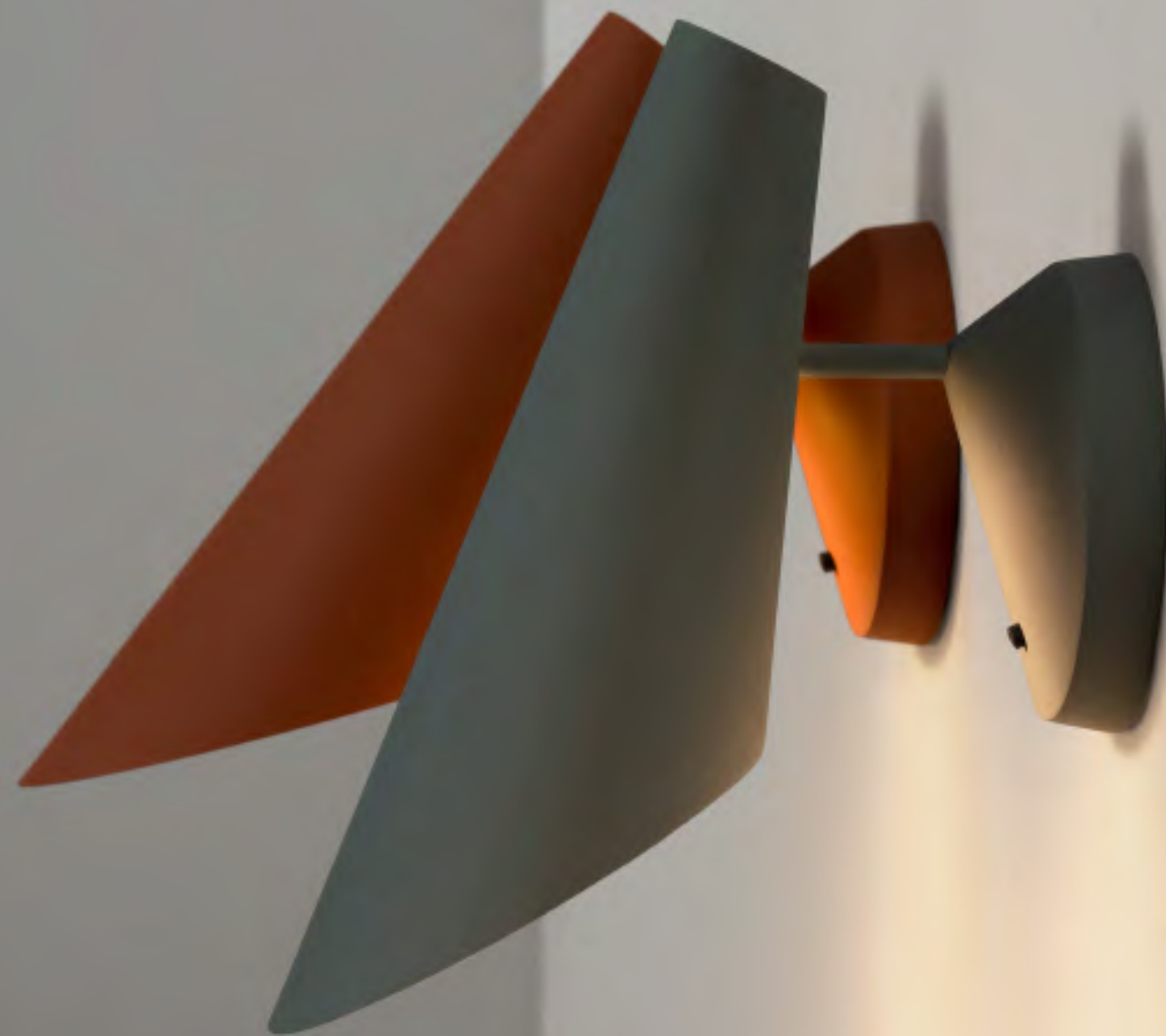

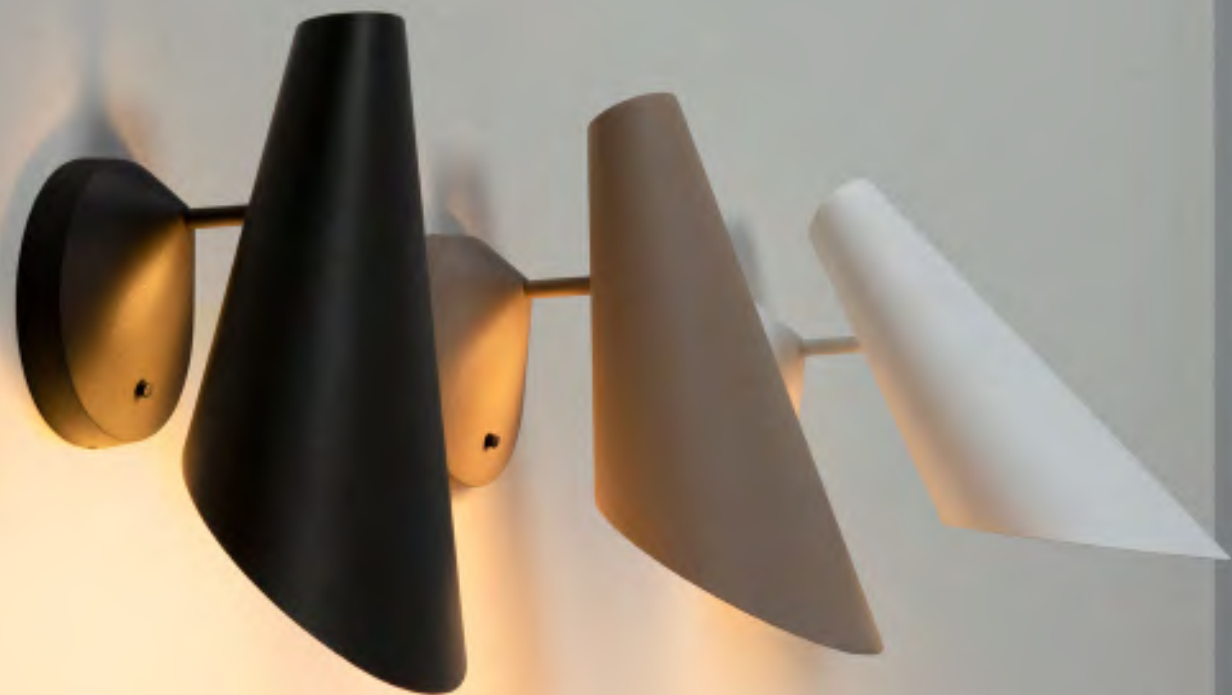

- 10 White (NCS S 0300-N)
- 21 Grey D1 (NCS S 7000-N)
- 25 Beige D1 (NCS S 4005-Y50R)
- 37 Terra Red (NCS S 4040-Y70R)
- 42 Blue M1 (NCS S 5010-B10G)

Shade: ABS + PC- Polycarbonate
 Tube: Steel
 Base: Aluminium

LED Colour Temperature

2700 K
 CRI>90

Control

Ref. 0720
 Analog: On/ Off
 Ref. 0721
 Analog: On/ Off; Push (Remote)
 Digital: DALI-2 (Remote)
 Smart: Casambi (Remote)



On/ Off switch on the base.

0720

15 x 17 x 26 cm



0721

15 x 17 x 26 cm

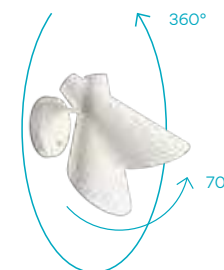

Origami

Design by Ramón Esteve.

Inspired by the Japanese art of paper folding, Origami provides gentle ambient light illumination while doubling up as a striking installation. Light radiates out from a series of distinctive geometric structures, creating a dialogue of light and shadow across the wall.



- 10 White (NCS S 0300-N)
- 29 Brown D1 (NCS S 8005-Y50R)
- 38 Terra Dark (NCS S 5040-Y70R)
- 53 Green M1 (NCS S 6005-G80Y)

Shade: ABS
 Diffuser: PC- Polycarbonate
 Lid: PC- Polycarbonate
 Arm: PC- Polycarbonate

LED Colour Temperature
 2700 K; 3500 K
 CRI>90

Control
 Analog: TRIAC

A maximum of 30 modules can be connected to a single connection point.

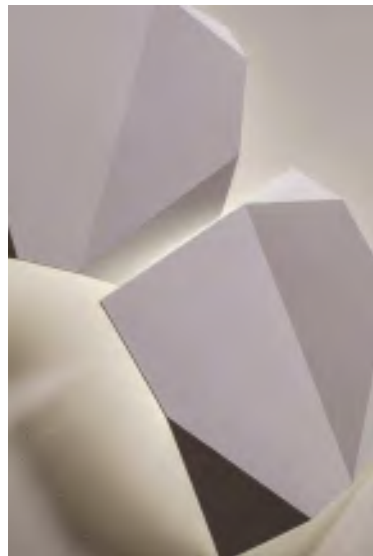

4506
 70 x 91 cm



4500
 30 x 30 cm



4501
 30 x 30 cm



4504
 53 x 63 cm



4508
 94 x 107 cm

Alpha

Design by Ramos & Bassols.

A wall lamp with basic lines and advanced lighting performance, its diffuser emits a warm, comfortable light.





7940
12 x 12 cm



7942
12 x 12 cm

- 18 Graphite & Black (RAL 7016 & RAL 9005)
- 93 White (RAL 9016)

Diffuser: PC- Polycarbonate
Lid: Zinc Alloy
Body: Aluminum
Lid: Aluminum

LED Colour Temperature

2700 K; 3500 K
CRI>90

Control

Analog: On/ Off

Ref. 7940
On/off switch on the front cover
Ref. 7942
Without switch



Puck



Design by Jordi Vilardell.

Glowing like a full moon, Puck's simple, spherical forms can be superimposed on top of one another, lending the whole an organic sensibility.





5410

24,4 x 6,6 cm

5412

27,2 x 7,7 cm

5425 5427

31,8 x 24,2 cm

● 03 White (RAL 9016)

Canopy: Aluminum
Diffuser: Blown-glass

LED Colour Temperature

2700 K; 3500 K
CRI>90

Control

Analog: On/ Off

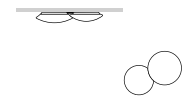
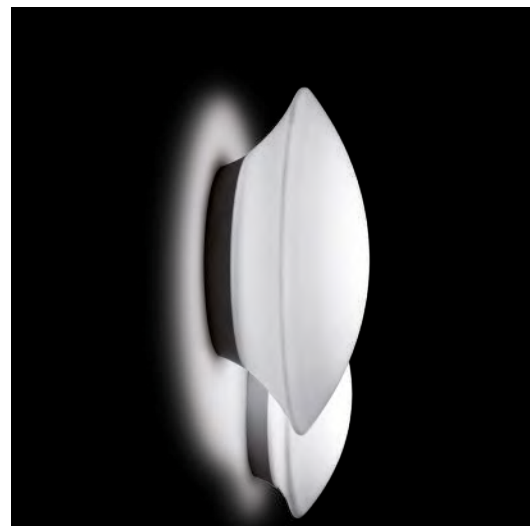

Puck Wall Art

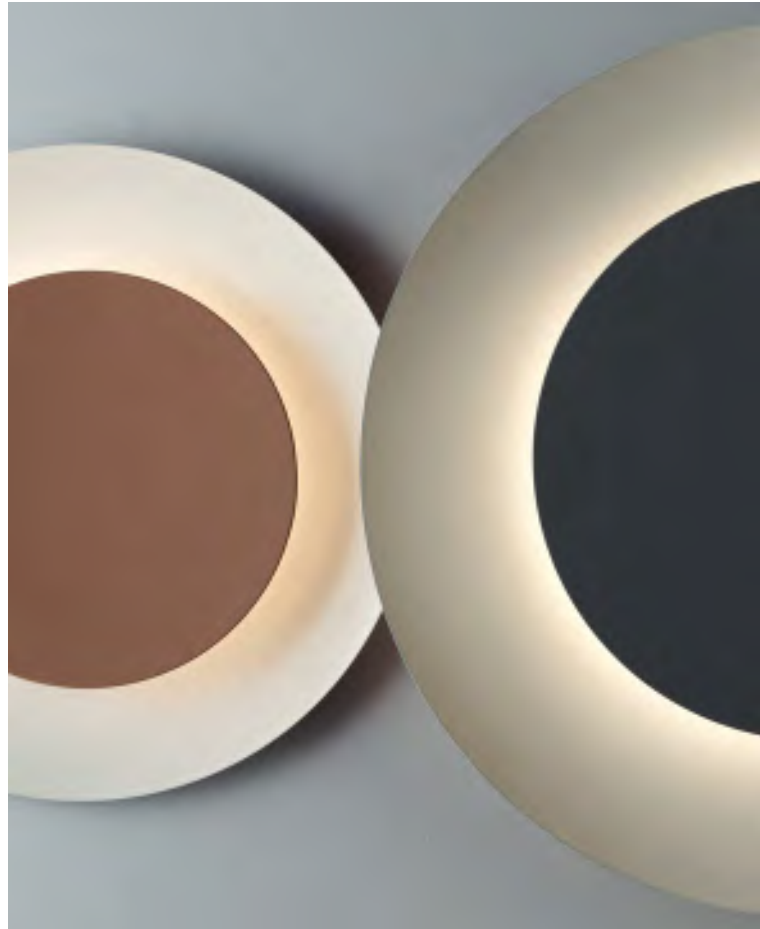

Design by Jordi Vilardell.

Puck Wall Art combines two circular wall lights of different sizes and colours, superimposed on top of one another, and combining to create a set of highly dynamic, sculptural compositions. The collection provides ambient indirect light and only requires a single electrical connection.



-  15 Grey L2 (NCS S 2500-N)
-  21 Black Grey (NCS S 7000-N)
-  28 Brown M1 (NCS S 4020-Y60R)
-  72 Black Grey & Grey L2 (NCS S 7000-N, NCS S 2500-N)
-  73 Brown M1 & Black Grey (NCS S 4020-Y60R, NCS S 7000-N)
-  76 Grey felt L1
-  77 Grey felt D1
-  71 Grey felt L1 & Grey felt D1

Diffuser: PC- Polycarbonate
 Shade: ABS
 Wall support: Aluminum

LED Colour Temperature

2700 K; 3500 K
 CRI>90

Control

Analog: Push; TRIAC; 1-10V
 Digital: DALI-2
 Smart: Casambi

A maximum of 8 modules can be connected to a single connection point

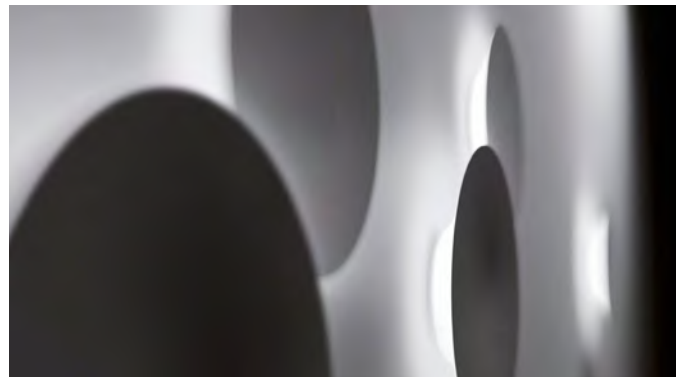

5470
 Ø 30 cm



5471
 Ø 40 cm



5472
 Ø 45 cm



5474
 Ø 46 cm



5476
 Ø 60 cm



5480
 58 x 58 x 6 cm



5481
 69 x 69 x 9 cm



5485
 68 x 68 x 9 cm



5487
 87 x 87 x 9 cm



5486
 87 x 87 x 11 cm



5491
 103 x 84 x 11 cm



Puck Wall Art is comprised of different disks to create a warm, visually sharp and mathematically creative effect. There are four sizes of disks, allowing the designer to play with varied combinations of indirect light. The resulting design comprises a set of highly dynamic, sculptural compositions.

North



Design by Arik Levy.

The North collection consists of a conical aluminum shade hanging from an adjustable carbon fibre rod. The rod and shade are disconnected from one another via a slim cable, directing the LED-powered light where needed in a dynamic system of adjustable parts.



**5630**

150 x 195 cm

For the North wall light, a slender rod rises from a base attached to the wall. The light source and shade are separated from the base, suspended delicately in mid-air from the tip of the rod. Available in four lacquered matte tones, it can be adapted to any style for both private and public use. North provides flat uniform light of a local yet flexible character.

- 10 White (NCS S 0300-N)
- 11 Black (NCS S 8500-N)
- 24 Beige M1 (NCS S 2005-Y50R)
- 42 Blue M1 (NCS S 5010-B10G)

Rods: Carbon fiber
 Shade: Aluminum
 Diffuser: PMMA
 Wall Plate: Steel

LED Colour Temperature
 2700 K; 3000K
 CRI>90
 3500 K
 CRI>80

Control
 Analog: Push

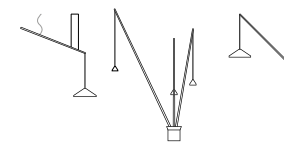

Pg 264/412 VOL 1 Pg 330 VOL 2



North combines pendant and wall application to provide elegant and adjustable solutions. Choose from different shade sizes for more focused or diffused illumination.

Halo



Design by Martín Azúa.

Halo's graphic simplicity lends it an ethereal quality. The fixture seems to float in mid-air, powered by invisible LEDs hidden within its opalized, linear diffuser.



2360
102,5 x 5,7 cm



When composed as a collection, Halo comes alive with new compositional value. Rotation around a central axis allows the light sticks to be positioned as desired, creating a luminous mural that bathes the surrounding wall in a diffuse light.

- 11 Black (NCS S 8500-N)
- 13 Off-White (NCS S 1000-N)

Diffuser: PMMA
LED support: Aluminum

LED Colour Temperature

2700 K
CRI>90
3000 K
CRI>80

Control

Analog: 1-10V
Digital: DALI-2
Smart: Casambi (Remote)

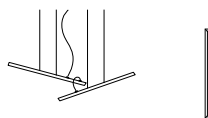

Pg 218 VOL 1 Pg 336 VOL 2



Sticks



Design by Arik Levy.

A pure solution for a minimalist interior, Sticks features luminaires of various lengths and incorporates a range of electrical connection options for seamless integration with the surrounding architecture.







Horizontal version with a UGR index <19 available



Linear flat diffuser



● 11 Black (S 8500-N)
Stick: Aluminum
Diffuser: PC- Polycarbonate

LED Colour Temperature
2700K; 3000K; 3500K
CRI>90

Control
Analog: Push, 1-10V
Digital: DALI-2
Smart: Casambi

Electrical connection options

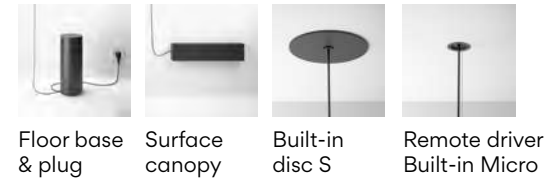

Connecting space application

Sticks offers a creative lighting toolkit for integrating light elements in an interior space, connecting the different architectural planes.

Connectable

The Sticks collection has three sizes: 1.5 m, 2 m, or 3 m, and they can be connected one to each other to a total maximum length of 6.5 meters per electrical connection.

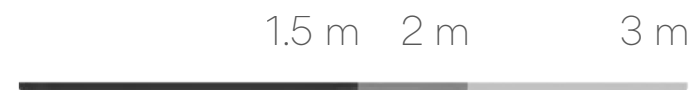

Sticks are connected one to each other with a 15 cm length cord.



Each stick rotates on its own axis, allowing light to be directed precisely where needed.



Wall-Wall



Wall-Wall (corner) / Wall-Ceiling

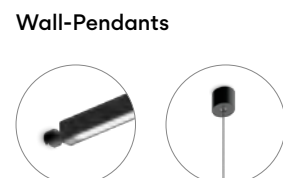

Wall-Pendants



Floor-Wall



WALL



Offset



Up&Down
Surface Grazer

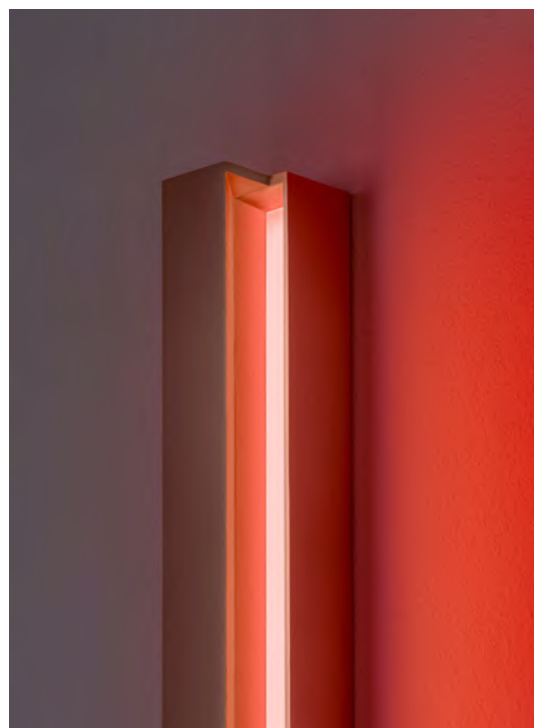

Colour
Mood Grazer

Design by Xuclà.

Offset combines soft, indirect light with an industrial, geometric silhouette. Offering a range of linear or angular luminaires and available in a range of different sizes, the system guarantees the versatility to adapt to any space.

- 11 Black (NCS S 8500-N)
- 24 Beige M1 (NCS S 2005-Y50R)
- 23 Warm White (NCS S 0502-Y50R)



Up&Down



- 11 Black (NCS S 8500-N)
- 23 Warm White (NCS S 0502-Y50R)
- 24 Beige M1 (NCS S 2005-Y50R)

Ref. 1770, 1772 and 1774
 Body: Aluminum
 Lens: PMMA

Ref. 1760, 1762, 1765 and 1767
 Body: Aluminum
 Diffuser: PC - Polycarbonate

LED Colour Temperature

Ref. 1770, 1772 and 1774
 Static White
 2700 K; 3000 K; 3500 K
 Ref. 1760, 1762, 1765 and 1767
 Infinite Colour (TW + RGB)
 CRI >90

Control

Ref. 1770
 Analog: On / Off; Push (Remote)
 Digital: DALI-2 (Remote)
 Smart: Casambi (Remote)

Ref. 1772 and 1774
 Analog: Push
 Digital: DALI-2
 Smart: Casambi

Ref. 1760, 1762, 1765 and 1767
 Smart: ProtoPixel*

*ProtoPixel products are compatible with all other DALI-2 products via a designated gateway (please consult us)

Up&Down Surface Grazer

| | | |
|--------------|----------------|----------------|
| 1770 | 1772 | 1774 |
| 7 x 7 x 4 cm | 7 x 100 x 4 cm | 7 x 160 x 4 cm |

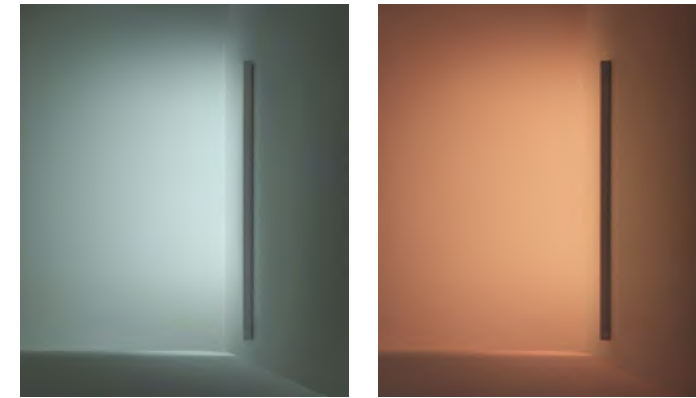
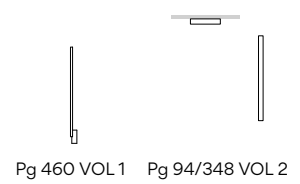

Colour Mood Grazer

| | | | |
|----------------|-------------|----------------|-------------|
| Left | Right | Left | Right |
| 1762 | 1760 | 1767 | 1765 |
| 7 x 125 x 5 cm | | 7 x 225 x 5 cm | |



A source of emotion

Colour is a source of emotion it can instantly set a mood, convey a feeling or generate a sense of wellbeing

Vibia's approach to coloured light invites the use of colour and gradients to create and experience different atmospheres, making them as natural and subtle as possible. Natural light is never mono-tonal. Gradients come in infinite colours.

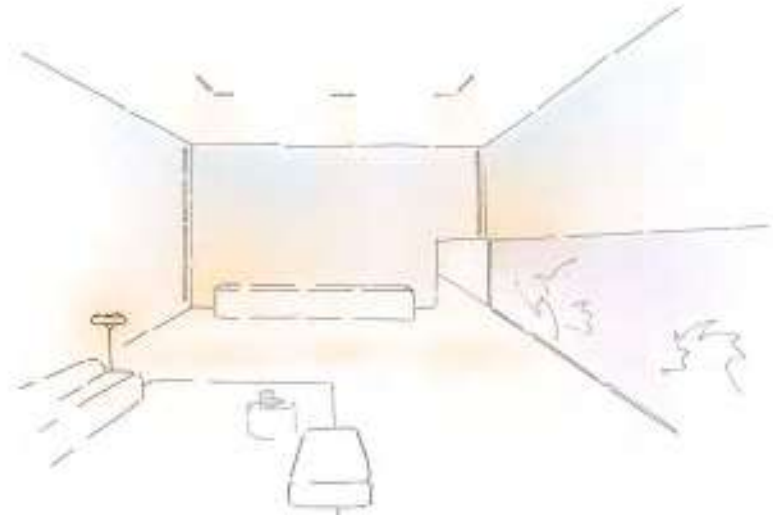

Vibia Chromatica colours of light

Static White

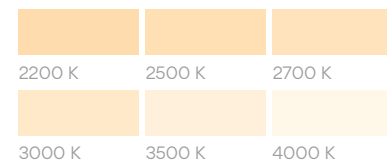

You can select any desired light -white, colour mood or gradient- and intensity manually from the analogic product interface. You can also integrate your selection into the control system for specific scene design and activate it using the Vibia App

Colour Moods

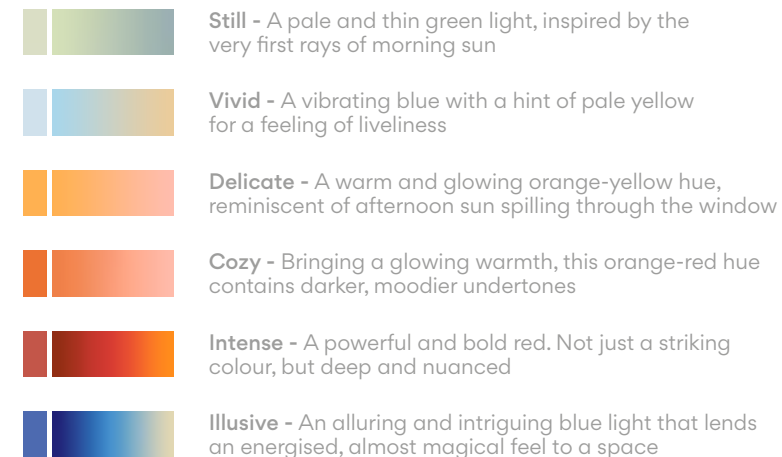

Contact Vibia Support Service at vibia.com for any kind of assistance or recommendation when designing an atmosphere of wellbeing, or if you require support with control system approach.

Vivid colour mood

Full of vitality, this is a brisk and honest light. The solid colour is a vibrating blue with a hint of warmth, while the pale yellow in the gradient gives a feeling of liveliness — perfect for boosting energy and focus.



Outdoor

Outdoor

Bamboo
414

Empty
408

Break
430

June
446

Break Plus
435

Meridiano
450

Brisa
402

Origami
388

Class
456

Out
378

Dots
Glass
372

Palo Alto
394

Dots
Outdoor
360

Wind
422

Dots Outdoor

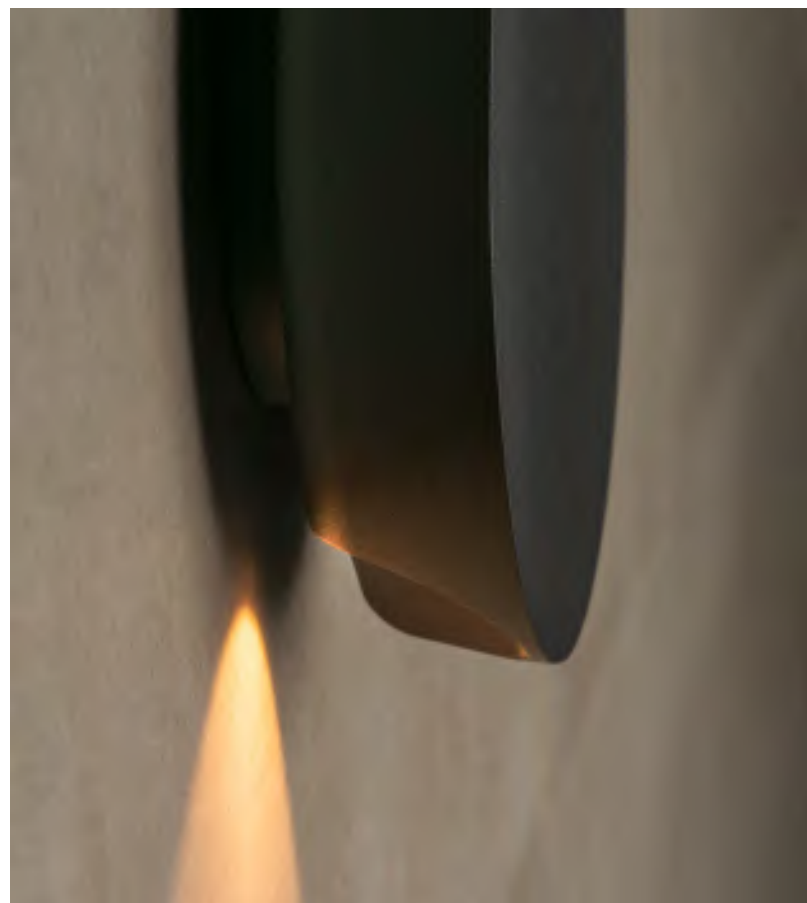

Design by Martín Azúa.

Diminutive, compact and easily installed, Dots Outdoor is the perfect solution for subtle outdoor illumination. Designed to nestle discreetly into the undergrowth of a garden or patio, Dots shines at night with a diffuse or focused glow from an invisible source.

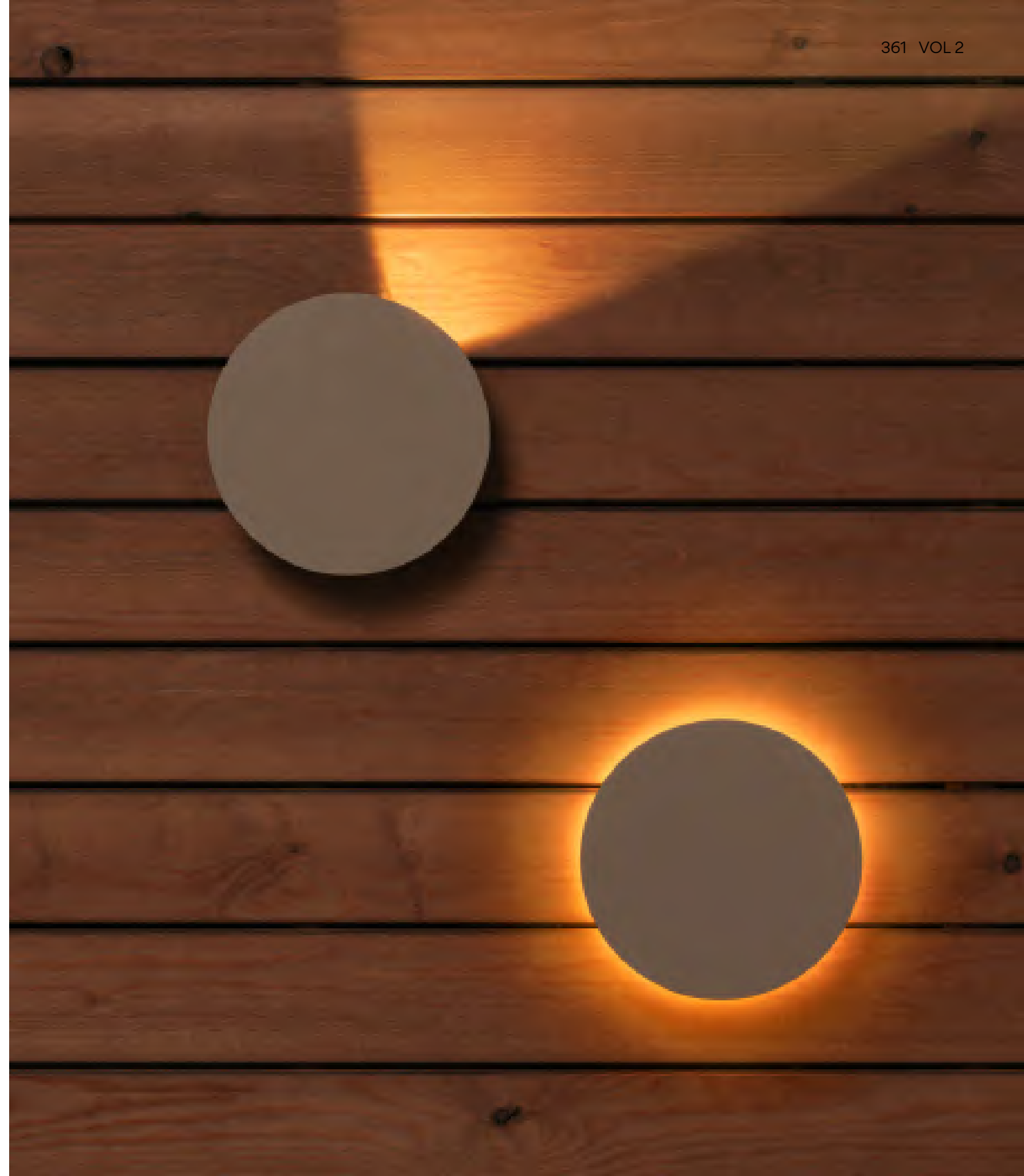





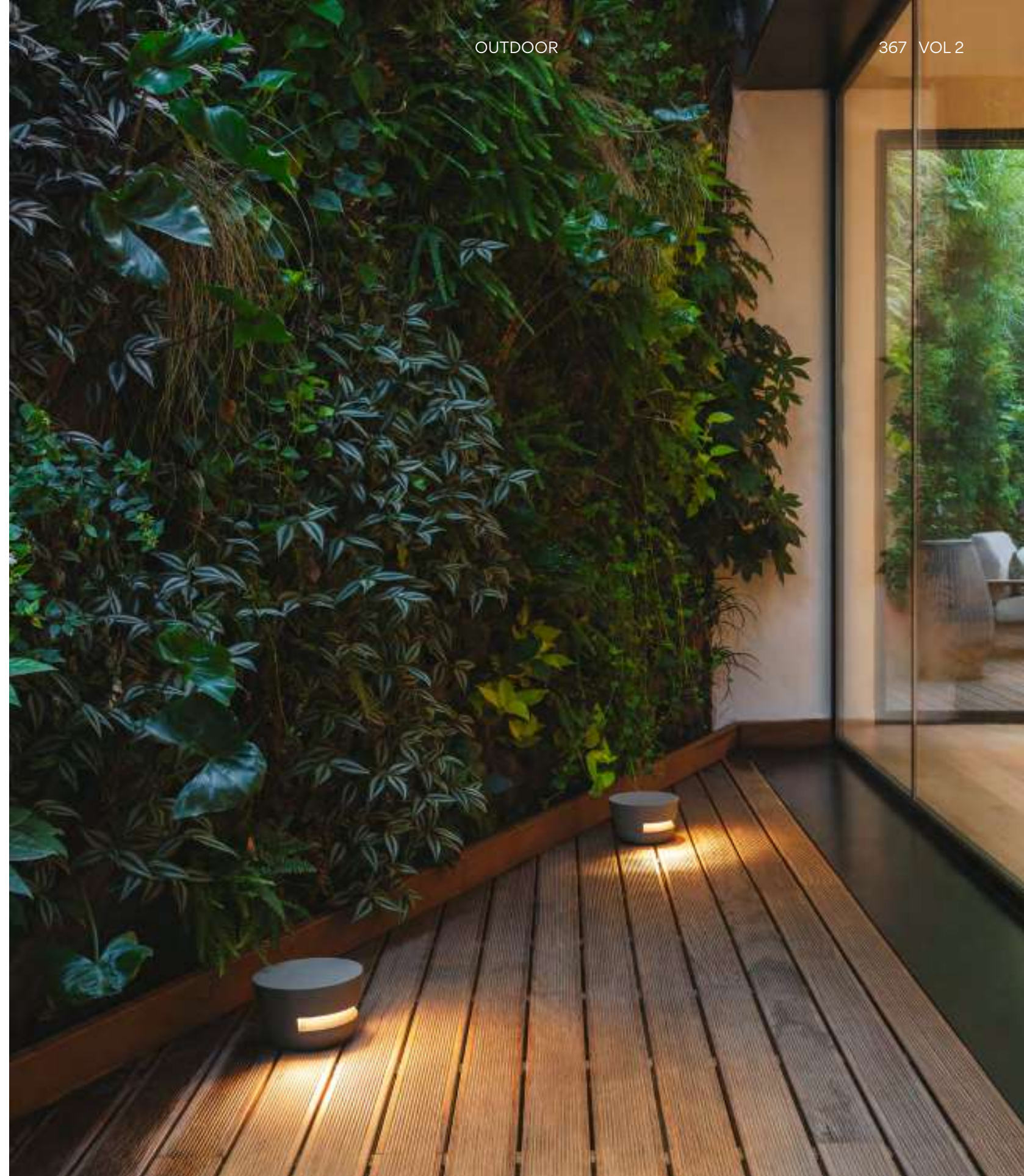



To connect interior and exterior living spaces, designers are increasingly bringing indoor qualities to the outdoor environment. Whether you want to enhance the existing scenery, integrate an outdoor seating area, or simply add a layer of security, Dots offers an extensive range of durable and weather resistant lighting solutions.





4684
Ø 20 cm



4688
Ø 20 cm

- 22 Graphite Black (NCS S 8000-N)
- 25 Beige D1 (NCS S 4005-Y50R)
- 53 Green M1 (NCS S 6005-G80Y)

Body: Aluminum
Diffuser: PC- Polycarbonate

LED Colour Temperature

Ref. 4684, 4688
2700 K; 3500 K

Ref. 4695, 4697, 4700, 4702
2700 K

CRI>90

Control

Analog: On/ Off; 1-10V
Digital: DALI-2 (Remote)
Smart: Casambi (Remote)

IP65 | IP66 | Bi-volt



4695
Ø 20 x 12 cm



4697
Ø 15 x 9 cm



4700
Ø 20 x 12 cm



4702
Ø 15 x 9 cm



Dots Glass



Design by Martín Azúa.

Sheathed in layers of transparent optical glass, the LED source within the Dots Glass diffuser generates a warm, 360-degree glow with a pulsating ambient effect.

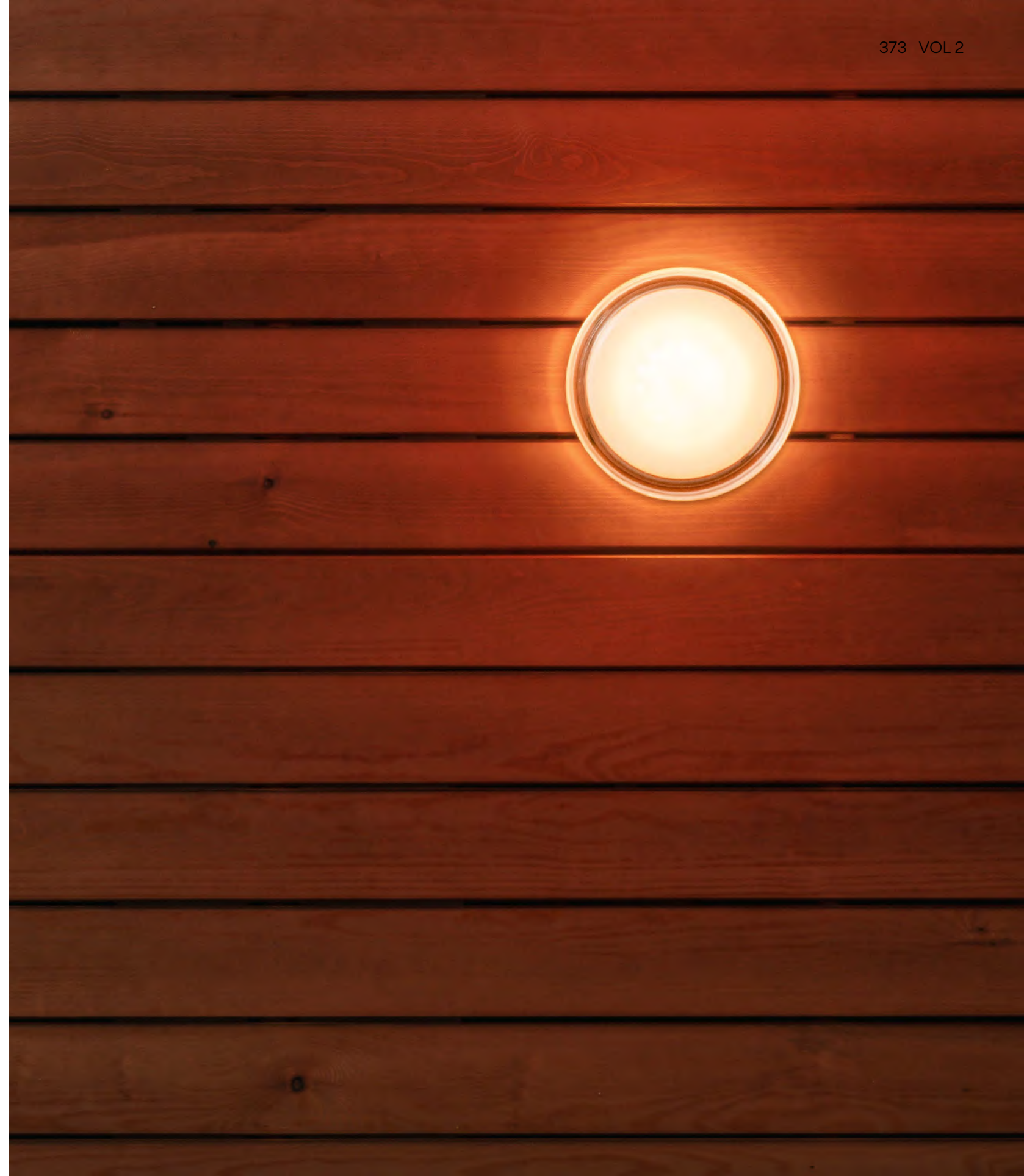

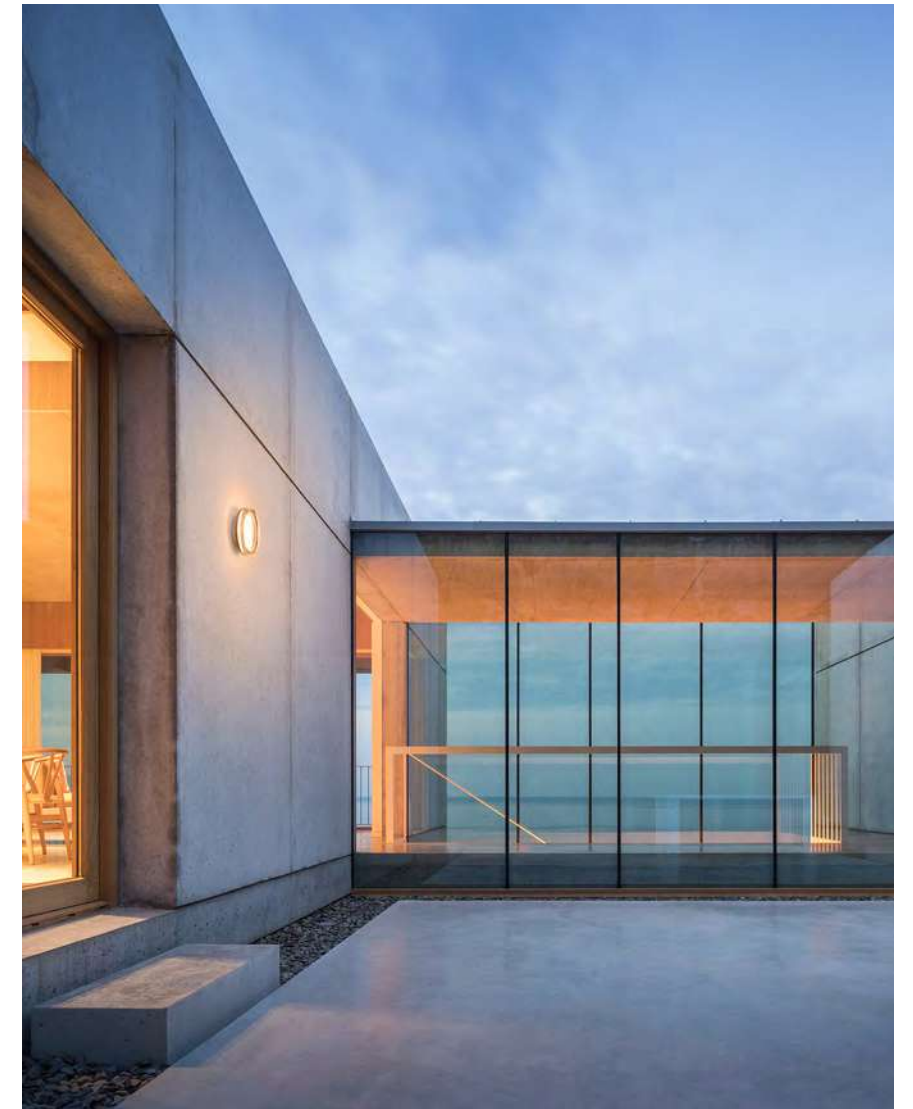

Ideal for transitional or walkway lighting, Dots Glass projects a subtle, lunar glow, highlighting the texture of its surrounding environment. Planted as a single star in the darkness, or combined with other elements of the collection, this sleek addition lends a delicate aesthetic.



4680
 Ø 20 cm

● 10 White (NCS S 0300-N)

Body: Aluminum
 Diffuser: Optical Glass

LED Colour Temperature
 2700 K; 3500 K
 CRI>90

Control
 Analog: On/ Off; 1-10V
 Digital: DALI-2
 Smart: Casambi (Remote)

IP66



Out

Design by Víctor Carrasco.

Out is a romantic response to the global transition towards outdoor living. Available in a range of soothing colours, this innovative floor fixture projects a diffuse downlight that's ideal for illuminating a table or communal area.



47 Green L1



● 22 Graphite Black

Out brings the intimacy of indoor lighting outdoors.



● 25 Beige D1



23 Warm White

Indoor & outdoor

Linking interior and exterior spaces has a significant impact on our sense of wellbeing. As we enter an era where outdoor space is becoming increasingly essential, design professionals are turning their attention towards breaking down traditional architectural barriers.



36 Soft Pink



● 23 Warm White

● 36 Soft Pink

Out brings a poetic aesthetic, its slender stem extending vertically into the air before bending over in a broad arch. Forming islands of light in the darkness, its balanced structure and large scale allow people to pass underneath without complicating the space.

● 47 Green L1





- 22 Graphite Black (NCS S 8000-N)
- 23 Warm White (NCS S 0502-Y50R)
- 25 Beige D1 (NCS S 4005-Y50R)
- 36 Soft Pink (NCS S 1010-Y50R)
- 37 Terra Red (NCS S 4040-Y70R)
- 47 Green L1 (NCS S 4005-G80Y)

Tube: Stainless Steel
 Shade: Aluminium
 Diffuser: PE- Polyethylene

LED Colour Temperature

2700 K
 CRI>90

Control

Ref. 4270
 Analog: Push
 Smart: Casambi; ProtoPixel*

*ProtoPixel products are compatible with all other DALI-2 products via a designated gateway (please consult us)

Ref. 4275
 Digital: DALI-2
 Smart: Casambi (Remote)



Pg 468 VOL 1
 Pg 378 VOL 2

4270. Cable with switch



4270 Not Fixed IP44

211 x 242 cm



4275 Bolt-down "hard wired" IP65

211 x 242 cm

Origami

Design by Ramón Esteve.

Inspired by the Japanese art of paper folding, Origami offers gentle exterior illumination while doubling up as a striking installation. Designed to climb like ivy, light radiates out from a series of distinctive geometric structures, creating a play of light and shadow across a wall.







4506

70 x 91 cm



4500

30 x 30 cm



4501

30 x 30 cm



4504

53 x 63 cm



4508

94 x 107 cm

Origami invites you to get creative. A single point of connection between pieces allows professionals to make as many patterns or configurations as desired, combining functionality with infinite versatility.

- 10 White (NCS S 0300-N)
- 29 Brown D1 (NCS S 8005-Y50R)
- 38 Terra Dark (NCS S 5040-Y70R)
- 53 Green M1 (NCS S 6005-G80Y)

Shade: ABS
Diffuser: PC- Polycarbonate
Lid: PC- Polycarbonate
Arm: PC- Polycarbonate

LED Colour Temperature
2700 K; 3500 K
CRI>90

Control
Analog: TRIAC

IP65

A maximum of 30 modules can be connected to a single connection point

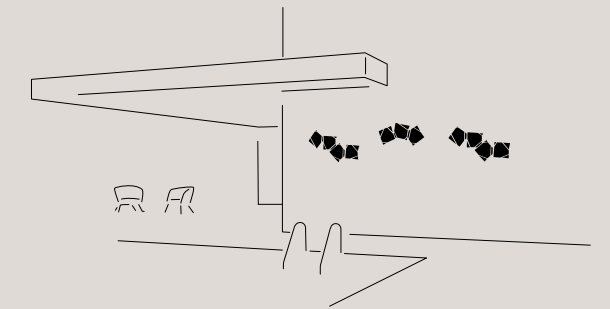
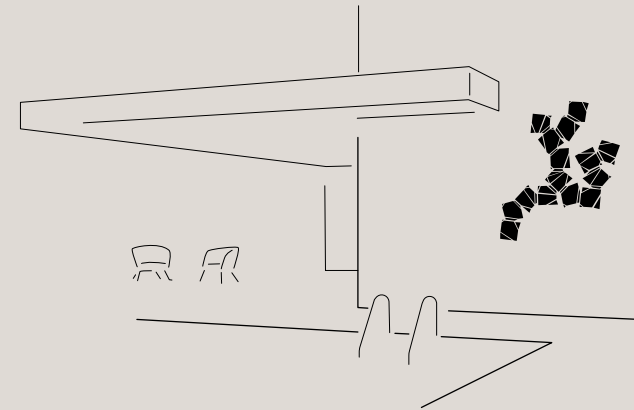

Palo Alto

Design by Xuclà.

Palo Alto is defined by a linear, angular silhouette. Industrial in style yet natural in form, it recalls a tree whose steel “branches” are embedded with LEDs, illuminating the surrounding landscape with a diffuse downlight.



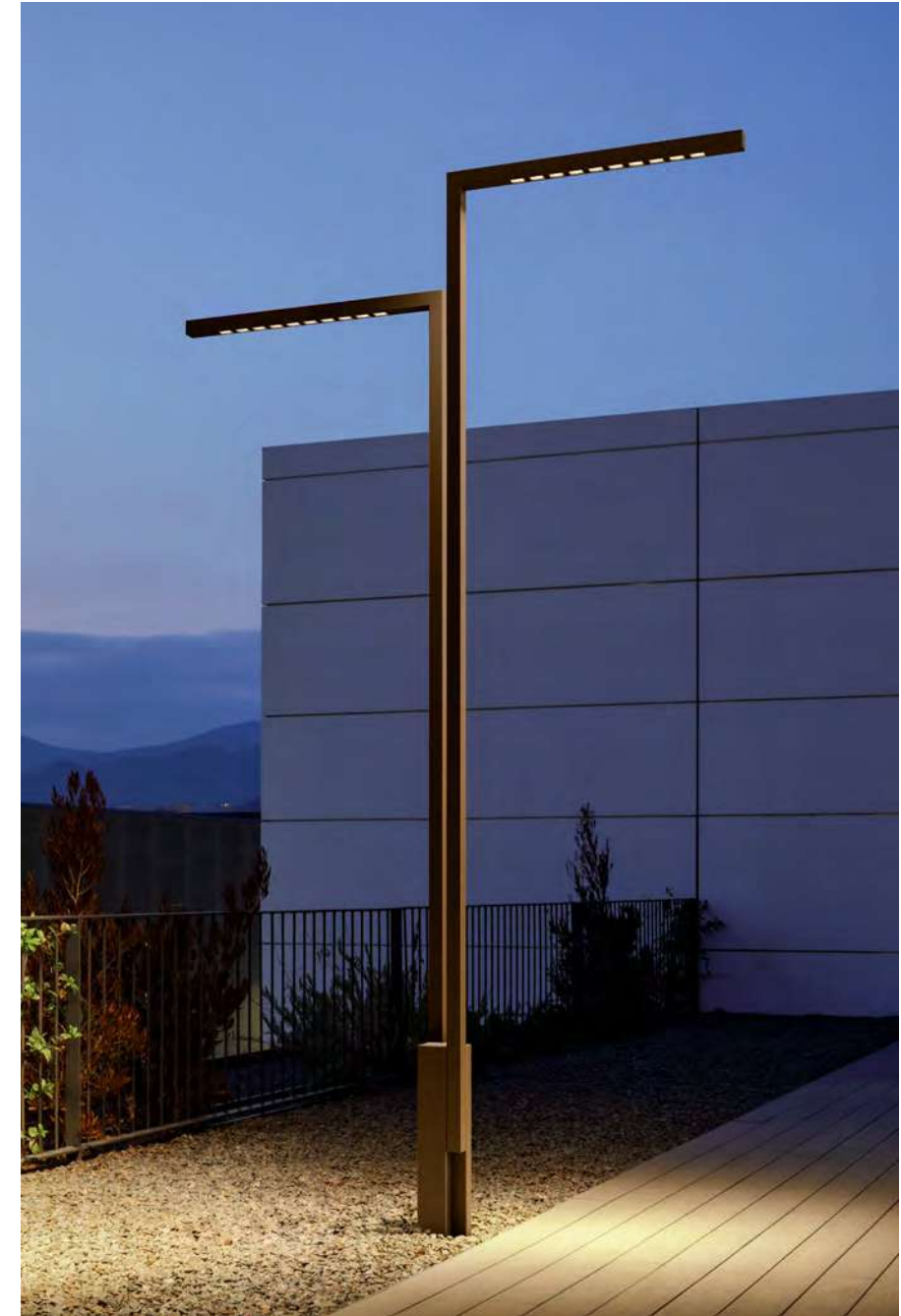

Thanks to its heights, shapes and angles, Palo Alto integrates seamlessly into any outdoor environment



It is offered in various minimalist shapes and can be displayed individually or in a group to resemble a stand of trees. The upper reaches of the sturdy steel fixture are fitted with slim swaths of LEDs directed downwards to create a diffused, ambient glow.



Ground surface mounted.



4510
35 x 90 cm



4516
85 x 280 cm

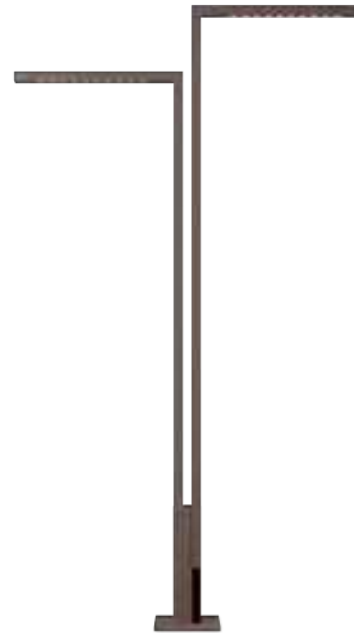

4539
85 x 310 cm



4540
136 x 310 x 161 cm

- 22 Graphite Black (NCS S 8000-N)
- 29 Brown D1 (NCS S 8005-Y50R)

Body: Steel
Cover: Steel

LED Colour Temperature
2700 K; 3500 K
CRI>90

Control
Analog: On/ Off

IP65



Brisa

Design by Lievore, Altherr, Molina.

Inspired by the forest blue bellflower, Brisa is the essence of flawless landscape integration. Its stylised silhouette and natural inspiration bring a subtle charm to any exterior.



Brisa adds a nature-inspired accent to any space. True to its name, which means breeze in Spanish, Brisa's silhouette is delicate and graceful. Its long, slender stem is topped with a hanging, conical shade that beautifully captures the bloom's languid look. The simple architecture and distinctive bowed head lend it a quiet presence that accents an outdoor space rather than overpowering it. Offered with 1, 3, or 5 arms, it resembles a solitary plant or grouping of flowers in a natural setting. The LED-powered light source casts a warm, bright beam, making it ideal for focused illumination. The collection is available in a surface mounted or built-in style.





4625
10 x 103 cm



4630
10 x 100 cm



4635
22 x 99,5 x 23 cm



4640
30 x 100 x 27,5 cm

- 07 Khaki (RAL 7039)
- 54 Oxide (RAL 8014)

Shade and Base: Aluminum.
Disc: Stainless steel.
Vertical tube: Steel.

LED Colour Temperature
2700 K; 3500 K
CRI>90

Control
Analog: On/ Off

IP64 IP65



Empty

Design by Xuclà.

Empty, lends itself to Vibia's 'furniture meets light' concept. Incorporating a table, stool and light fixture into a single three-dimensional entity, each geometric structure glows with subtle, indirect light from an invisible source.



4125
45 x 45 cm



4130
45 x 70 cm



4135
25 x 25 cm



4136
25 x 55 cm

- 18 Polymer Concrete Grey (NCS S 2002-B50G)
- 22 Graphite Black (NCS S 8000-N)

Body: Polymer Concrete
Diffuser: PMMA

LED Colour Temperature
2700 K; CRI>80
3500 K; CRI>90

Control
Analog: On/ Off

IP66

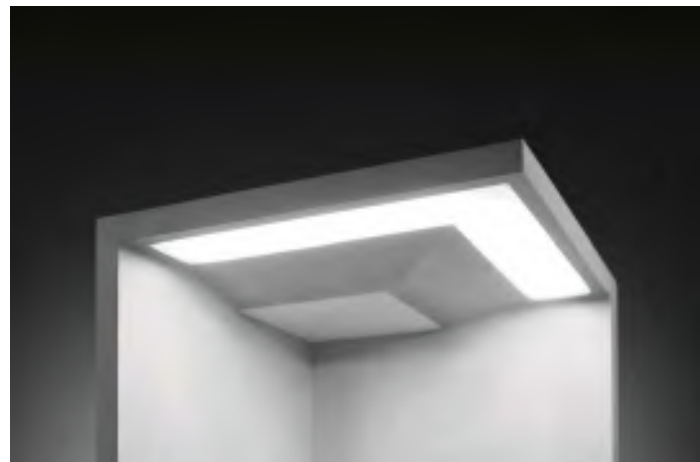
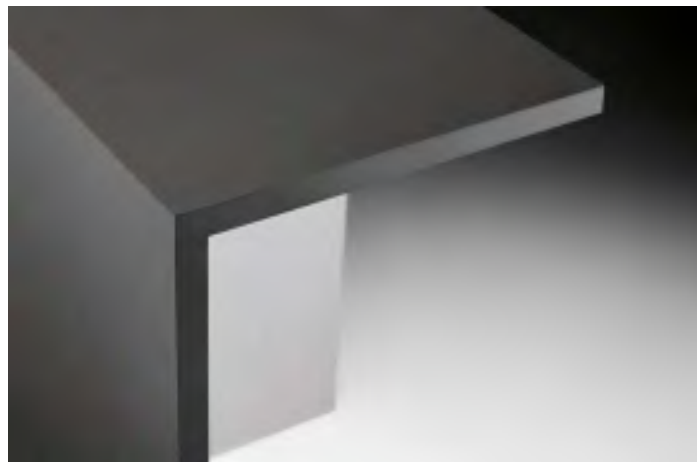

Floor lamp and furnishing in one, Empty's crisp angles create a cantilevered perch that serves as a side table or stool, while making a sleek modernist statement. A LED light source tucked discreetly under the seat casts a warm glow that's ideal for walkways or general exterior illumination.



Bamboo



Design by Antoni Arola & Enric Rodríguez.

Bamboo's lean, natural form perfectly lends itself to an outdoor setting. Studded with LEDs, it seamlessly integrates with the landscape while adding a wash of light to walkways and common spaces.







Bamboo was clearly inspired by its namesake. Characterised by a slender silhouette that blends in with the existing flora, the fixture can be 'planted' into decking or gravel, illuminating the adjacent wall with lively "spots" of light.

- 07 Khakhi (RAL 7006)
- 54 Oxide (RAL 8017)
- 58 Off-White (Pantone Warm Gray 2U)

Cane: PES+FG- Fiberglass
 Diffuser: PMMA

LED Colour Temperature
 2700 K; 3500 K
 CRI>90

Control
 Analog: On/ Off

IP66



4820
 19 x 6 cm



4812
 Ø 40 x 270 cm



4811
 Ø 35 x 270 cm



4810
 Ø 43 x 190 cm



4805
 6 x 270 cm



4804
 6 x 190 cm



4801 4803
 6 x 90 cm



4800 4802
 6 x 60 cm

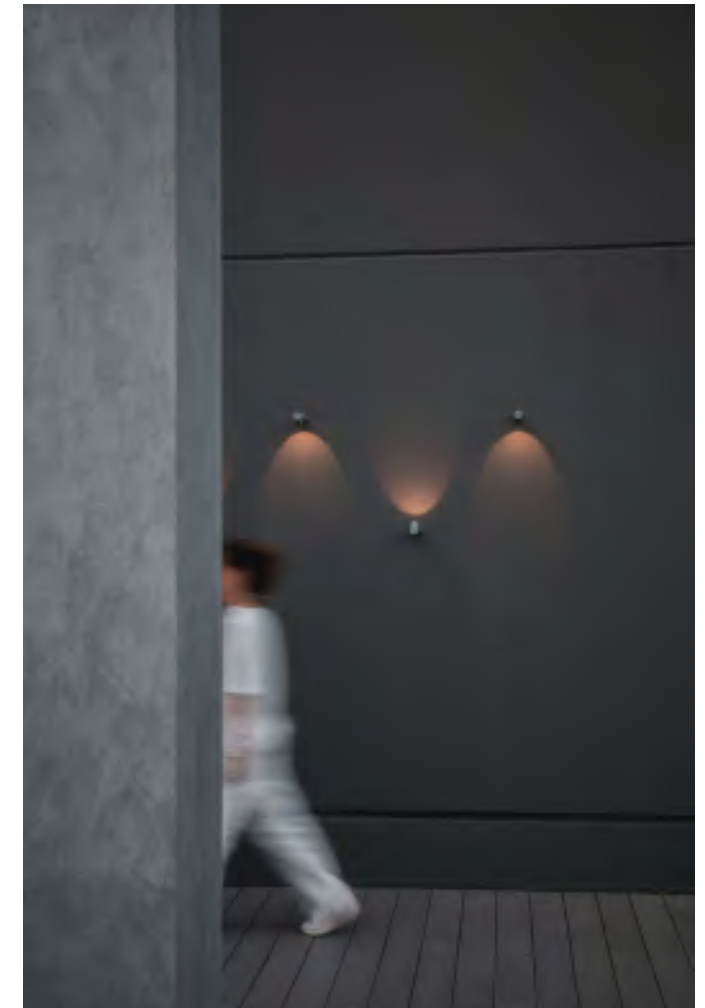

Ref. 4800, 4801, 4820 surface mounted.

Ref. 4802, 4803, 4804, 4805, 4810, 4811 and 4812 built-in installation.

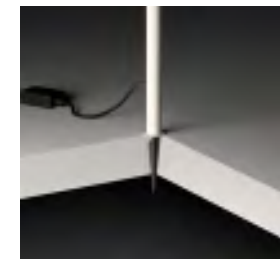

Wind



Design by Jordi Vilardell.

A perfect marriage of technology and tradition. Wind's drum shade is made of fibreglass, an innovative webbed texture and pattern that elevates the visual contribution of this timeless silhouette.





Besides its large scale, the principle characteristic of the Wind collection is its materiality. The traditional drum shade is made from delicately woven fibreglass, producing a uniquely textured surface with a warm, ambient lighting effect.



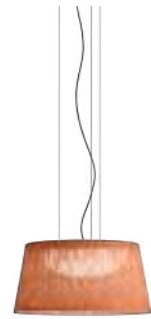

4072
Ø 60 cm



4077
Ø 60 cm



4078
Ø 120 cm

- 27 Sand (NCS S 1505-Y50R)
- 53 Green M1 (NCS S 6005-G80Y)
- 61 Ocre Red (NCS S 3050-Y60R)

Shade: FG- Fiberglass
 Base: FG- Fiberglass
 Diffuser: FG- Fiberglass
 Canopy Plate: Steel
 Lid: Steel

LED Colour Temperature

2700 K
 CRI>90

Control

Analog: On/ Off

Ref. 4057, 4062, 4067 **IP64**

Ref. 4072, 4077 **IP65**

Ref. 4078 **IP20**

Ref. 4057
 Shade: FG- Fiberglass
 Weight: Concrete
 Lid: Steel
 Diffuser: PMMA



4057
Ø 60 x 191 cm



4062
Ø 120 x 195 cm



4067
Ø 60 x 166 cm

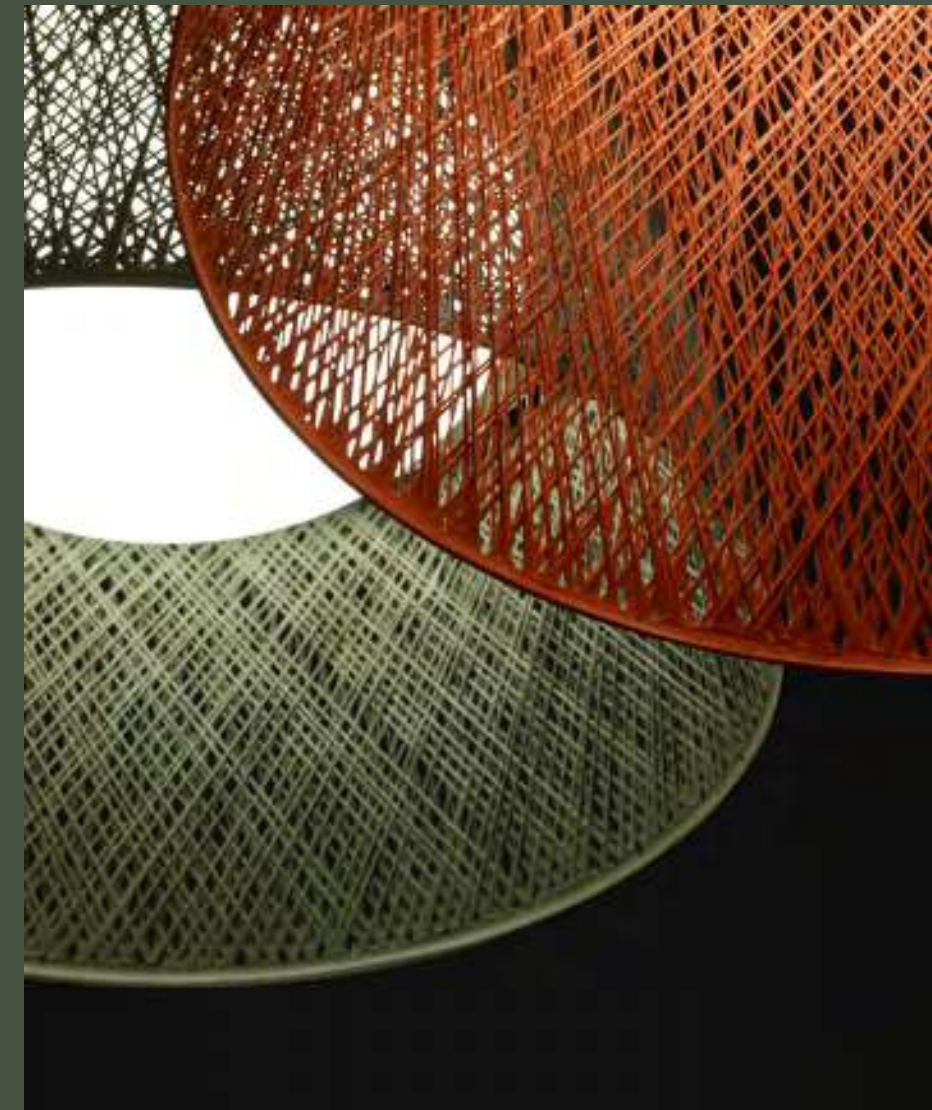
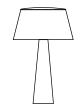

Break



Design by Xuclà & Alemany.

Break is distinguished by its architectural attitude. A series of cubic volumes provide indirect downlight while doubling up as a dynamic sculptural presence.





4101
25 x 81 cm



4106
25 x 43 cm



4108
48 x 38 cm

The Break collection consists of a bevelled cube with a recess from which light escapes, and a pair of blocks stacked on top of one another, the space between them allowing light to pass through. Dotted in pairs and groups of three, Break's graphite black lacquer and concrete finishes blend effortlessly with an industrial aesthetic.

- 80 Concrete (Natural finish)
- 22 Graphite Black (NCS S 8000-N)

Head: Concrete
Base: Concrete
Diffuser: PMMA
Body: Steel

LED Colour Temperature
2700 K
CRI>80

Control
Analog: On/ Off

IP66





Break Plus

Design by Xuclà.

Designed to blend instinctively with the architecture in which it exists, Break Plus converts any wall into a three dimensional mural. Arranged individually or as a group, it consists of four geometric volumes that cast beams of diffuse light upwards, downwards -or in both directions- creating a dynamic dialogue between light and shadow.





Break Plus guarantees seamless adaptation to the surface upon which it is mounted. The collection's lacquered matte finish adds a natural, grainy texture that complements its clean, geometric expression.





Characterised by its stylized silhouette and available in four muted Chromatica colours, these playful units display an ethereal lighting effect on the wall.





Break Plus is evocative of a roof tile or brick, designed individually to connect as a whole. Integrating into the architecture of any space, the collection presents five geometric models that provide spatial depth and aesthetic plasticity to an otherwise flat surface. When grouped together, the collection creates a dynamic dialogue between light and shadow: light is reflected from the interior of each volume, drawing a single or double or beam across the wall, which merge to establish a lattice of oblique lines. Easily installed and with on/ off, Dali and Casambi control systems, its lacquered matte finish adds a hint of graininess that complements its geometric form.

A singular study in high performance technology, Break Plus is designed to withstand all weather conditions. Surface mounted and easily maintained, its unique form prevents water from stagnating, making it the ideal choice for both private residential properties as well as larger commercial projects.



4112

12 x 14 cm

4114

12 x 14 cm

4116

21 x 34 cm

4118

19 x 32 cm

- 22 Graphite Black (NCS S 8000-N)
- 25 Beige D1 (NCS S 4005-Y50R)
- 37 Terra Red (NCS S 4040-Y70R)
- 95 Primer (NCS S 1000-N)

Body: Aluminum
Diffuser: PC- Polycarbonate

LED Colour Temperature

2700 K; 3500 K
CRI>90

Control

Analog: On/ Off
Digital: DALI-2 (Remote)
Smart: Casambi (Remote)

IP65

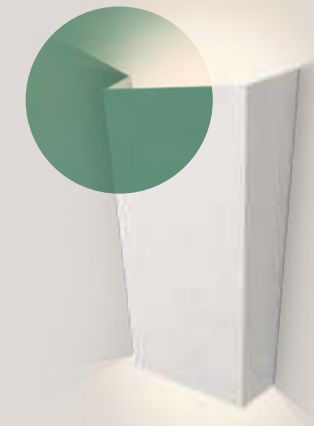

Primer finish: customisable on site. Break Plus is offered in a primer tone, which allows for seamless integration within the surrounding architecture and adaptation to the project needs as it can be painted in any desired colour.



June

Design by Ana Mir + Emili Padrós (Emiliana Design Studio).

Inspired by traditional lanterns, June's moon-like spheres cast a warm, ambient glow, lending a touch of nostalgia to an outdoor space.





4785
Ø 9 x 120 cm

4780
Ø 9 x 80 cm

Inspired by traditional lanterns, June translates the iconic image of illuminated globes into a refined collection. Its moon-like spheres recall garlands festooned throughout a courtyard, garden, or patio, casting a warm, ambient glow. The LED-powered fixture bathes a surface in gentle, diffuse illumination for an intimate atmosphere.

● 54 Brown (Pantone Black U)

Diffuser: Opal blown glass
Tubes: Steel

LED Colour Temperature

2700 K
CRI>90

Control

Analog: On/ Off

IP65



Meridiano

Design by Jordi Vilardell & Meritxell Vidal.

Composed of a structure of corrugated steel rods, Meridiano radiates with a burst of light and shadow that enriches its surrounding environment. As a floor lamp, it doubles up as outdoor furniture; as a wall sconce, it animates a bare façade with a dynamic sunburst motif.





4720
Ø 26 cm

Functioning as both ambient lighting and dynamic sculpture, multiple fixtures can be positioned at random to cast a luminous web of spokes, artfully filling a large blank expanse of wall. Equipped with an LED light source ideal for exterior use, the sconce can be paired with the floor version to flawlessly integrate a garden seating area or poolside terrace with an exterior wall.

- 07 Khakhi (RAL 7006)
- 58 Off-White (Pantone WARM GRAY 2U)

Seat: PU- Polyurethane
Rods: Steel
Arm: Steel
Diffuser: Glass
Base: Steel

LED Colour Temperature

LED 2700 K; CRI>90
LED 3500 K; CRI>80

Control

Analog: On/ Off

IP64 IP65



4710
Ø 64 cm



4715
Ø 92 cm





Class

Design by Sebastian Herkner.

A timeless and elegant solution for outdoor environments, Class combines the refined aesthetic of a patio light with the functional performance of a bollard. Consisting of a durable aluminum shaft and fluted glass diffuser, it washes the space with a gentle luminescence.



“Class emphasizes its architectural elegance in its vertical metal structure, as well as the soft waves in the borosilicate glass tube. The structured glass spreads the light in a soft patterned way on the facade, the terrace and the greenery around”.

Sebastian Herkner



Forming a delicate H, the metal starts to curve at its peak, enclosing the tube from above and below with gentle precision.







Class's translucent glass tube is fluted, defined by even grooves that allow the light to pass softly through it while the source remains obscured. Each tube is supported by a robust aluminium shaft, available in two different heights and with a choice of individual, multiple or asymmetrical luminaires. The matte black of the shaft contrasts with the smooth surface of the glass tubes, a satisfying combination of textures reminiscent of the traditional gas lamp. Designed to give a little sway with the breeze, the taller free standing shaft bathes a wide area of exterior space in its warm glow. In response, the shorter model projects a soft transition radiance from below.

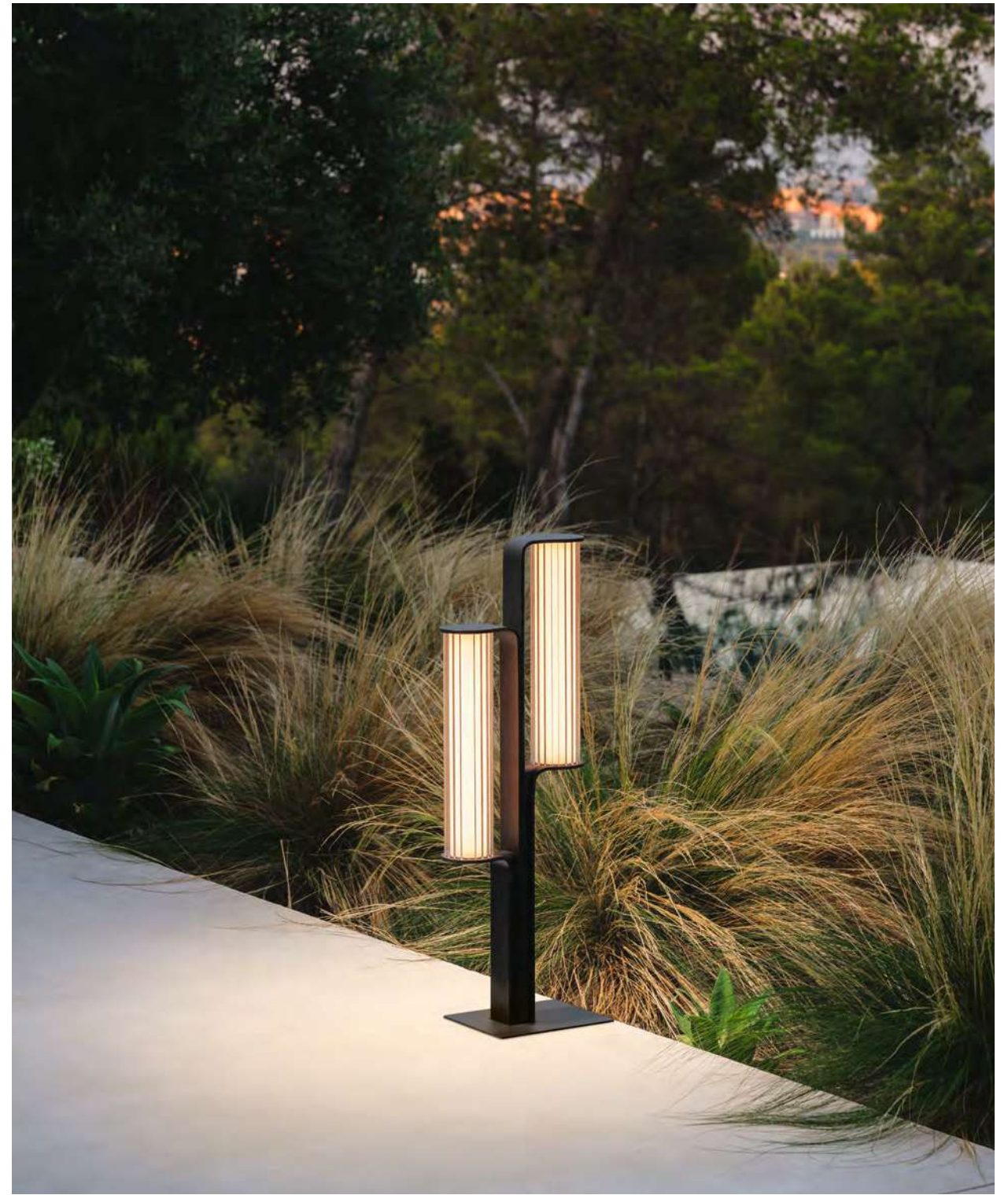



2810
28 x 250 cm



2815
28 x 250 cm



2800
22 x 78,5 cm



2805
22 x 78,5 cm



2820
18 x 60 cm



2825
18 x 96 cm

● 11 Black (NCS S 8500-N)

Body: Aluminum
Glass: Borosilicate glass
Diffuser: Opal PC- Polycarbonate

LED Colour Temperature

2700 K
CRI>90

Control

Analog: Push
Digital: DALI-2
Smart: Casambi (Remote)

IP65

Class's translucent glass tube is fluted, defined by even grooves that allow the light to pass softly through it while the source remains obscured.





Lighting Typologies

Support Portfolio

Lighting Typologies

Diffuse



Flat Diffuser

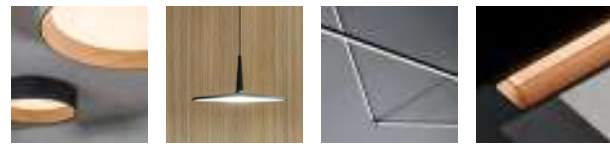

General Proximity Linear Linear High Comfort

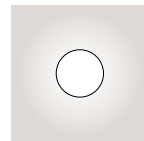

Volumetric Diffuser

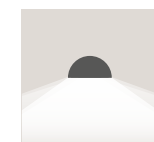

Hidden Diffuser

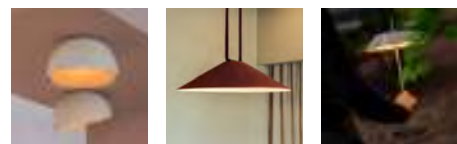

General Proximity

Indirect

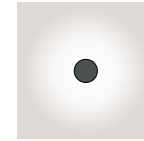

Reflected

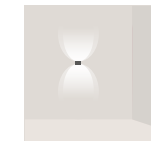
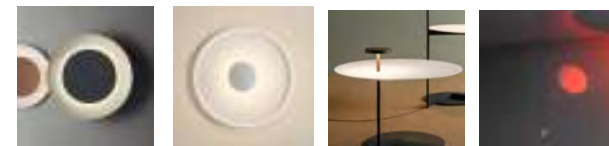

Surface Grazer

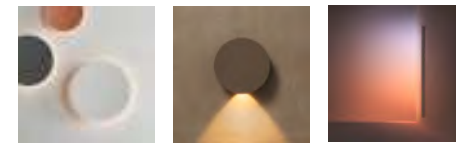

360° Direct Mood Grazer



Wall Washer

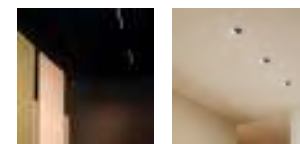

Linear Spot

Direct



Spotlight

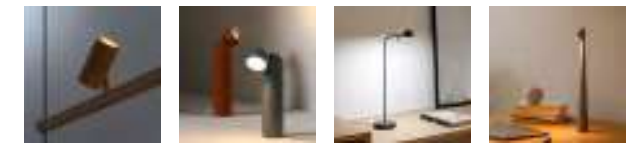

Accent Reading



Downlight



Accent



Linear High Efficiency Low Glare



Lighting Typologies

Diffuse

Flat Diffuser



Comfortable, uniform illumination with soft shadows, subdued highlights and little visual hierarchy



General
First layer of basic, general illumination

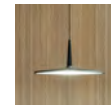

Close Proximity
Lighting applications for illumination in close proximity to the user



Linear
Linear lighting applications for functional and graphic illumination



Linear High Comfort
Linear lighting applications with High lighting and comfort levels (UGR <19) for illumination in close proximity

Volumetric Diffuser



Subtly directed, diffused light that generates a soft hierarchy of light on to the illuminated surface.



Hidden Diffuser

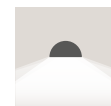

Subtly directed diffused light that generates a soft hierarchy of light on to the illuminated surface



General
First layer of basic, general illumination

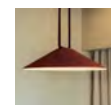

Close Proximity
Lighting applications for illumination in close proximity to the user

Indirect

Reflected



Creation of visual hierarchies within the luminaire itself, emphasising the materiality and texture of the product

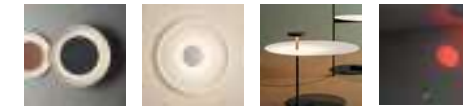

Surface Grazer



Creation of visual hierarchies through projected light, emphasising the materiality and texture of the surrounding environment



360°
Full-circle grazing light

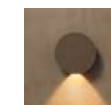

Direct
Directed grazing light



Mood Grazer
Tunable white or infinite colour regulation to curate the perfect atmosphere

Wall Washer



Vertical lighting to give structure and amplitude to a space. Diffuse light is reflected from the illuminated surface for a soft and homogeneous atmosphere

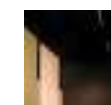

Linear
Bathing a vertical surface with light projected from a linear lighting application



Spot
Bathing a vertical surface with light projected from a spot lighting application

Direct

Spotlight



Adjustable, directed light for dynamic visual hierarchies, emphasising functional areas, objects or architectural elements



Accent
Narrow: Angles less than 20°. Suitable for generating high contrasts or projections at far distances.
Medium: Angles between 20° and 40°. Suitable for generating medium contrasts or projections at medium distances.
Wide: Angles greater than 40°. Suitable for generating moderate contrasts or projections at near distances.

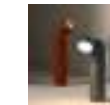

Reading
High intensity, glare-free task lighting

Downlight



Static, directed light for creating visual hierarchies and emphasising functional areas, objects or architectural elements



Accent
Narrow: Angles less than 20°. Suitable for generating high contrasts or projections at far distances.
Medium: Angles between 20° and 40°. Suitable for generating medium contrasts or projections at medium distances.
Wide: Angles greater than 40°. Suitable for generating moderate contrasts or projections at near distances.



Linear High Efficiency Low Glare



High energy efficiency and low glare levels UGR<19 for linear light applications

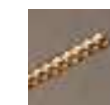

Support Portfolio



From Project Support to Usage

To achieve wellbeing scenes it is necessary to cover the entire end-to-end journey. From **design** and composition through to **installation** and **user interaction**, Vibia's team is prepared to assist you in any request you may have.

Sales Team Project Support

Direct contact with the Vibia representative in your area to assist you with whatever you need.

Selection of the appropriate product and customisation.

Creation of project moodboards by scenes.

Use of Vibia's online professional tools (Website, App, etc.).



Lighting & Wellbeing Studio

Vibia's specialised team is at your disposal to assist you in creating a complete Atmosphere Design project, including:

Scenes design.

Optional:

Lighting calculations, renderings, etc.

Control system approach.

End-user interaction approach.



Lighting Project Design with Scenes

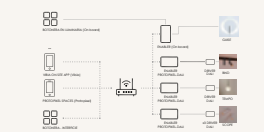

Control System and End-User Interaction Approach

Technical Support Services (TSS)

Our technical service team is available to assist you with any post-sales queries you may have, including:

Installation process.

Control System implementation process.

Maintenance.

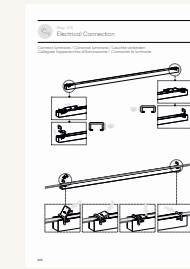

Installation and Maintenance Process

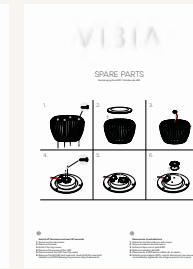

Control System Implementation

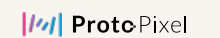

Online Professional Tools

Support for our digital tools designed for professionals.

Web: Professional Area.

Onsite App.



Web Project Management Area

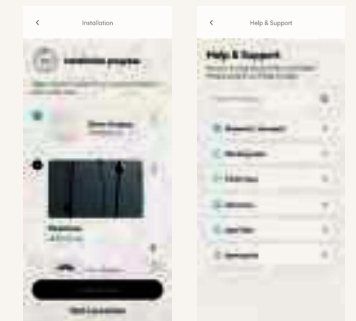

Onsite App

Atmosphere Design Content and Professional Training

Consult about Vibia's training program.

New Approach to Atmospheres Design:

Periodic online training sessions.

In-company training.

Certification Programs: COMING SOON.

Certificate in Emotional Atmosphere Design for project designers.

Certificate for Vibia Authorised Installers to provide local support.



Events for professionals

| Model | Vol Page | Model | Vol Page | Model | Vol Page | Model | Vol Page | Model | Vol Page | Model | Vol Page | Model | Vol Page | Model | Vol Page |
|-------|---------------------|-------|----------------|-------|-----------------|-------|---------------|-------|-----------------------|-------|-----------------------|-------|-----------------|-------|-----------------|
| 0130 | Vol 1 53 | 0825 | Vol 1 210 | 1747 | Vol 2 108 | 2340 | Vol 1 220 | 3510 | Vol 2 80 | 4078 | Vol 1 232 - Vol 2 428 | 4820 | Vol 2 421 | 5585 | Vol 1 362 |
| 0131 | Vol 1 53 | 0827 | Vol 1 210 | 1755 | Vol 2 104 | 2341 | Vol 1 220 | 3513 | Vol 2 80 | 4101 | Vol 2 432 | 4870 | Vol 2 11 | 5590 | Vol 1 362 |
| 0132 | Vol 1 53 | 0830 | Vol 1 210 | 1757 | Vol 2 104 | 2342 | Vol 1 220 | 3515 | Vol 2 80 | 4106 | Vol 2 432 | 4871 | Vol 2 17 | 5595 | Vol 1 362 |
| 0135 | Vol 2 59 | 0832 | Vol 1 210 | 1760 | Vol 2 112 - 353 | 2343 | Vol 1 220 | 3518 | Vol 2 80 | 4108 | Vol 2 432 | 4872 | Vol 2 11 | 5605 | Vol 1 416 |
| 0136 | Vol 2 59 | 0835 | Vol 1 210 | 1762 | Vol 2 112 - 353 | 2350 | Vol 1 226 | 3530 | Vol 2 84 | 4112 | Vol 2 443 | 4873 | Vol 2 17 | 5620 | Vol 1 416 |
| 0137 | Vol 2 59 | 0837 | Vol 1 210 | 1765 | Vol 2 112 - 353 | 2351 | Vol 1 226 | 3533 | Vol 2 84 | 4114 | Vol 2 443 | 4874 | Vol 2 11 | 5630 | Vol 2 333 |
| 0140 | Vol 1 53 - Vol 2 59 | 0840 | Vol 1 210 | 1767 | Vol 2 112 - 353 | 2355 | Vol 1 228 | 3535 | Vol 2 84 | 4116 | Vol 2 443 | 4875 | Vol 2 17 | 5660 | Vol 1 266 |
| 0141 | Vol 1 53 - Vol 2 59 | 0845 | Vol 1 210 | 1770 | Vol 2 352 | 2356 | Vol 1 228 | 3538 | Vol 2 84 | 4118 | Vol 2 443 | 4876 | Vol 2 11 | 5662 | Vol 1 266 |
| 0142 | Vol 1 53 - Vol 2 59 | 0847 | Vol 1 210 | 1772 | Vol 2 352 | 2360 | Vol 2 338 | 3540 | Vol 2 84 | 4125 | Vol 2 410 | 4877 | Vol 2 17 | 5664 | Vol 1 266 |
| 0151 | Vol 1 53 - Vol 2 59 | 0850 | Vol 1 210 | 1774 | Vol 2 352 | 2500 | Vol 1 164 | 3543 | Vol 2 84 | 4130 | Vol 2 410 | 4878 | Vol 2 11 | 5666 | Vol 1 416 |
| 0152 | Vol 1 53 - Vol 2 59 | 0860 | Vol 1 210 | 1780 | Vol 1 466 | 2501 | Vol 1 164 | 3550 | Vol 2 86 | 4135 | Vol 2 410 | 4879 | Vol 2 17 | 5670 | Vol 1 266 |
| 0153 | Vol 1 53 - Vol 2 59 | 0862 | Vol 1 210 | 1800 | Vol 1 12 | 2502 | Vol 1 164 | 3553 | Vol 2 86 | 4136 | Vol 2 410 | 4880 | Vol 2 11 | 5672 | Vol 1 266 |
| 0155 | Vol 1 52 - Vol 2 58 | 0865 | Vol 1 210 | 1805 | Vol 1 12 | 2510 | Vol 1 164 | 3555 | Vol 2 86 | 4270 | Vol 1 471 - Vol 2 387 | 4881 | Vol 2 17 | 5674 | Vol 1 266 |
| 0157 | Vol 1 52 - Vol 2 58 | 0867 | Vol 1 210 | 1810 | Vol 1 12 | 2511 | Vol 1 164 | 3558 | Vol 2 86 | 4275 | Vol 1 471 - Vol 2 387 | 4895 | Vol 1 452 | 5720 | Vol 1 377 |
| 0162 | Vol 1 52 - Vol 2 58 | 0870 | Vol 1 210 | 1815 | Vol 1 12 | 2515 | Vol 1 164 | 3560 | Vol 2 86 | 4440 | Vol 2 190 | 4896 | Vol 1 452 | 5725 | Vol 1 377 |
| 0164 | Vol 1 52 - Vol 2 58 | 0872 | Vol 1 210 | 1820 | Vol 1 12 | 2516 | Vol 1 164 | 3563 | Vol 2 86 | 4442 | Vol 2 190 | 4900 | Vol 1 452 | 5730 | Vol 1 18 |
| 0167 | Vol 1 52 - Vol 2 58 | 0875 | Vol 1 210 | 1825 | Vol 1 12 | 2600 | Vol 2 273 | 3565 | Vol 2 86 | 4452 | Vol 2 190 | 4901 | Vol 1 452 | 5756 | Vol 2 231 |
| 0171 | Vol 2 66 | 0877 | Vol 1 210 | 1830 | Vol 1 12 | 2602 | Vol 2 273 | 3568 | Vol 2 86 | 4454 | Vol 2 190 | 4905 | Vol 1 452 | 5757 | Vol 2 231 |
| 0172 | Vol 2 66 | 0920 | Vol 1 216 | 1835 | Vol 1 12 | 2610 | Vol 2 273 | 3575 | Vol 2 88 | 4460 | Vol 2 190 | 4906 | Vol 1 452 | 5758 | Vol 2 231 |
| 0173 | Vol 2 66 | 1154 | Vol 2 215 | 1840 | Vol 1 12 | 2612 | Vol 2 273 | 3578 | Vol 2 88 | 4500 | Vol 2 315 - 392 | 4925 | Vol 1 125 | 5759 | Vol 2 231 |
| 0176 | Vol 1 64 | 1155 | Vol 2 215 | 1845 | Vol 1 12 | 2615 | Vol 2 273 | 3580 | Vol 2 88 | 4501 | Vol 2 315 - 392 | 4926 | Vol 1 125 | 5760 | Vol 2 231 |
| 0177 | Vol 1 64 | 1160 | Vol 2 41 - 215 | 1850 | Vol 1 13 | 2617 | Vol 2 273 | 3583 | Vol 2 88 | 4504 | Vol 2 315 - 392 | 4960 | Vol 1 442 | 5761 | Vol 2 231 |
| 0178 | Vol 1 64 | 1170 | Vol 2 41 - 215 | 1855 | Vol 1 13 | 2630 | Vol 2 180 | 3585 | Vol 2 88 | 4506 | Vol 2 315 - 392 | 4965 | Vol 1 442 | 5762 | Vol 2 231 |
| 0182 | Vol 1 62 | 1510 | Vol 1 158 | 1860 | Vol 1 13 | 2632 | Vol 2 180 | 3588 | Vol 2 88 | 4508 | Vol 2 315 - 392 | 4970 | Vol 1 442 | 5763 | Vol 2 231 |
| 0185 | Vol 1 62 | 1527 | Vol 1 158 | 1865 | Vol 1 13 | 2634 | Vol 2 180 | 3605 | Vol 2 90 | 4510 | Vol 2 400 | 4987 | Vol 1 92 | 5764 | Vol 2 231 |
| 0187 | Vol 1 62 | 1530 | Vol 1 158 | 1870 | Vol 1 13 | 2640 | Vol 2 180 | 3608 | Vol 2 90 | 4516 | Vol 2 400 | 5189 | Vol 1 402 | 5765 | Vol 2 231 |
| 0193 | Vol 1 63 | 1540 | Vol 1 159 | 1875 | Vol 1 13 | 2642 | Vol 2 180 | 3610 | Vol 2 90 | 4539 | Vol 2 400 | 5190 | Vol 1 402 | 5766 | Vol 2 231 |
| 0196 | Vol 1 63 | 1550 | Vol 1 159 | 1880 | Vol 1 13 | 2645 | Vol 2 180 | 3613 | Vol 2 90 | 4540 | Vol 2 400 | 5191 | Vol 1 402 | 5767 | Vol 2 231 |
| 0260 | Vol 1 436 | 1560 | Vol 1 159 | 2012 | Vol 2 174 - 302 | 2647 | Vol 2 180 | 3700 | Vol 2 260 | 4625 | Vol 2 406 | 5192 | Vol 1 402 | 5770 | Vol 1 238 |
| 0270 | Vol 1 120 | 1570 | Vol 1 159 | 2013 | Vol 2 174 - 302 | 2800 | Vol 2 466 | 3702 | Vol 2 260 | 4630 | Vol 2 406 | 5410 | Vol 2 195 - 322 | 5772 | Vol 1 238 |
| 0275 | Vol 1 120 | 1575 | Vol 1 150 | 2014 | Vol 2 174 | 2805 | Vol 2 466 | 3704 | Vol 2 260 | 4635 | Vol 2 406 | 5412 | Vol 2 195 - 322 | 5774 | Vol 1 238 |
| 0299 | Vol 1 129 | 1580 | Vol 1 150 | 2110 | Vol 1 186 | 2810 | Vol 2 466 | 3706 | Vol 2 260 | 4640 | Vol 2 406 | 5425 | Vol 2 322 | 5776 | Vol 1 238 |
| 0300 | Vol 1 129 | 1585 | Vol 1 150 | 2111 | Vol 1 186 | 2815 | Vol 2 466 | 3710 | Vol 2 260 | 4660 | Vol 2 251 | 5427 | Vol 2 322 | 5778 | Vol 1 238 |
| 0301 | Vol 1 129 | 1590 | Vol 1 150 | 2112 | Vol 1 186 | 2820 | Vol 2 466 | 3714 | Vol 2 260 | 4662 | Vol 2 251 | 5430 | Vol 2 195 | 5780 | Vol 1 238 |
| 0302 | Vol 1 129 | 1650 | Vol 1 423 | 2113 | Vol 1 186 | 2825 | Vol 2 466 | 3716 | Vol 2 260 | 4665 | Vol 2 251 | 5432 | Vol 2 195 | 5905 | Vol 2 74 |
| 0303 | Vol 1 129 | 1655 | Vol 1 423 | 2120 | Vol 1 186 | 3225 | Vol 1 370 | 3718 | Vol 2 260 | 4670 | Vol 2 251 | 5435 | Vol 2 195 | 5910 | Vol 2 74 |
| 0309 | Vol 1 129 | 1660 | Vol 1 423 | 2121 | Vol 1 186 | 3230 | Vol 1 370 | 3720 | Vol 1 172 | 4675 | Vol 2 251 | 5437 | Vol 2 195 | 5915 | Vol 2 74 |
| 0310 | Vol 1 129 | 1670 | Vol 1 423 | 2122 | Vol 1 186 | 3235 | Vol 1 24 | 3724 | Vol 1 172 | 4680 | Vol 2 255 - 376 | 5470 | Vol 2 327 | 5920 | Vol 2 74 |
| 0311 | Vol 1 129 | 1675 | Vol 2 266 | 2141 | Vol 1 193 | 3300 | Vol 2 24 - 28 | 3726 | Vol 1 172 | 4684 | Vol 2 370 | 5471 | Vol 2 327 | 5922 | Vol 2 74 |
| 0312 | Vol 1 129 | 1680 | Vol 2 266 | 2142 | Vol 1 193 | 3303 | Vol 2 24 - 28 | 3728 | Vol 1 172 | 4688 | Vol 2 370 | 5472 | Vol 2 327 | 5924 | Vol 2 74 |
| 0315 | Vol 1 142 | 1685 | Vol 2 266 | 2143 | Vol 1 193 | 3306 | Vol 2 24 - 28 | 3730 | Vol 1 172 | 4695 | Vol 2 370 | 5474 | Vol 2 327 | 5926 | Vol 2 74 |
| 0320 | Vol 1 132 | 1686 | Vol 2 266 | 2155 | Vol 1 184 | 3310 | Vol 2 24 - 28 | 3734 | Vol 1 174 | 4697 | Vol 2 370 | 5476 | Vol 2 327 | 5930 | Vol 1 98 |
| 0325 | Vol 1 132 | 1690 | Vol 2 266 | 2165 | Vol 1 190 | 3313 | Vol 2 24 - 28 | 3736 | Vol 1 174 | 4700 | Vol 2 370 | 5480 | Vol 2 327 | 5935 | Vol 1 98 |
| 0330 | Vol 1 132 | 1692 | Vol 2 266 | 2167 | Vol 1 190 | 3316 | Vol 2 24 - 28 | 3760 | Vol 2 118 | 4702 | Vol 2 370 | 5481 | Vol 2 327 | 5940 | Vol 1 98 |
| 0338 | Vol 1 132 | 1694 | Vol 2 266 | 2260 | Vol 2 292 | 3320 | Vol 2 24 - 28 | 3764 | Vol 2 118 | 4710 | Vol 2 452 | 5485 | Vol 2 327 | 5945 | Vol 1 410 |
| 0347 | Vol 1 138 | 1720 | Vol 2 98 | 2262 | Vol 2 292 | 3323 | Vol 2 24 - 28 | 3900 | Vol 2 204 | 4715 | Vol 2 452 | 5486 | Vol 2 327 | 5950 | Vol 1 410 |
| 0348 | Vol 1 138 | 1722 | Vol 2 98 | 2263 | Vol 2 292 | 3326 | Vol 2 24 - 28 | 3905 | Vol 2 204 | 4720 | Vol 2 452 | 5487 | Vol 2 327 | 5955 | Vol 1 410 |
| 0361 | Vol 1 138 | 1725 | Vol 2 98 | 2270 | Vol 1 115 | 3330 | Vol 2 24 - 28 | 3910 | Vol 2 204 | 4780 | Vol 2 448 | 5491 | Vol 2 327 | 5957 | Vol 1 410 |
| 0374 | Vol 1 143 | 1727 | Vol 2 98 | 2272 | Vol 1 115 | 3333 | Vol 2 24 - 28 | 3915 | Vol 2 204 | 4785 | Vol 2 448 | 5495 | Vol 1 392 | 5965 | Vol 1 410 |
| 0375 | Vol 1 143 | 1728 | Vol 2 102 | 2277 | Vol 1 115 | 3336 | Vol 2 24 - 28 | 3920 | Vol 1 180 | 4800 | Vol 2 421 | 5496 | Vol 1 392 | 5970 | Vol 1 410 |
| 0376 | Vol 1 142 | 1729 | Vol 2 108 | 2282 | Vol 1 114 | 3350 | Vol 2 32 | 3925 | Vol 1 180 | 4801 | Vol 2 421 | 5497 | Vol 1 392 | 5972 | Vol 1 410 |
| 0377 | Vol 1 142 | 1730 | Vol 2 102 | 2288 | Vol 1 114 | 3353 | Vol 2 32 | 3930 | Vol 1 180 | 4802 | Vol 2 421 | 5500 | Vol 1 399 | 5975 | Vol 2 186 - 240 |
| 0378 | Vol 1 143 | 1732 | Vol 2 108 | 2292 | Vol 2 171 | 3360 | Vol 2 34 | 3935 | Vol 1 180 | 4803 | Vol 2 421 | 5505 | Vol 1 399 | 5977 | Vol 2 186 - 240 |
| 0700 | Vol 1 429 | 1735 | Vol 2 102 | 2298 | Vol 2 171 | 3363 | Vol 2 34 | 4057 | Vol 2 428 | 4804 | Vol 2 420 | 5510 | Vol 1 399 | 5979 | Vol 2 186 - 240 |
| 0712 | Vol 1 429 | 1737 | Vol 2 108 | 2330 | Vol 1 222 | 3500 | Vol 2 80 | 4062 | Vol 2 428 | 4805 | Vol 2 420 | 5515 | Vol 1 399 | 5981 | Vol 2 187 - 240 |
| 0720 | Vol 2 311 | 1740 | Vol 2 102 | 2331 | Vol 1 222 | 3503 | Vol 2 80 | 4067 | Vol 2 428 | 4810 | Vol 2 420 | 5520 | Vol 1 198 | 5983 | Vol 2 187 - 240 |
| 0721 | Vol 2 311 | 1742 | Vol 2 108 | 2332 | Vol 1 222 | 3505 | Vol 2 80 | 4072 | Vol 1 232 - Vol 2 428 | 4811 | Vol 2 420 | 5525 | Vol 1 198 | 5985 | Vol 2 187 - 240 |
| 0820 | Vol 1 204 | 1745 | Vol 2 102 | 2333 | Vol 1 222 | 3508 | Vol 2 80 | 4077 | Vol 1 232 - Vol 2 428 | 4812 | Vol 2 420 | 5580 | Vol 1 362 | 5987 | Vol 2 241 |

| Model | Vol | Page | Model | Vol | Page | Model | Vol | Page | Model | Vol | Page |
|-------|-------|-----------------|-------|-------|-----------------|-------|-------|---------------|-------|-------|------|
| 5989 | Vol 2 | 241 | 6474 | Vol 1 | 88 | 7310 | Vol 1 | 72 | A361 | Vol 1 | 50 |
| 5991 | Vol 2 | 241 | 6476 | Vol 1 | 88 | 7313 | Vol 1 | 72 | A362 | Vol 1 | 50 |
| 5993 | Vol 2 | 241 | 6500 | Vol 1 | 259 - Vol 2 143 | 7316 | Vol 1 | 72 | A363 | Vol 1 | 50 |
| 5995 | Vol 2 | 241 | 6504 | Vol 1 | 259 - Vol 2 143 | 7320 | Vol 1 | 73 | A364 | Vol 1 | 50 |
| 6006 | Vol 1 | 433 | 6510 | Vol 1 | 259 - Vol 2 143 | 7323 | Vol 1 | 73 | A365 | Vol 1 | 50 |
| 6007 | Vol 1 | 433 | 6514 | Vol 1 | 259 - Vol 2 143 | 7326 | Vol 1 | 73 | A366 | Vol 1 | 50 |
| 6011 | Vol 1 | 433 | 6520 | Vol 1 | 259 - Vol 2 143 | 7338 | Vol 1 | 387 | A367 | Vol 1 | 50 |
| 6012 | Vol 1 | 433 | 6524 | Vol 1 | 259 - Vol 2 143 | 7339 | Vol 1 | 387 | A368 | Vol 1 | 50 |
| 6040 | Vol 2 | 306 | 6525 | Vol 1 | 259 - Vol 2 143 | 7348 | Vol 1 | 387 | A369 | Vol 1 | 50 |
| 6041 | Vol 2 | 306 | 6528 | Vol 1 | 259 - Vol 2 143 | 7350 | Vol 1 | 73 | A370 | Vol 1 | 50 |
| 6045 | Vol 2 | 306 | 6529 | Vol 1 | 259 - Vol 2 143 | 7353 | Vol 1 | 73 | A371 | Vol 1 | 50 |
| 6046 | Vol 2 | 306 | 6530 | Vol 1 | 259 - Vol 2 143 | 7356 | Vol 1 | 73 | A372 | Vol 1 | 50 |
| 6095 | Vol 2 | 200 | 6534 | Vol 1 | 259 - Vol 2 143 | 7360 | Vol 1 | 78 | A373 | Vol 1 | 50 |
| 6100 | Vol 2 | 200 | 6538 | Vol 1 | 259 - Vol 2 143 | 7361 | Vol 1 | 78 | A374 | Vol 1 | 50 |
| 6105 | Vol 2 | 200 | 6540 | Vol 1 | 258 - Vol 2 145 | 7363 | Vol 1 | 78 | A375 | Vol 1 | 50 |
| 6160 | Vol 1 | 104 | 6542 | Vol 1 | 258 - Vol 2 145 | 7364 | Vol 1 | 78 | A376 | Vol 1 | 50 |
| 6165 | Vol 1 | 104 | 6560 | Vol 1 | 263 - Vol 2 147 | 7365 | Vol 1 | 78 | A377 | Vol 1 | 50 |
| 6200 | Vol 1 | 346 | 6561 | Vol 1 | 263 - Vol 2 147 | 7366 | Vol 1 | 78 | A378 | Vol 1 | 50 |
| 6205 | Vol 1 | 346 | 6570 | Vol 1 | 263 - Vol 2 147 | 7368 | Vol 1 | 78 | A379 | Vol 1 | 50 |
| 6210 | Vol 1 | 346 | 6571 | Vol 1 | 263 - Vol 2 147 | 7369 | Vol 1 | 78 | A380 | Vol 1 | 50 |
| 6215 | Vol 1 | 346 | 6575 | Vol 1 | 262 - Vol 2 146 | 7375 | Vol 1 | 387 | A381 | Vol 1 | 50 |
| 6220 | Vol 1 | 346 | 6576 | Vol 1 | 262 - Vol 2 146 | 7376 | Vol 1 | 387 | A382 | Vol 1 | 50 |
| 6225 | Vol 1 | 346 | 6580 | Vol 1 | 263 - Vol 2 147 | 7378 | Vol 1 | 387 | A383 | Vol 1 | 50 |
| 6230 | Vol 1 | 346 | 6581 | Vol 1 | 263 - Vol 2 147 | 7379 | Vol 1 | 387 | A384 | Vol 1 | 50 |
| 6235 | Vol 1 | 346 | 6583 | Vol 1 | 263 - Vol 2 147 | 7400 | Vol 1 | 458 | A385 | Vol 1 | 50 |
| 6240 | Vol 1 | 346 | 6584 | Vol 1 | 263 - Vol 2 147 | 7402 | Vol 1 | 458 | A386 | Vol 1 | 50 |
| 6245 | Vol 1 | 346 | 6586 | Vol 1 | 263 - Vol 2 147 | 7404 | Vol 1 | 458 | A387 | Vol 1 | 50 |
| 6250 | Vol 1 | 347 | 6587 | Vol 1 | 263 - Vol 2 147 | 7415 | Vol 2 | 298 | A388 | Vol 1 | 50 |
| 6255 | Vol 1 | 347 | 6590 | Vol 1 | 262 - Vol 2 146 | 7450 | Vol 1 | 31 | A389 | Vol 1 | 50 |
| 6260 | Vol 1 | 347 | 6591 | Vol 1 | 262 - Vol 2 146 | 7455 | Vol 1 | 31 | A390 | Vol 1 | 50 |
| 6265 | Vol 1 | 347 | 6600 | Vol 2 | 152 | 7460 | Vol 1 | 31 | A391 | Vol 1 | 50 |
| 6270 | Vol 1 | 347 | 6604 | Vol 2 | 152 | 7470 | Vol 1 | 31 | A392 | Vol 1 | 50 |
| 6275 | Vol 1 | 347 | 6610 | Vol 2 | 156 | 7475 | Vol 1 | 31 | A393 | Vol 1 | 50 |
| 6280 | Vol 1 | 347 | 6614 | Vol 2 | 156 | 7480 | Vol 1 | 382 | A414 | Vol 2 | 140 |
| 6285 | Vol 1 | 347 | 6620 | Vol 2 | 160 | 7485 | Vol 1 | 382 | A415 | Vol 2 | 140 |
| 6330 | Vol 2 | 126 - 224 | 6624 | Vol 2 | 160 | 7487 | Vol 1 | 382 | A416 | Vol 2 | 140 |
| 6331 | Vol 2 | 126 - 224 | 6630 | Vol 2 | 156 | 7490 | Vol 1 | 382 | A417 | Vol 1 | 260 |
| 6332 | Vol 2 | 126 - 224 | 6634 | Vol 2 | 156 | 7492 | Vol 1 | 382 | A418 | Vol 1 | 260 |
| 6333 | Vol 2 | 126 - 224 | 6640 | Vol 2 | 160 | 7494 | Vol 1 | 382 | A419 | Vol 1 | 260 |
| 6335 | Vol 2 | 126 - 224 | 6644 | Vol 2 | 160 | 7749 | Vol 2 | 276 | A420 | Vol 1 | 260 |
| 6340 | Vol 2 | 126 - 224 | 6650 | Vol 2 | 152 | 7750 | Vol 2 | 276 | A421 | Vol 1 | 260 |
| 6341 | Vol 1 | 480 | 6654 | Vol 2 | 152 | 7751 | Vol 2 | 276 | A422 | Vol 1 | 260 |
| 6343 | Vol 1 | 480 | 6658 | Vol 2 | 152 | 7752 | Vol 2 | 276 | A423 | Vol 1 | 260 |
| 6346 | Vol 1 | 480 | 6660 | Vol 2 | 156 | 7753 | Vol 2 | 276 | A424 | Vol 1 | 260 |
| 6348 | Vol 1 | 480 | 6664 | Vol 2 | 156 | 7940 | Vol 2 | 318 | A425 | Vol 1 | 260 |
| 6361 | Vol 1 | 480 - Vol 2 224 | 6668 | Vol 2 | 156 | 7942 | Vol 2 | 318 | A439 | Vol 1 | 362 |
| 6363 | Vol 1 | 480 - Vol 2 224 | 6670 | Vol 2 | 160 | A146 | Vol 1 | 54 - Vol 2 60 | A440 | Vol 1 | 362 |
| 6365 | Vol 1 | 480 - Vol 2 224 | 6674 | Vol 2 | 160 | A147 | Vol 1 | 54 - Vol 2 60 | A491 | Vol 2 | 140 |
| 6370 | Vol 1 | 480 - Vol 2 224 | 6678 | Vol 2 | 160 | A352 | Vol 1 | 50 - Vol 2 56 | A492 | Vol 2 | 140 |
| 6414 | Vol 2 | 287 | 6680 | Vol 2 | 156 | A353 | Vol 1 | 50 - Vol 2 56 | A493 | Vol 2 | 140 |
| 6416 | Vol 2 | 287 | 6684 | Vol 2 | 156 | A354 | Vol 1 | 50 - Vol 2 56 | Match | Vol 1 | 168 |
| 6418 | Vol 2 | 287 | 6688 | Vol 2 | 156 | A355 | Vol 1 | 50 - Vol 2 56 | | | |
| 6434 | Vol 1 | 84 | 6690 | Vol 2 | 160 | A356 | Vol 1 | 50 - Vol 2 56 | | | |
| 6436 | Vol 1 | 84 | 6694 | Vol 2 | 160 | A357 | Vol 1 | 50 - Vol 2 56 | | | |
| 6438 | Vol 1 | 84 | 6698 | Vol 2 | 160 | A358 | Vol 1 | 50 | | | |
| 6444 | Vol 2 | 283 | 6700 | Vol 2 | 166 | A359 | Vol 1 | 50 | | | |
| 6446 | Vol 2 | 283 | 6702 | Vol 2 | 166 | A360 | Vol 1 | 50 | | | |

Photography: © David Zarzoso
(Page 7)

Architecture: Objekt Architekten
(Page 15)

Photography: José Hevia
(Page 21)

Photography: Ypsilon Business
Architecture: Objekt Architekten
(Page 22)

Photography: © David Zarzoso
(Page 30)

CO Arquitectura and Altointeriorismo
(Page 31)

Photography: Jesús Granada
(Page 35)

Architecture: Marià Castelló
@mcastello_arch
(Page 37, 38, 75, 157, 222, 313, 375, 377, 390,
391, 419, 426 and 444)

Photography: @fotografadearquitectura
Architecture: DG Estudio
@dg_arquitecto_estudio
@at4_grupo
@m_madentia
@schottenwood
@mobalco.vlc
(Page 47)

Photography: @fotografadearquitectura
Architecture: studioLucus
@studio_lucus
Francés Construcciones
@frances.construcciones
(Page 48)

Photography: @fotografadearquitectura
Architecture: R21 Arkitekter
@r21arkitekter
Constructor Saulius Balsevicius
@gravitas_bygg_as
(Page 49)

Architecture: César Béjar
(Page 52)

Photography: @fotografadearquitectura
Architect: Andrea Pons
@andreaponsarquitectura
(Page 53)

Zentrum la Garriga
(Page 117)

CO Arquitectura and Altointeriorismo
(Page 122)

Photography: Fernando Alda
Architecture: Inmaculada González,
Harald Schönegger
Project: Private house in Seville.
(Page 125)

Project: Pugets
Architecture: Lorenzo Zandri © 2021
@lorenzozandri Bancau Architectes
(Page 131)

Photography: @fotografadearquitectura
Architecture: Ramón Esteve Estudio
(Page 132)

Photography: Perry Cheung
Project: Francesc Rifé
(Page 135)

Photography: Alejandra Urquiza
(Page 137)

Photography: Marc Tey
(Page 166)

Photography: Fernando Guerra
http://ultimasreportagens.com
(Page 169)

Photography: João Fôja & Eduardo Nascimento
Do mal o menos
www.domalomenos.com
(Page 175)

Photography: Joe Fletcher
Architecture: Garcia Tamjidi
(Page 178)

CO Arquitectura and Altointeriorismo
(Page 199)

Photography: Jesús Granada
(Page 207)

Photography: Raúl Candaes
Project: VIVE ESTUDIO
(Page 219 and 351)

Photography: Luis Díaz
(Page 221)

Project: Neiheiser Argyros: Grid House
Architecture: Lorenzo Zandri © 2021
@lorenzozandri
(Page 223)

Photography: Jeremy Bittermann / JBSA
Interior designer: Nils Van der Celen
(Page 247)

Photography: Fernando Alda
Architects: Donaire Barbero, Juan Pedro,
Isabel López Vilalta, Sandra Tarruella
(Page 249)

Photography: Aleix Bagué
(Page 254)

@M114
@cotlin.barcelona
nanimarquina.com (Page 279)

Artwork @Claudia Valsells
courtesy of @Alzueta_Gallery
(Page 284)

Photography: Sandra Rojo
Architecture: Thisispaper Studio
(Page 284)

Zentrum la Garriga
(Page 308)

Photography: Ricardo Gonçalves
Architecture: Aboim Inglez Arquitectos
(Page 328)

Architect: Cristina Soler from Arquemo
Photography: Enric Badrinás
(Page 332 and 335)

MR.P Studios
(Page 343)

Bernadí Hub
www.bernadi.es
(Page 367)

Fieldwork Design
Photography: Jeremy Bittermann / JBSA
(Page 368 and 460)

Photographer: Ricardo Gonçalves
www.ricardogoncalves.pt
Architecture: Aboim Inglez Arquitectos
(Page 389)

Nacho Carbó
Photography: Mariela Apollonio
(Page 434)

Architecture: Ideo Arquitectura
Photography: Salva López
(Page 439)

Unterlandstättner Architekten
www.u-architekten.de
Photography: Michael Heinrich
(Page 459)

Vibia Lighting, S.L.U.

Spain & Portugal T. +34 934 796 970

International T. +34 934 796 971

hello@vibia.com

www.vibia.com

Shaping Atmospheres

We put people at the centre of everything we do; we aim to improve lives by helping professionals create better spaces for everyone to enjoy. This purpose is shared across the entire space-design ecosystem.

We aim to lead a new approach to lighting, focused on people's emotions, elevating interior design as a fundamental discipline for the cultivation of wellbeing.

vibia.com